

LOC		DIST		REVISIONS			
GP	00	P	LTN	DESCRIPTION	DATE	OWN	APVD
		C		REVISED PER ECO-15-017922	11APR2015	AP	RP
		D		REVISED PER ECO-17-018458	18DEC2017	IT	SH

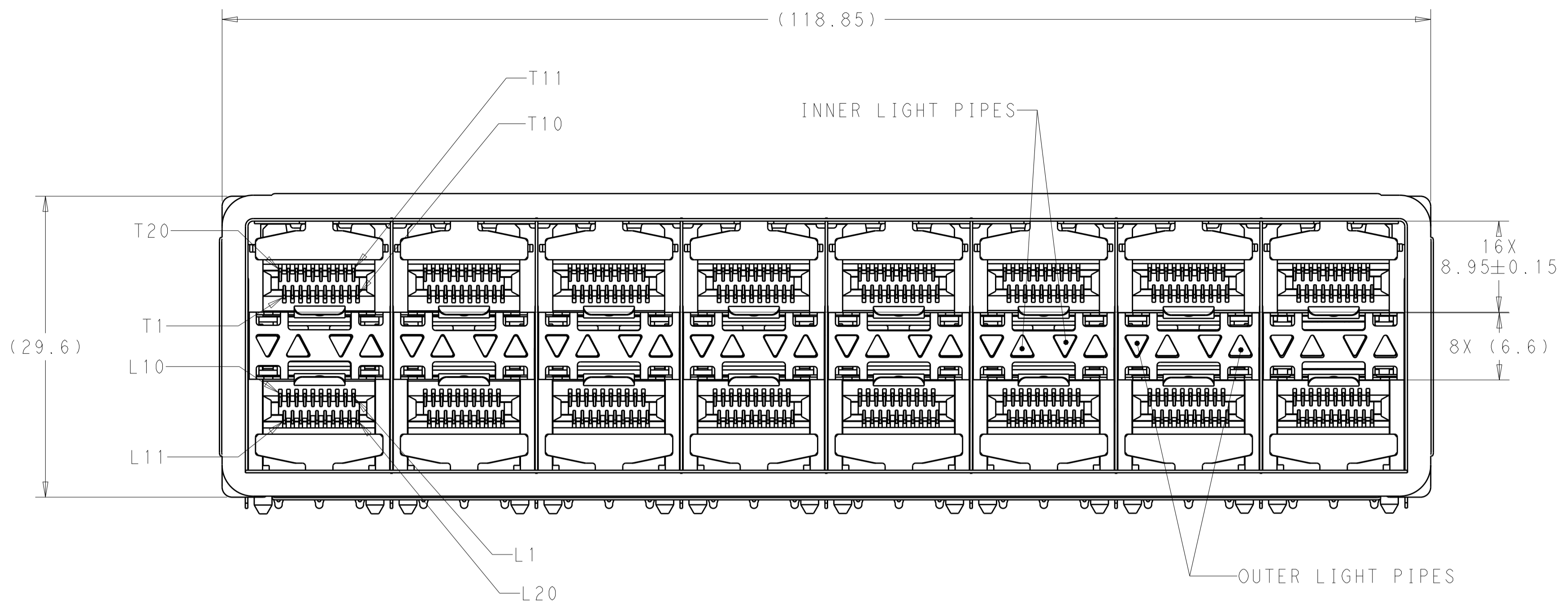

2169788-5 AS SHOWN

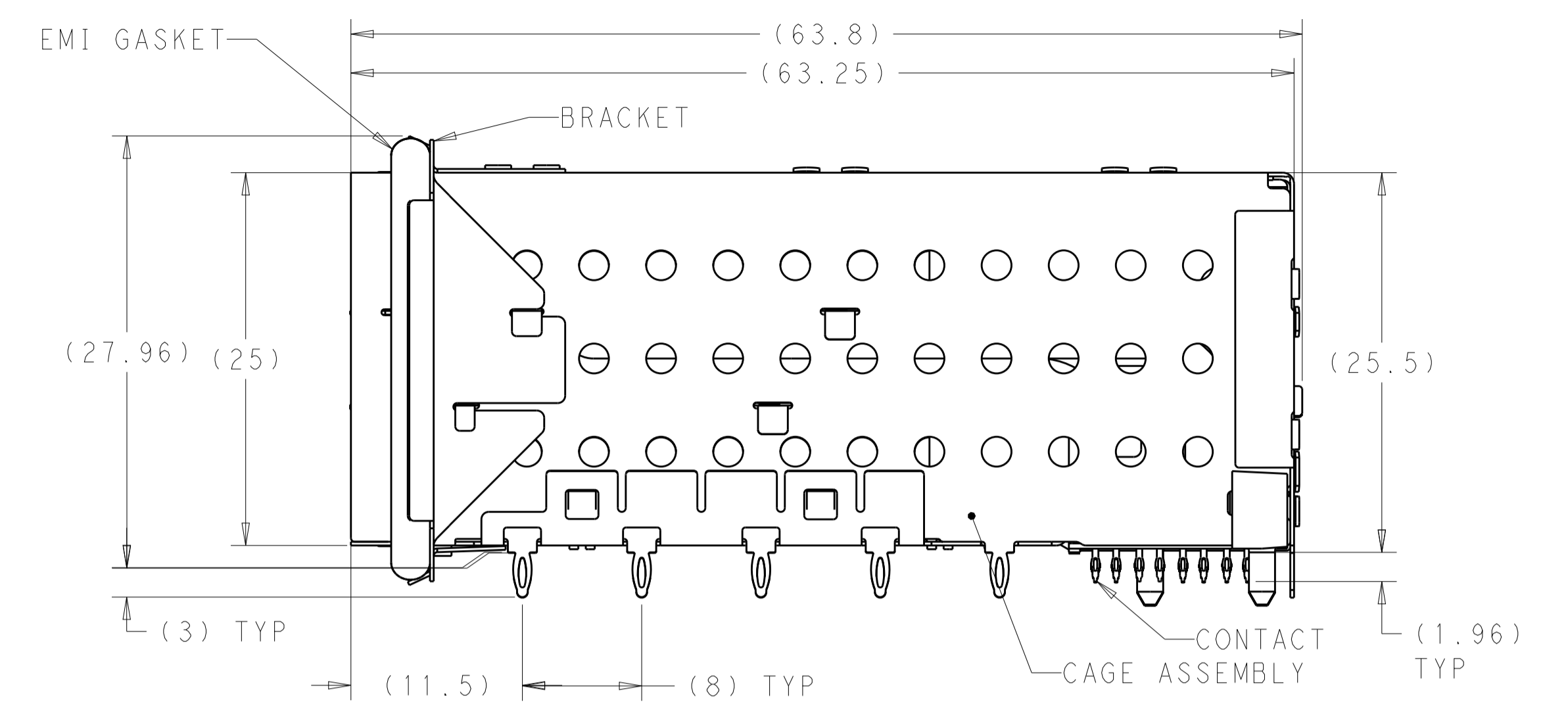
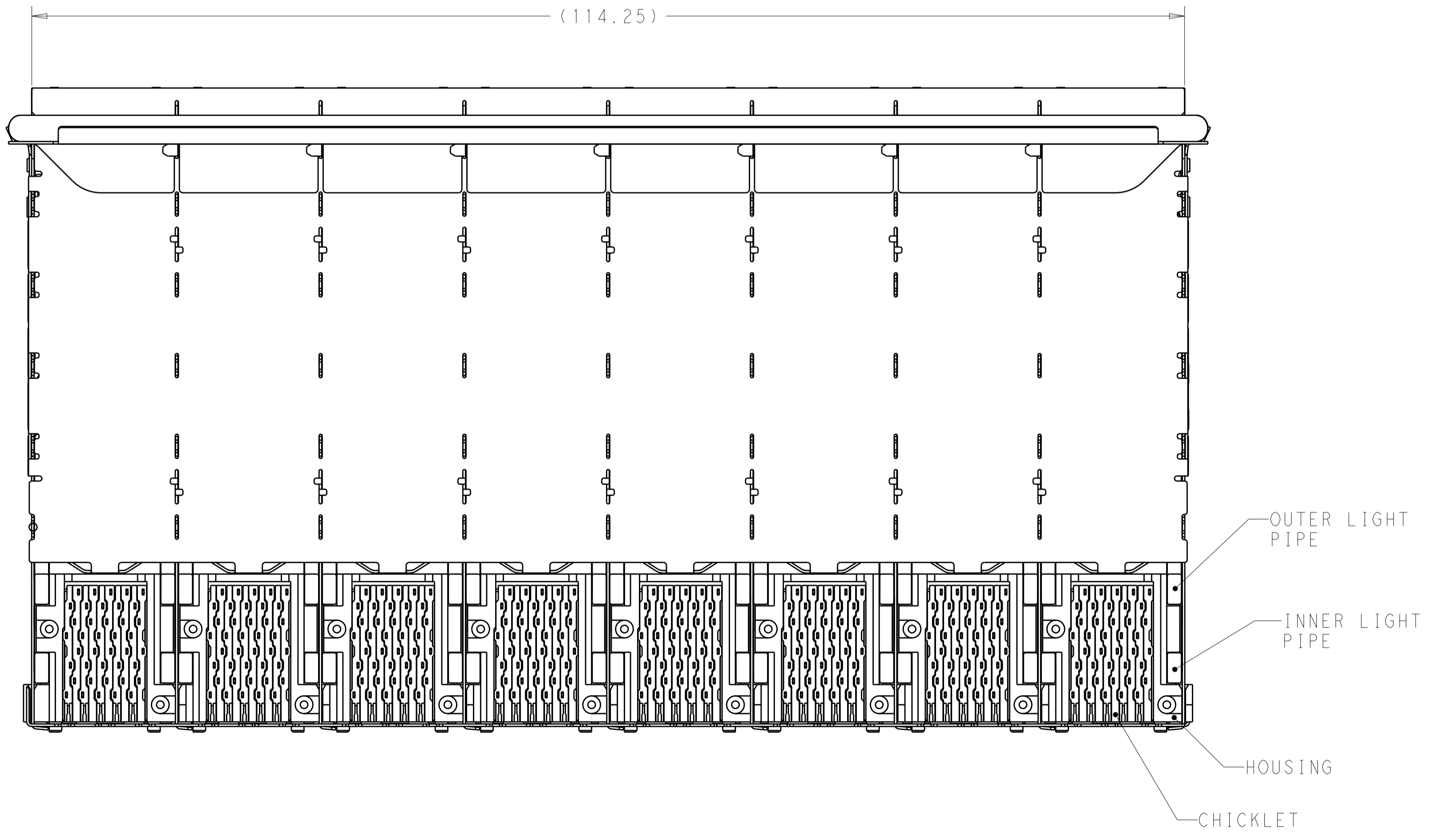

- 1 MATERIALS:  
 CAGE ASSEMBLY- NICKEL SILVER ALLOY PER ASTM B 122.  
 BRACKET- STAINLESS STEEL.  
 EMI GASKET- PLATED FILLED SILICONE.  
 HOUSING- BLACK LCP, UL 94V-0 RATED.  
 CHICKLET- BLACK LCP, UL 94V-0 RATED.  
 LIGHT PIPE- POLYCARBONATE, CLEAR.  
 CONTACT- COPPER ALLOY.
- 2 DATUM AND BASIC DIMENSIONS ESTABLISHED BY CUSTOMER.
- 3. MINIMUM PCB THICKNESS OF 1.5.
- 4 CONTACT FINISH- CONFORMS TO THE REQUIREMENTS OF TE PRODUCT SPECIFICATION 108-2331, BASED ON EIA/ECA-364-1000.01A, (CONTROLLED ENVIRONMENT APPLICATIONS) ON MATING INTERFACE, TIN-LEAD ON NEEDLE EYE.
- 5 CONTACT FINISH- CONFORMS TO THE REQUIREMENTS OF TE PRODUCT SPECIFICATION 108-2331, BASED ON EIA/ECA-364-1000.01A, (CONTROLLED ENVIRONMENT APPLICATIONS) ON MATING INTERFACE, TIN ON NEEDLE EYE.
- 6 FOR HOLE SIZE AND PLATINGS, SEE APPLICATION SPEC 114-13219.
- 7 THE ENTIRE AREA OF THE CONNECTOR FOOTPRINT, INDICATED BY THE DASHED LINE, TO BE CONSIDERED THE KEEPOUT AREA FOR COMPONENTS AND SIGNAL TRACES, TOP SIDE ONLY. TOP SIDE TRACES ALLOWED WITHIN CONNECTOR HOLE PATTERN.
- 8 LIGHT PIPE PAD LAYOUT IS FOR 0805 LOW PROFILE LED PACKAGE WITH A HEIGHT OF 0.8mm.
- 9 ADDITIONAL COMPONENT LOCATED WITHIN LATCHPLATE FOR EMI SUPPRESSION

YES 9	5	NO LIGHT PIPES	1-2169788-8
		OUTER 2 LIGHT PIPES	1-2169788-7
		INNER 2 LIGHT PIPES	1-2169788-6
		4 LIGHT PIPES	1-2169788-5
		NO LIGHT PIPES	2169788-8
	5	OUTER 2 LIGHT PIPES	2169788-7
		INNER 2 LIGHT PIPES	2169788-6
		4 LIGHT PIPES	2169788-5
		NO LIGHT PIPES	2169788-4
		OUTER 2 LIGHT PIPES	2169788-3
		INNER 2 LIGHT PIPES	2169788-2
		4 LIGHT PIPES	2169788-1
ENHANCED EMI FINISH	DESCRIPTION	PART NUMBER	

THIS DRAWING IS A CONTROLLED DOCUMENT. DWN: C. VALENTINE 18JAN2011  
 CHK: P. RECCE 18JAN2011  
 APVD: P. RECCE 18JAN2011

**STE** TE Connectivity

NAME: CAGE AND PT CONNECTOR ASSEMBLY, WITH EMI GASKET, PRESS FIT, 2X8, STACKED SFP+

PRODUCT SPEC: 108-2331  
 APPLICATION SPEC: 114-13219

SIZE: CAGE CODE DRAWING NO: A100779C=2169788  
 RESTRICTED TO: -

MATERIAL: SEE TABLE  
 FINISH: SEE TABLE  
 WEIGHT: -  
 CUSTOMER DRAWING

SCALE: 3:1 SHEET 1 OF 4 REV D

LOC		DIST		REVISIONS			
GP	00	P	LYN	DESCRIPTION	DATE	OWN	APVD
				SEE SHEET 1			

2169788-5 AND 1-2169788-5

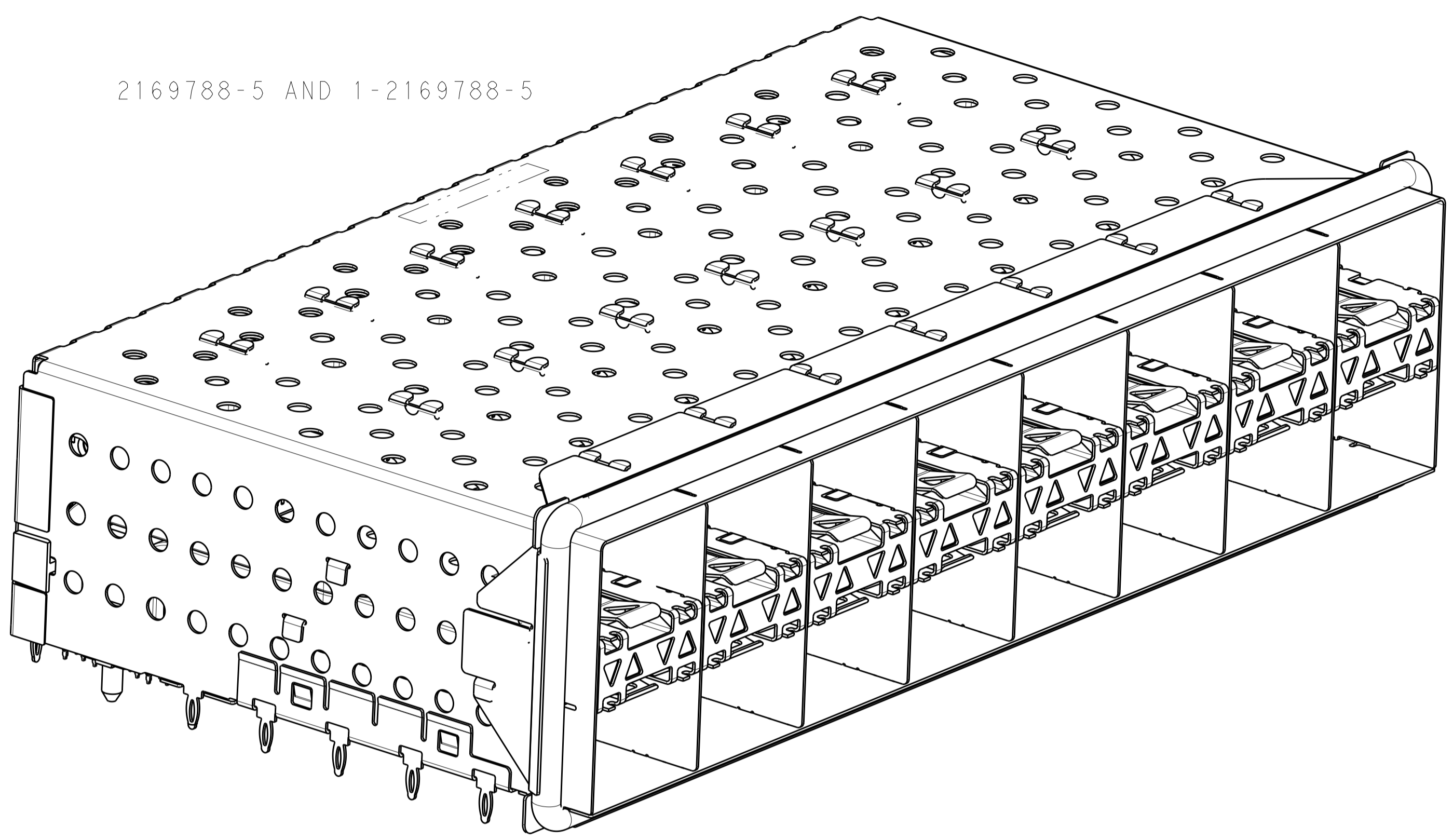

2169788-6 AND 1-2169788-6

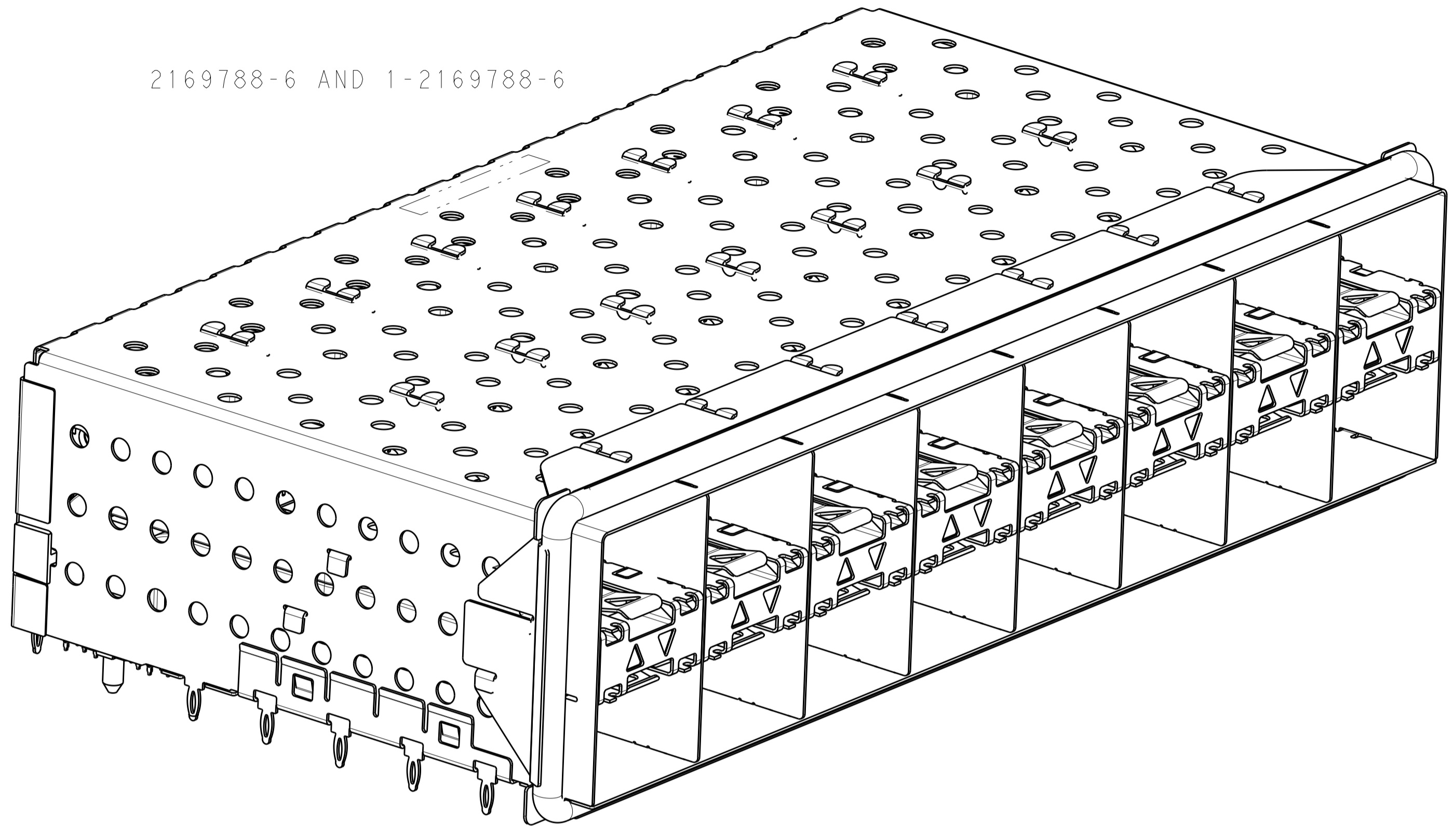

2169788-7 AND 1-2169788-7

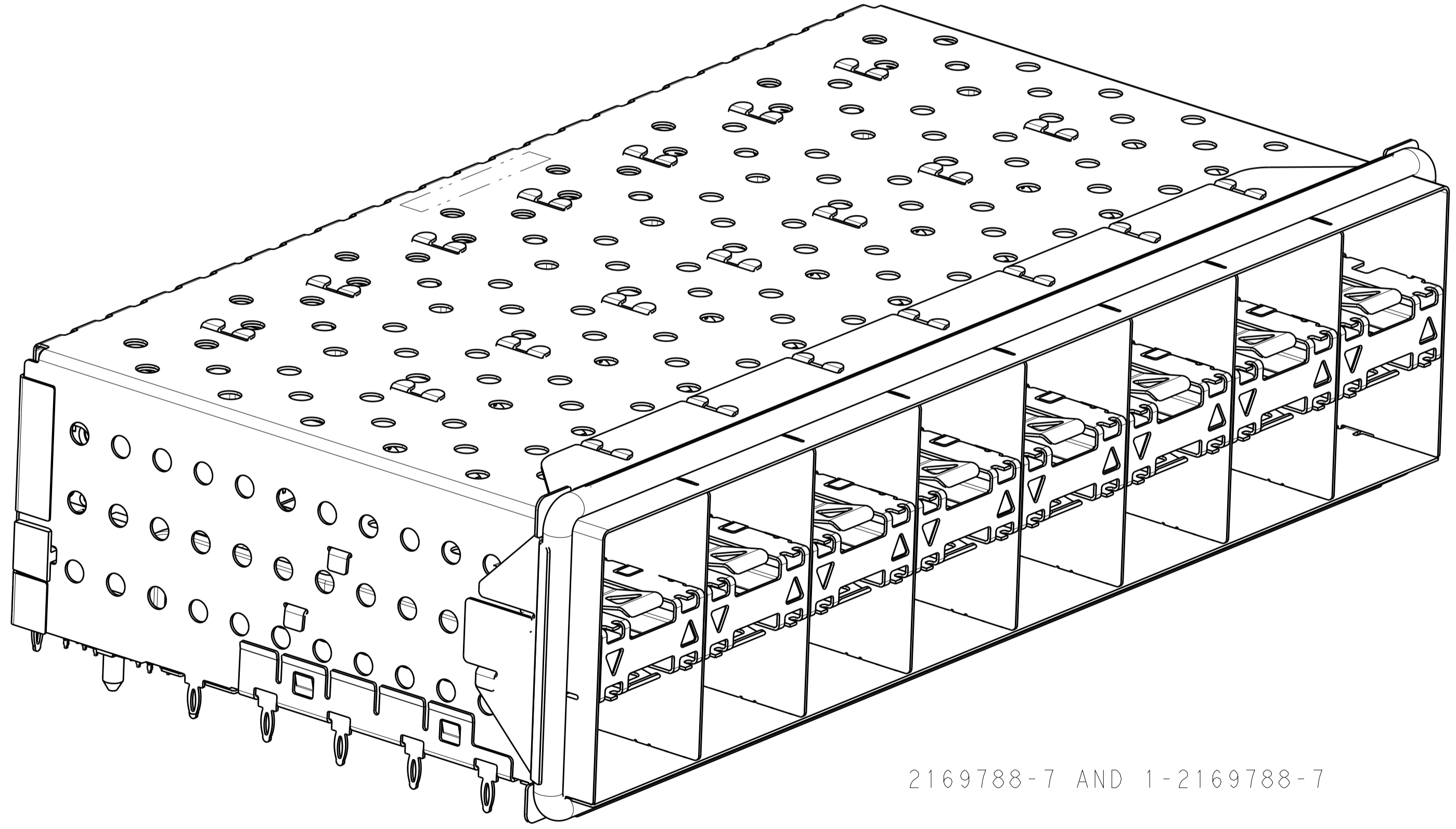

2169788-8 AND 1-2169788-8

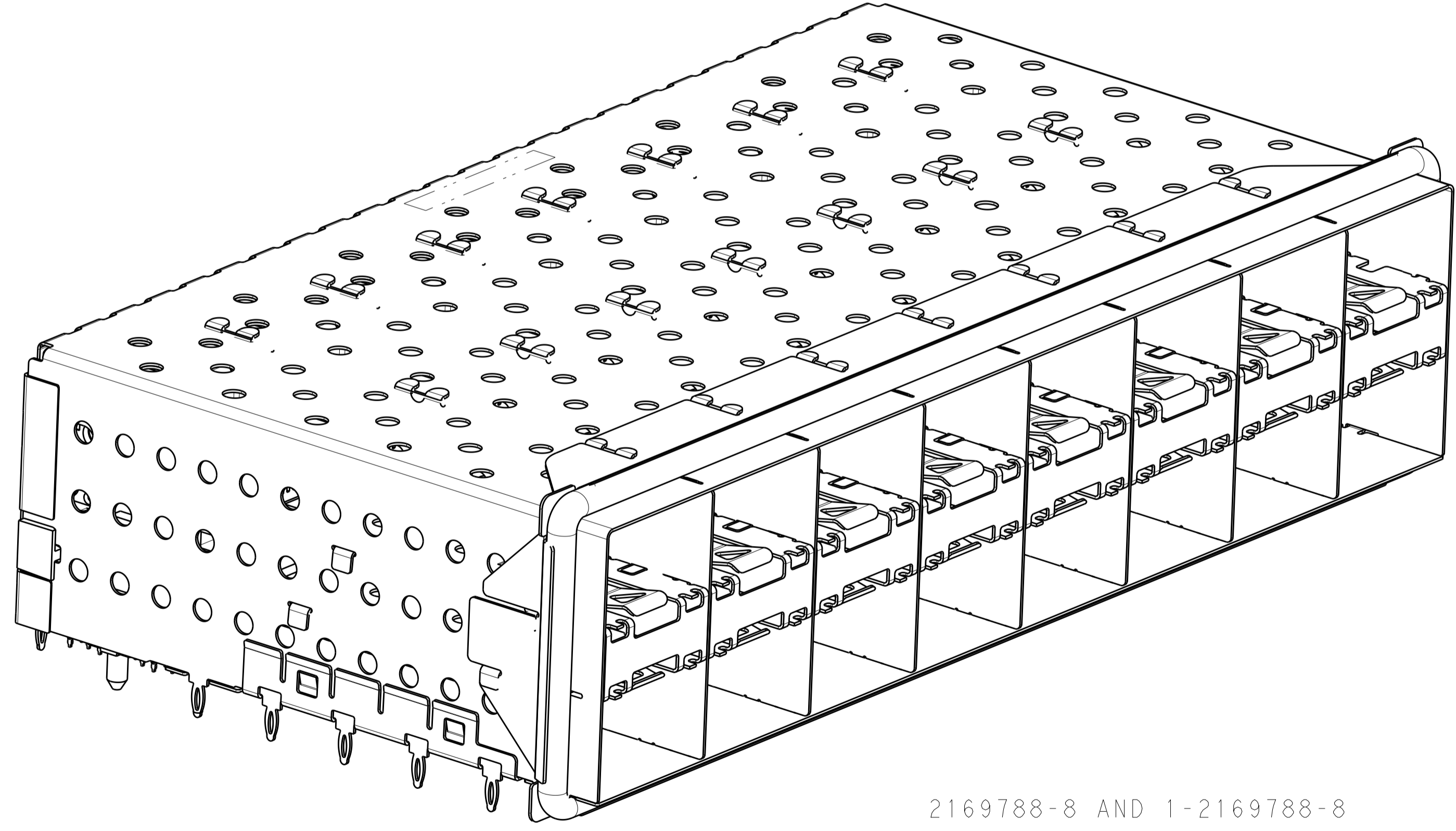

THIS DRAWING IS A CONTROLLED DOCUMENT.		OWN	C. VALENTINI	18JAN2011	 TE Connectivity NAME CAGE AND PT CONNECTOR ASSEMBLY, WITH EMI GASKET, PRESS FIT, 2X8, STACKED SFP+
DIMENSIONS:		CHK	P. RECCE	18JAN2011	
mm		APVD	P. RECCE	18JAN2011	
0 PLC ±0.1 1 PLC ±0.1 2 PLC ±0.1 3 PLC ±0.1 4 PLC ±0.1 ANGLES ±0.1		PRODUCT SPEC	108-2331	APPLICATION SPEC	
MATERIAL	FINISH	WEIGHT	114-13219	SIZE	CAGE CODE DRAWING NO
	SEE TABLE	CUSTOMER DRAWING		A100779	C=2169788
		SCALE	3:1	SHEET	2 OF 4
		REV	D		

LOC	DIST	REVISIONS			
P	LTN	DESCRIPTION	DATE	DWN	APVD
-	-	SEE SHEET 1	-	-	-

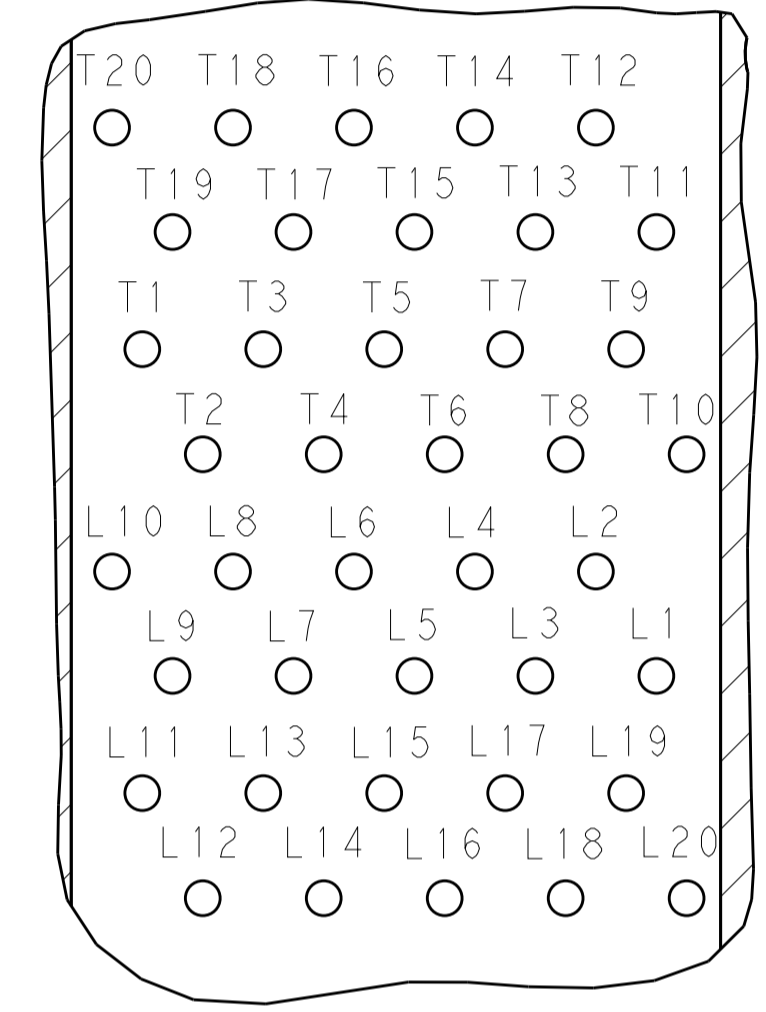
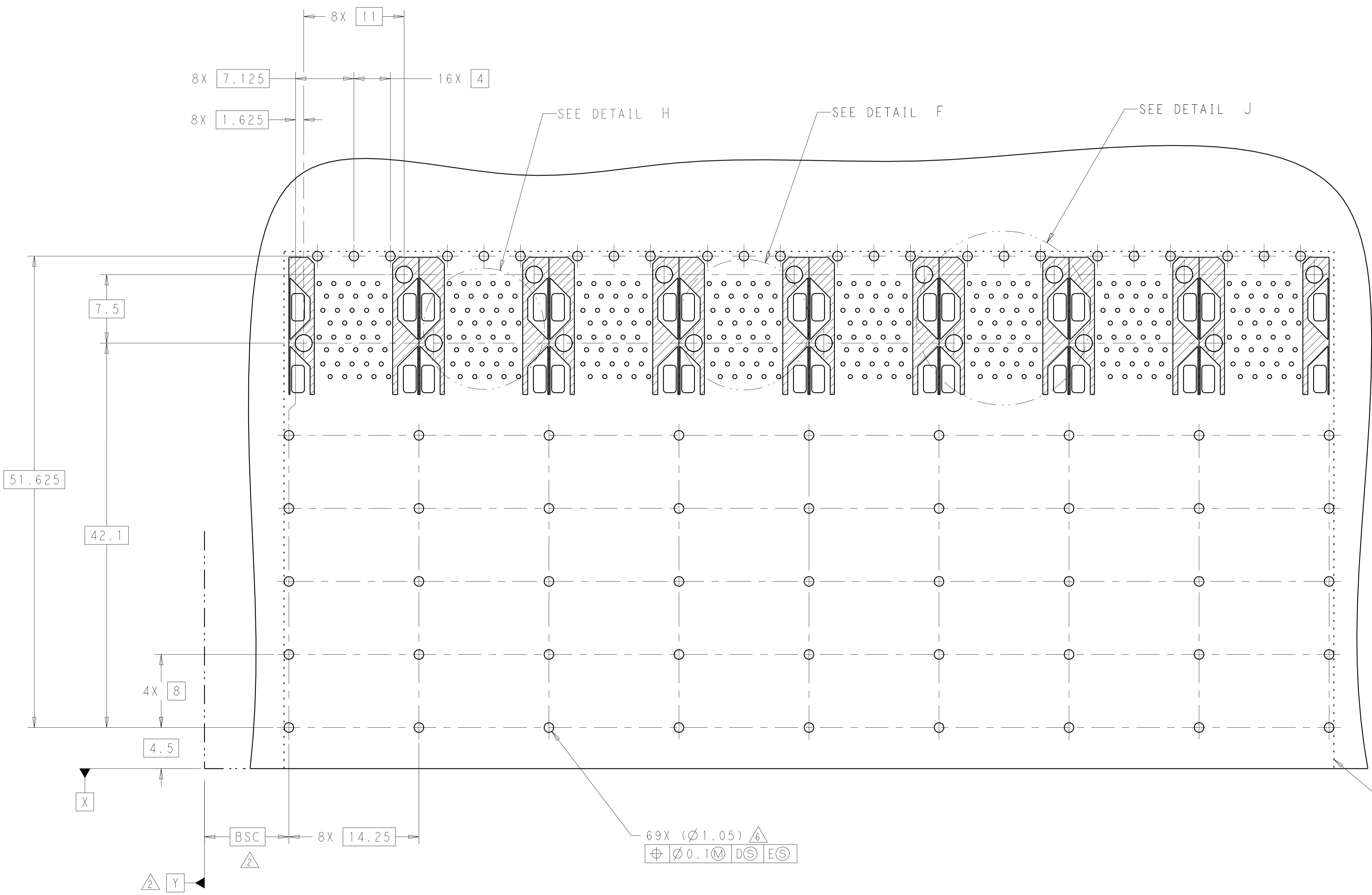

DETAIL H  
 CONNECTOR PIN-OUT  
 COMPONENT SIDE OF BOARD  
 8X INDIVIDUALLY  
 SCALE 10:1

RECOMMENDED PCB LAYOUT  
 COMPONENT SIDE OF BOARD  
 SCALE 4:1

69X (Ø1.05)  $\Delta$   
 $\oplus \ominus \varnothing 0.1 \text{ M} \text{ D S} \text{ E S}$

THIS DRAWING IS A CONTROLLED DOCUMENT.		DWN C. VALENTINI 18JAN2011	TE Connectivity
DIMENSIONS: mm		CHK P. RECCE 18JAN2011	
TOLERANCES UNLESS OTHERWISE SPECIFIED:		APVD P. RECCE 18JAN2011	NAME CAGE AND PT CONNECTOR ASSEMBLY, WITH EMI GASKET, PRESS FIT, 2X8, STACKED SFP+
		PRODUCT SPEC 108-2331	RESTRICTED TO
MATERIAL		APPLICATION SPEC 114-13219	SIZE A100779C=2169788
FINISH		WEIGHT	SCALE 3:1 SHEET 3 OF 4 REV D
SEE TABLE		CUSTOMER DRAWING	