

LOC	DIST	REVISIONS					
GP	00	P	LTN	DESCRIPTION	DATE	OWN	APVD
		A		RELEASED PER ECO-14-008758	13JUN2014	CJV	PAR
		B		REVISED PER ECO-15-010819	10AUG2015	PP	SH
		C1		REVISED PER ECR-21-002578	02MAR2021	SZ	SZ

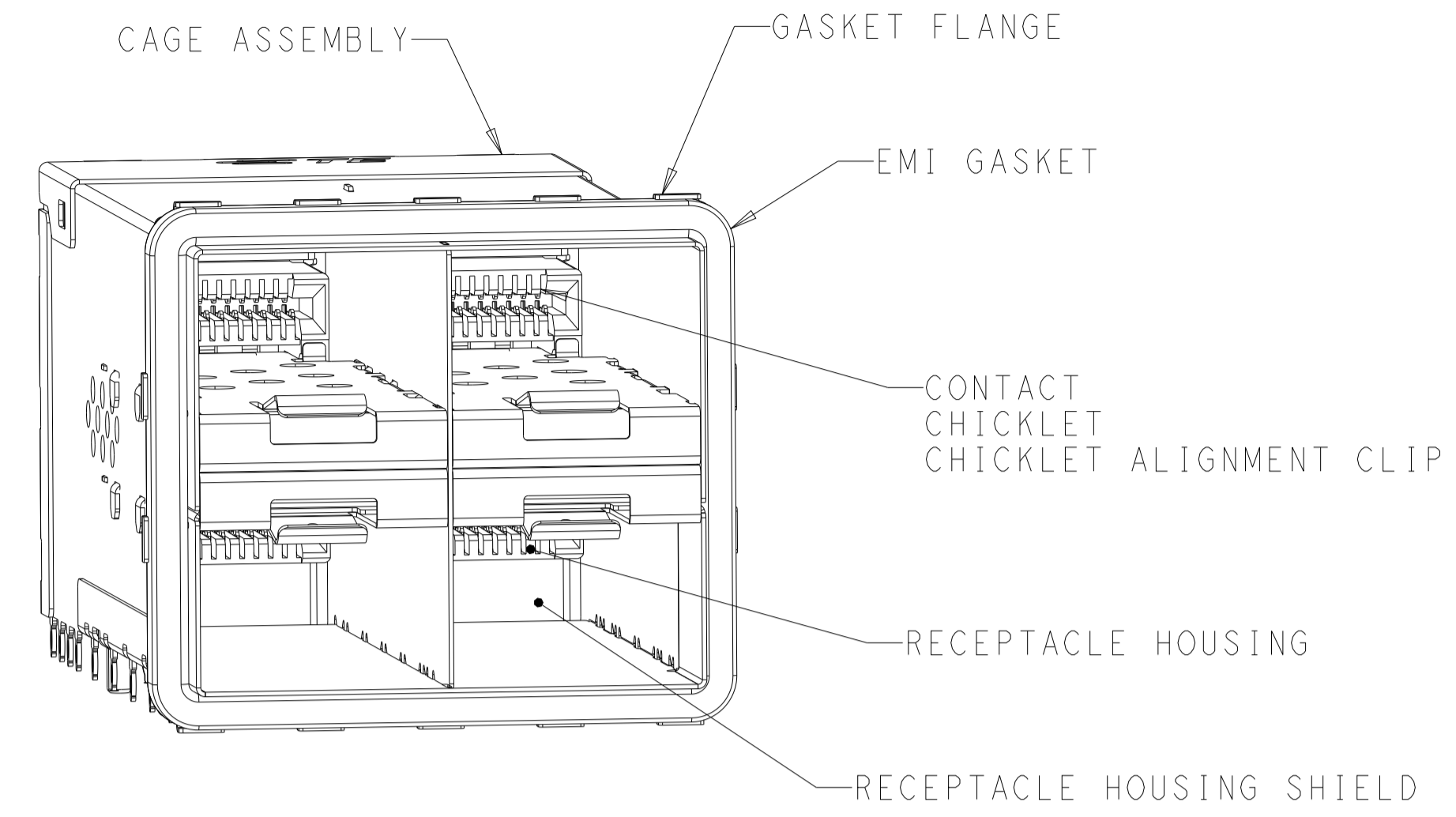

2198325-1
SCALE 3:1

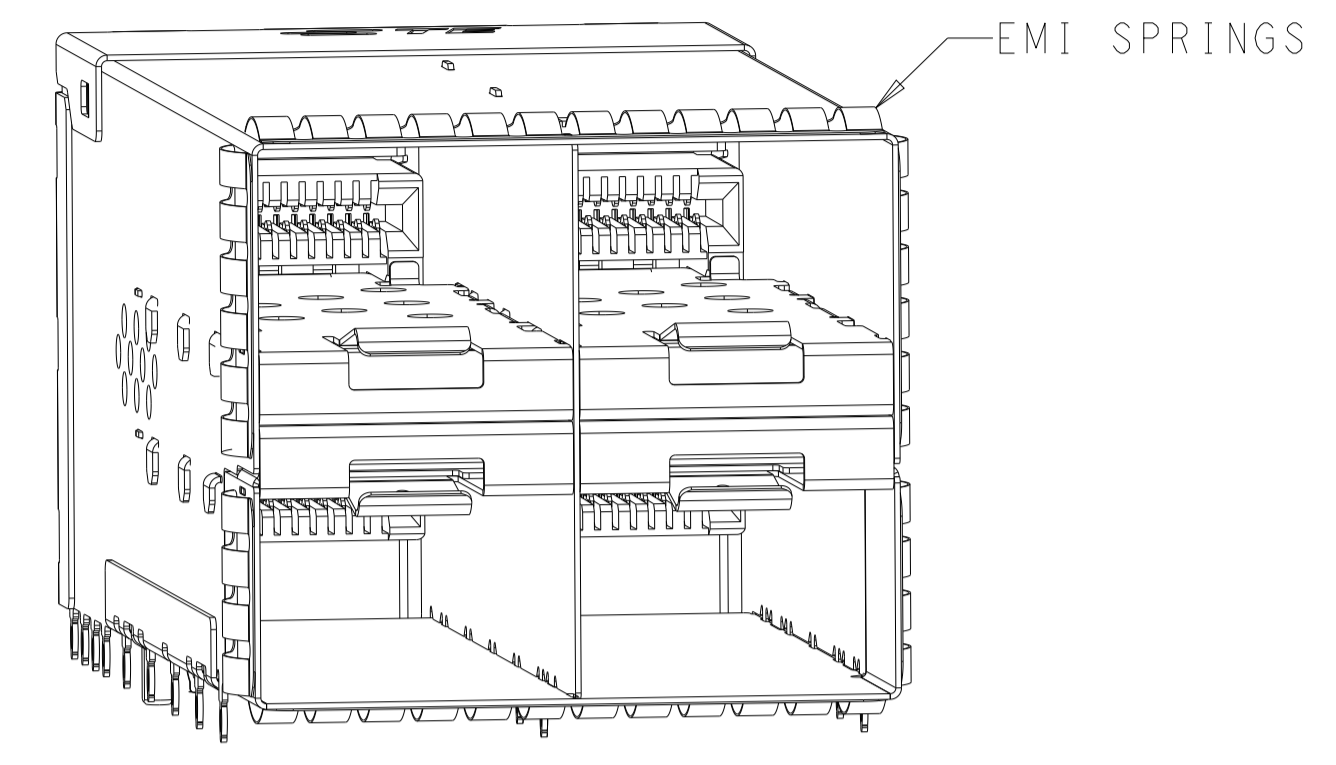

2198325-5
SCALE 3:1

- MATERIALS:
 CAGE ASSEMBLY - NICKEL-SILVER ALLOY PER ASTM B 122
 CONNECTOR HOUSING - LCP, BLACK, UL 94V-O RATED
 CONNECTOR HOUSING SHIELD - COPPER ALLOY
 CHICKLET - LCP, BLACK, UL 94V-O RATED
 CHICKLET ALIGNMENT CLIP - PBT
 CONTACT - COPPER ALLOY
 EMI GASKET - ELASTOMERIC
 GASKET FLANGE - STAINLESS STEEL
 EMI SPRINGS - PHOSPHOR BRONZE PER ASTM B 103,
 0.8µm MIN TIN PER ASTM B 545
 LIGHT PIPE - POLYCARBONATE
 LIGHT PIPE HOUSING - ZINC ALLOY

- CONTACT FINISH:
 CONFORMS TO THE REQUIREMENTS OF PRODUCT SPECIFICATION 108-2481, BASED ON EIA/ECA-364-1000.01A, CONTROLLED ENVIRONMENT APPLICATIONS) ON MATING INTERFACE, TIN ON NEEDLE EYE

- PCB MINIMUM THICKNESS = 1.5mm

△ FOR HOLE SIZE AND PLATINGS, SEE APPLICATION SPECIFICATION 114-13319

△ LIGHT PIPE PAD LAYOUT IS FOR 0805 LOW PROFILE LED PACKAGE WITH A HEIGHT OF 0.8mm

△ DIMENSIONS APPLY FOR EMI SPRINGS ONLY

△ THE ENTIRE AREA OF THE CONNECTOR FOOTPRINT, INDICATED BY THE DASHED LINE, TO BE CONSIDERED THE KEEPOUT AREA FOR COMPONENTS AND SIGNAL TRACES, TOP SIDE ONLY, TOP SIDE TRACES ALLOWED WITHIN CONNECTOR HOLE PATTERN

△ AIRFLOW ENHANCE VERSION

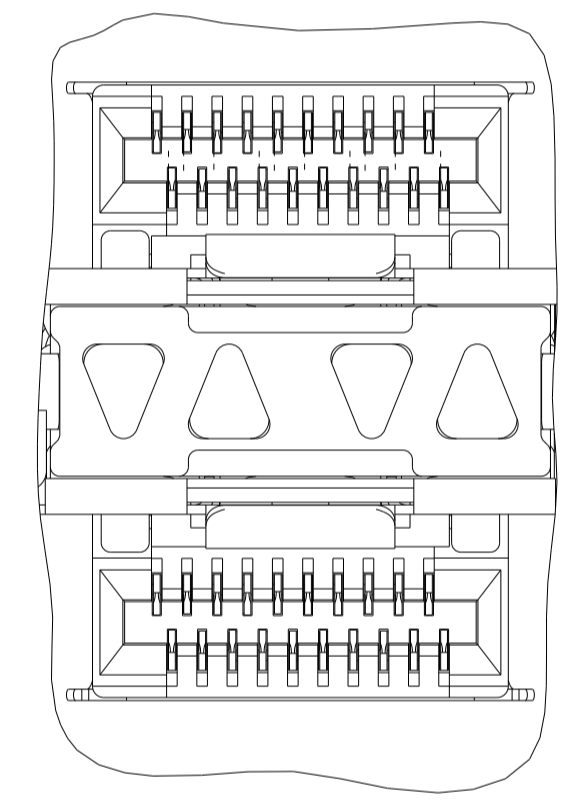

INNER/OUTER LIGHT PIPES
2198325-2, 2198325-6
SCALE 5:1

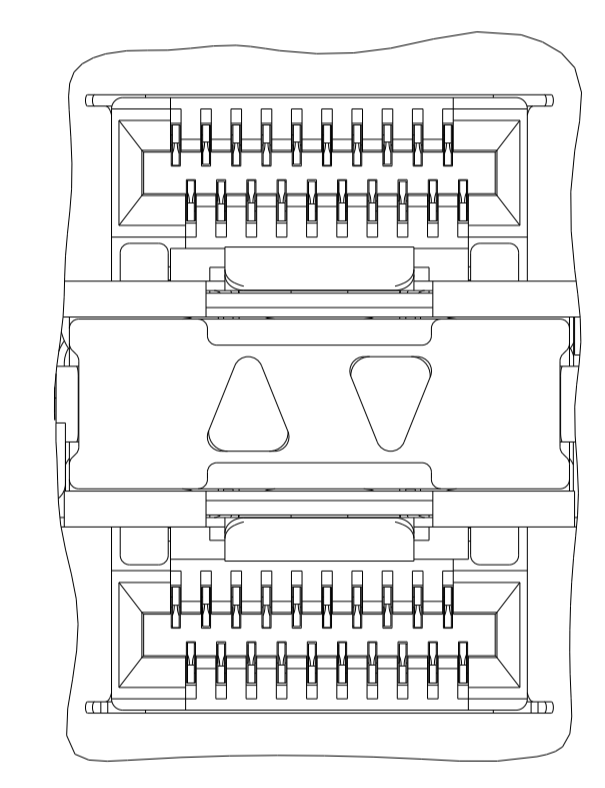

INNER LIGHT PIPES
2198325-3, 2198325-7
SCALE 5:1

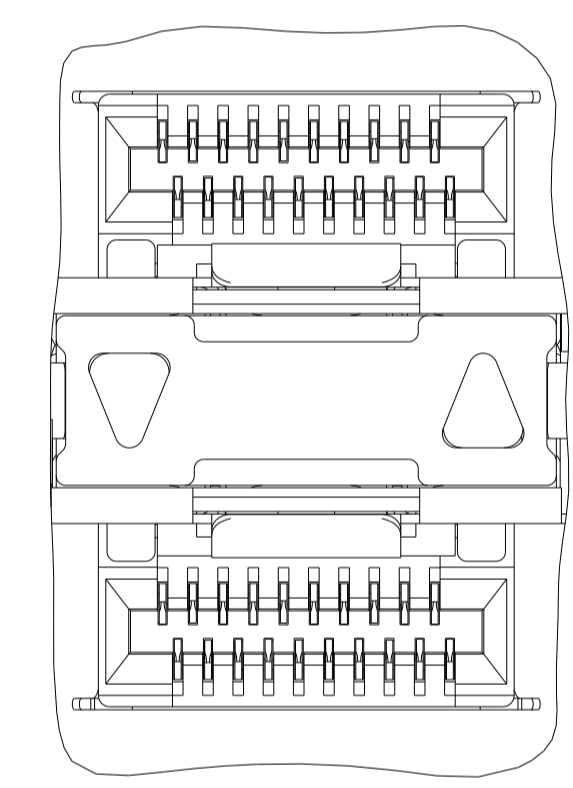

OUTER LIGHT PIPES
2198325-4, 2198325-8
SCALE 5:1

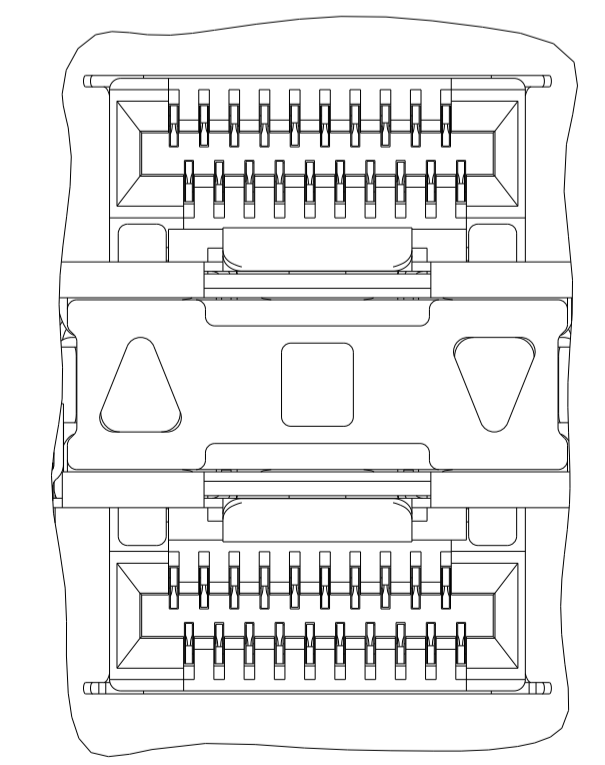

CENTER/REVERSED OUTER LIGHT PIPES
1-2198325-7, 1-2198325-9
SCALE 5:1

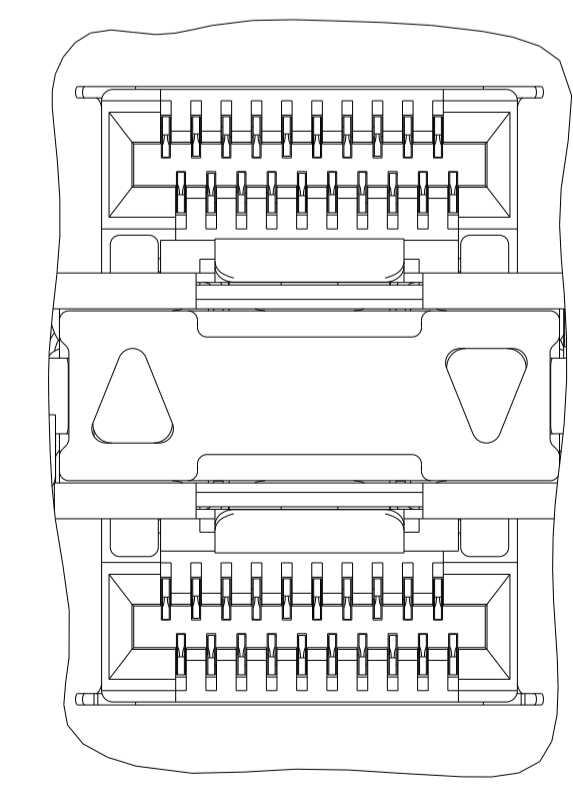

REVERSED OUTER LIGHT PIPES
1-2198325-8, 2-2198325-0
SCALE 5:1

△	31	EMI SPRINGS	REVERSE OUTER	3-2198325-3
△	31	EMI SPRINGS	CENTER/REVERSE OUTER	3-2198325-2
	31	EMI SPRINGS	CENTER/REVERSE OUTER	3-2198325-1
	31	EMI SPRINGS	NONE	3-2198325-0
	31	EMI SPRINGS	REVERSED OUTER	2-2198325-0
			CENTER/REVERSED OUTER	1-2198325-9
	33.75	EMI GASKET	REVERSED OUTER	1-2198325-8
			CENTER/REVERSED OUTER	1-2198325-7
	31	EMI SPRINGS	OUTER	2198325-8
			INNER	2198325-7
			INNER/OUTER	2198325-6
			NONE	2198325-5
	33.75	EMI GASKET	OUTER	2198325-4
			INNER	2198325-3
			INNER/OUTER	2198325-2
			NONE	2198325-1
(E)	CAGE TYPE	LIGHT PIPE CONFIGURATION		PART NUMBER

THIS DRAWING IS A CONTROLLED DOCUMENT.

OWN: M. E. CONNER 06OCT2011
 CHK: M. D. MORRISON 06OCT2011
 APVD: M. D. MORRISON 07OCT2011

TE Connectivity

RECEPTACLE ASSEMBLY, 2X2, STACKED, zSFP+

SIZE: A1 00779 C=2198325

SCALE: 4:1 SHEET: 1 OF 6 REV: C1

LOC		DIST		REVISIONS				
P	LTN	DATE	DMN	APVD	DESCRIPTION	DATE	DMN	APVD
-	-	-	-	-	SEE SHEET 1	-	-	-

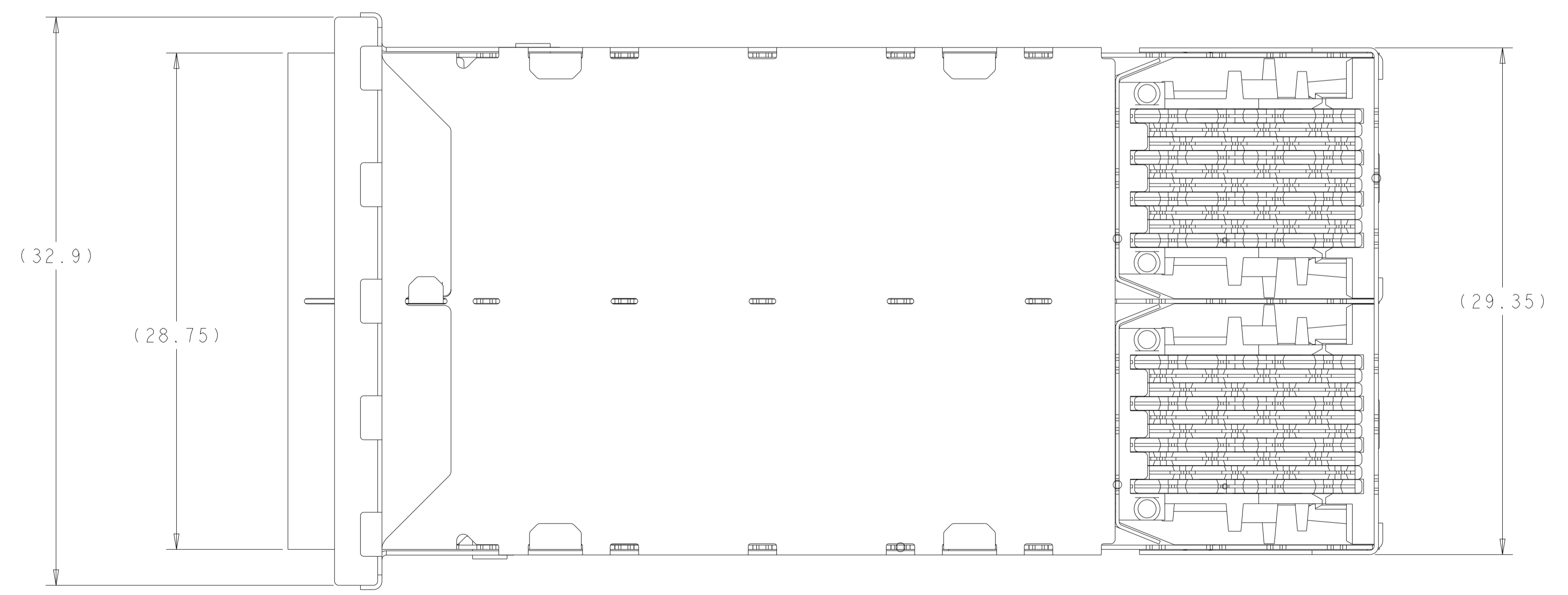
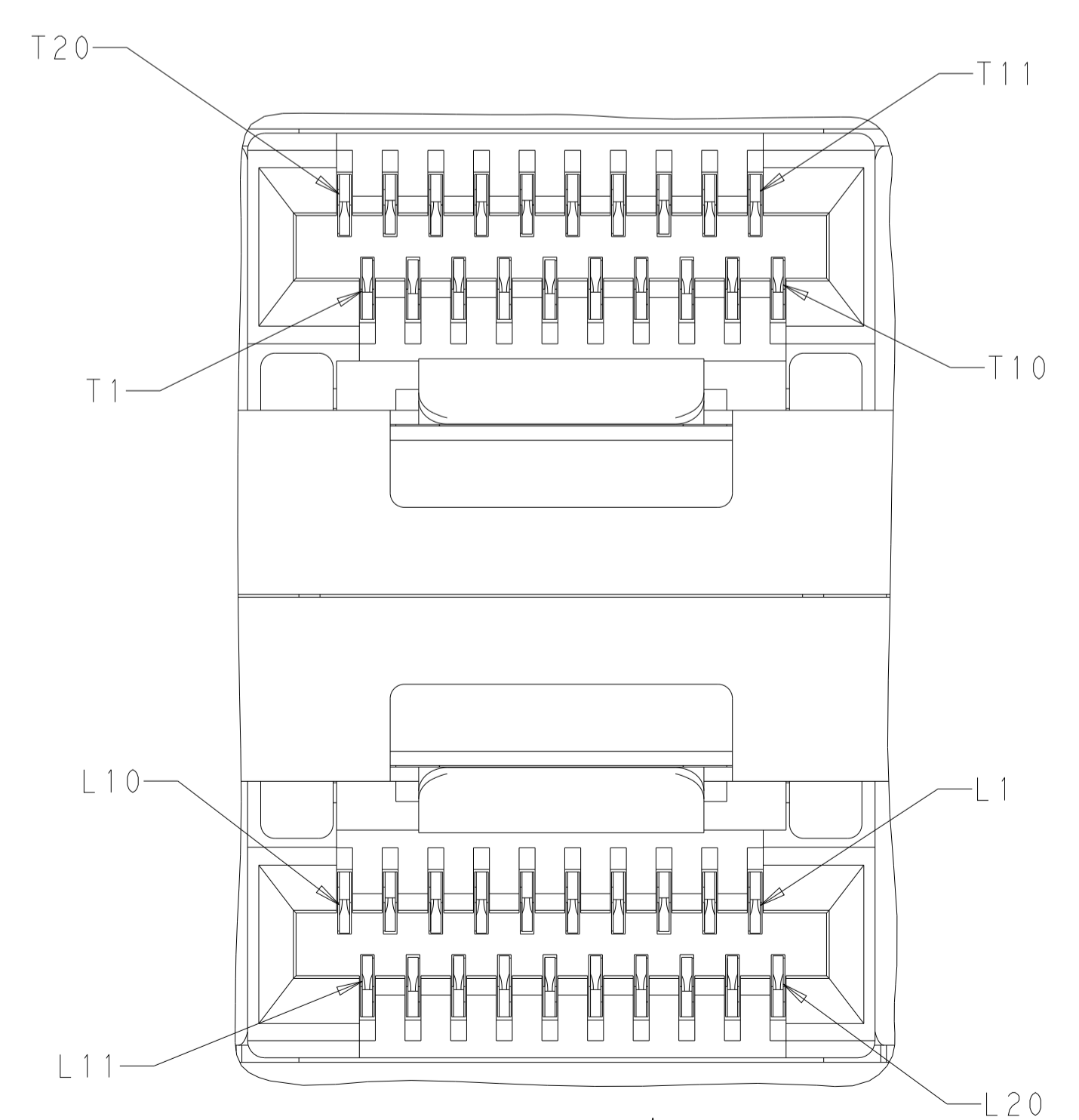
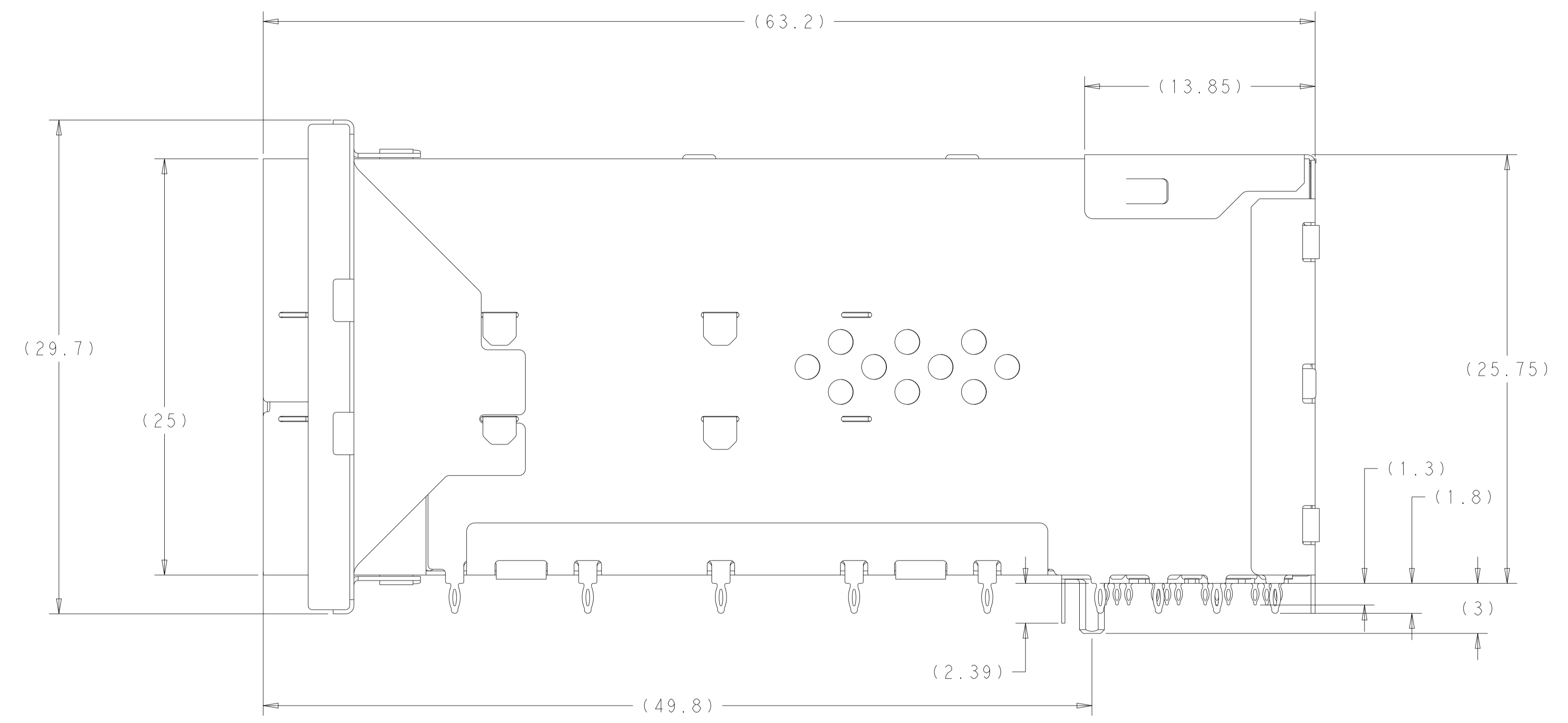
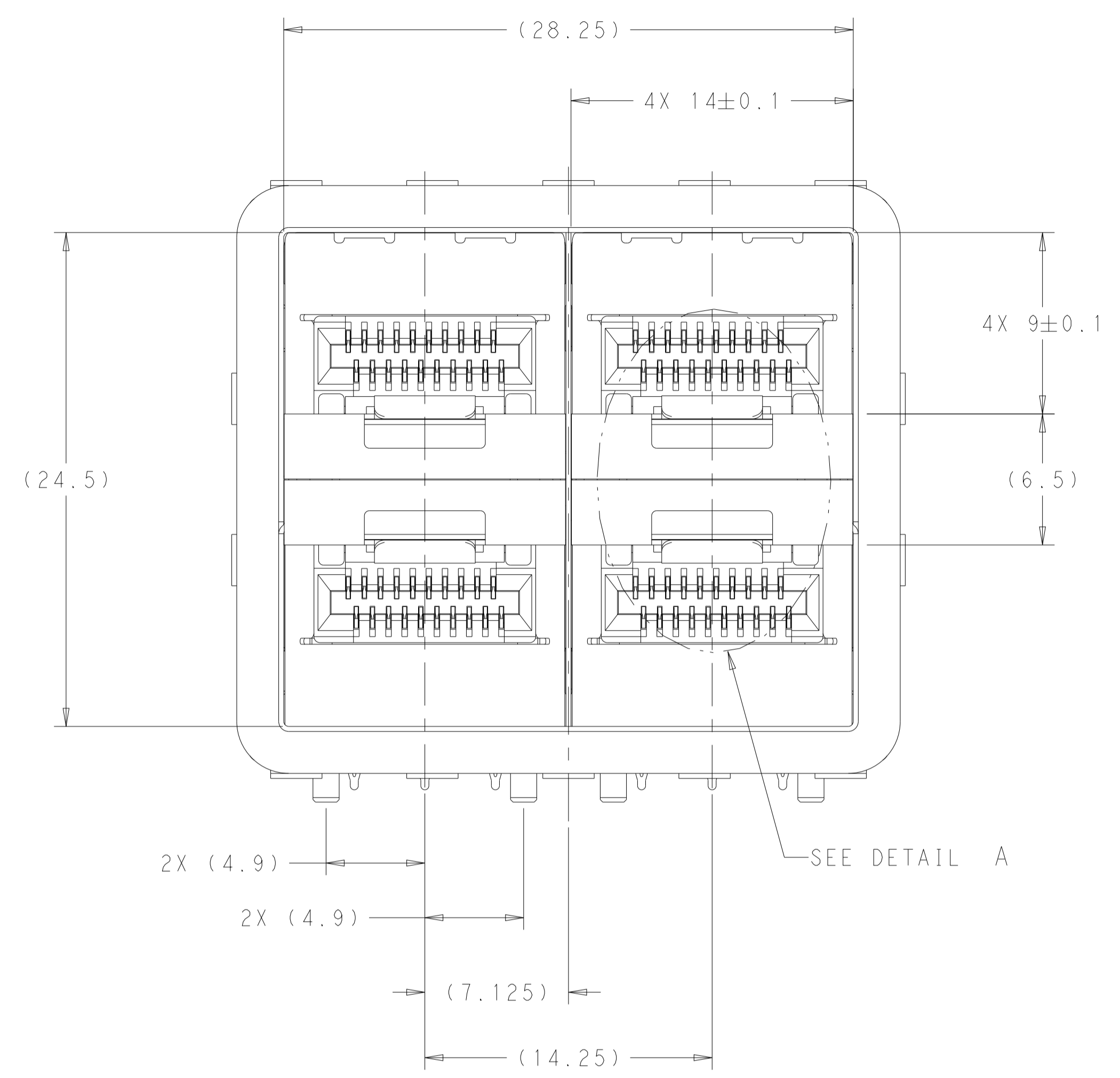

THIS DRAWING IS A CONTROLLED DOCUMENT.

OWN: M. E. CONNER 06OCT2011	CHK: M. D. MORRISON 06OCT2011	APVD: M. D. MORRISON 07OCT2011	NAME: RECEPTACLE ASSEMBLY, 2X2, STACKED, zSFP+
DIMENSIONS: mm	TOLERANCES UNLESS OTHERWISE SPECIFIED:	PRODUCT SPEC: 108-2481	APPLICATION SPEC: 114-13319
0 PLC ±	1 PLC ±	2 PLC ±	3 PLC ±
4 PLC ±	ANGLES ±	FINISH ±	WEIGHT -
MATERIAL: SEE NOTES	SEE NOTES	Customer Drawing	SCALE 5:1 SHEET 2 OF 6 REV C1

STE TE Connectivity

LOC	DIST	REVISIONS					
GP	00	P	LTN	DESCRIPTION	DATE	DMN	APVD
		-		SEE SHEET 1	-	-	-

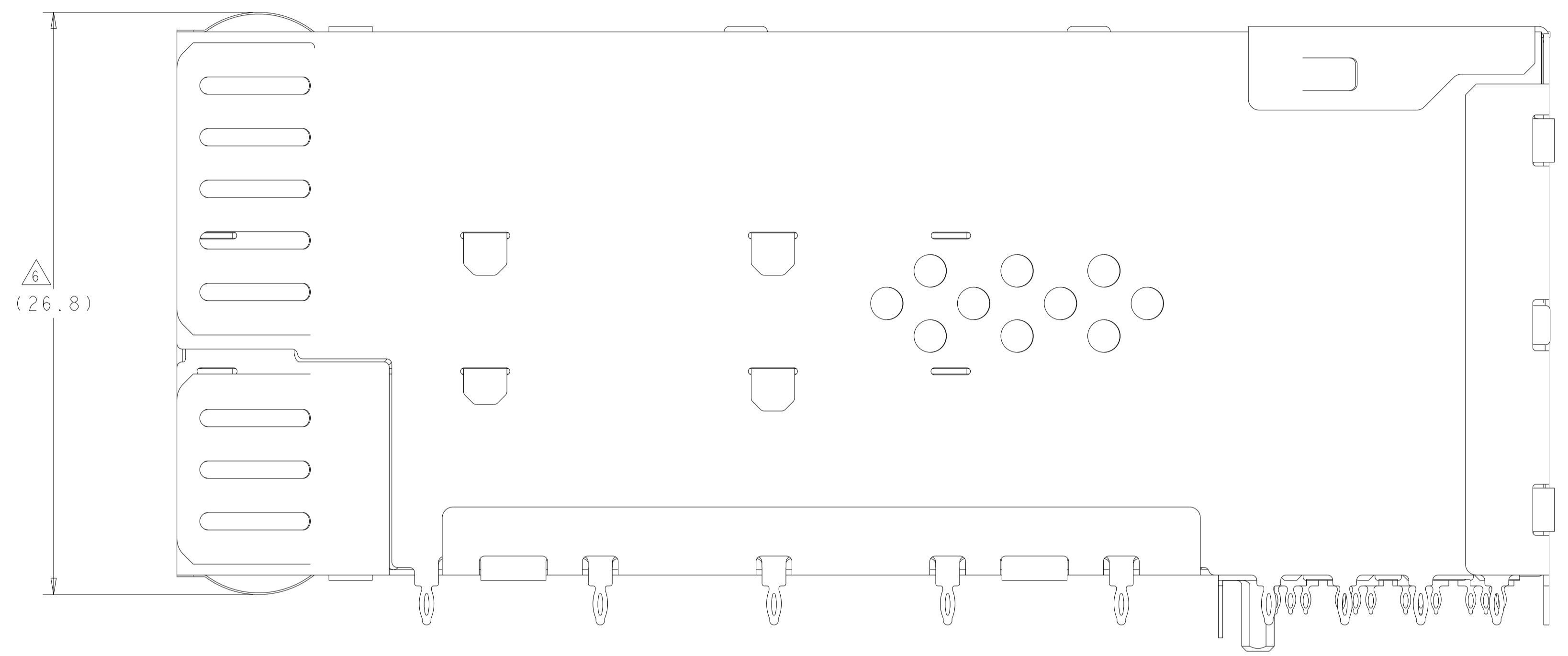
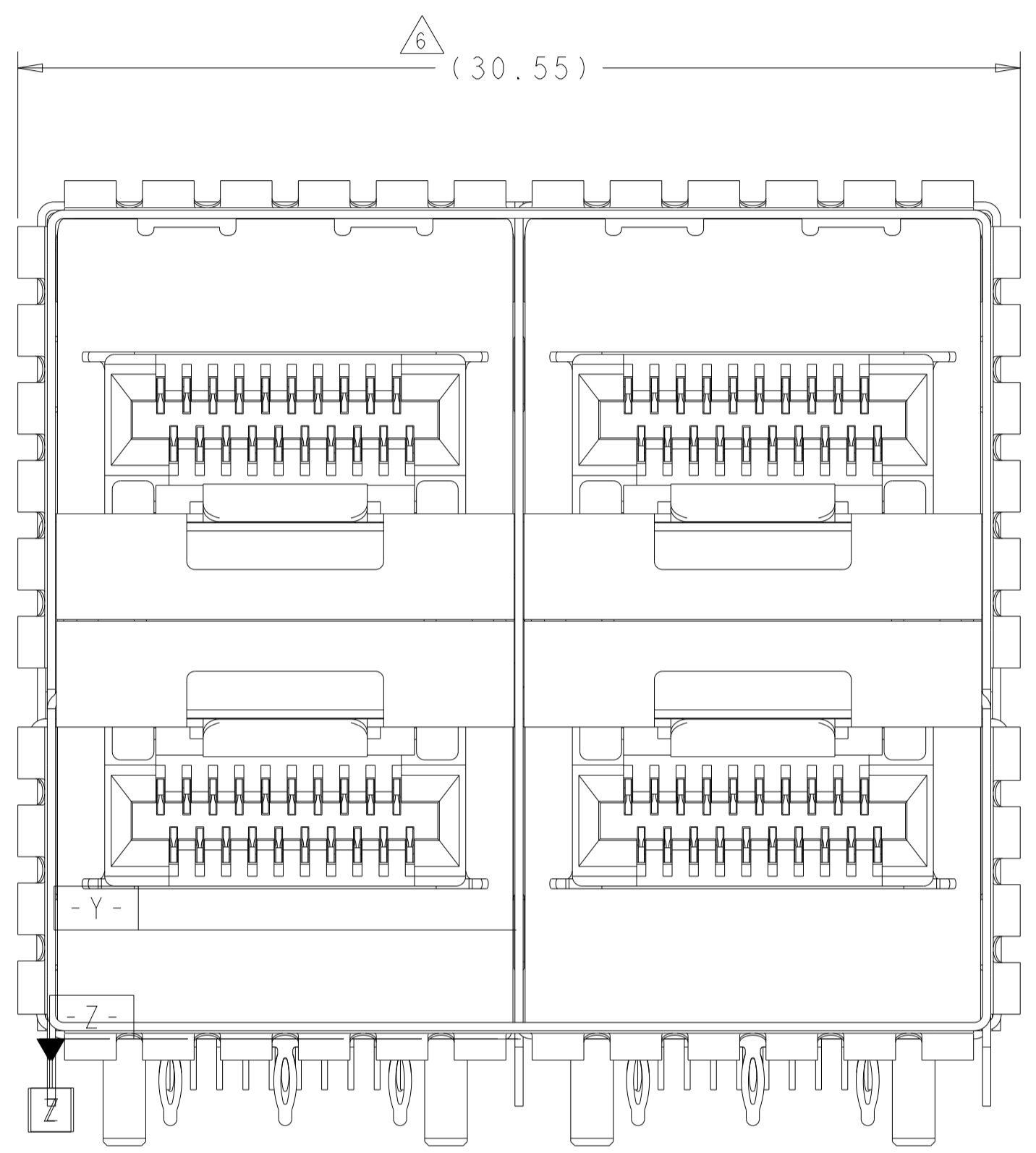

2198325-5 THRU 2198325-8, 1-2198325-9, 2-2198325-0
 EMI SPRINGS ONLY
 SCALE 6:1

THIS DRAWING IS A CONTROLLED DOCUMENT.

DMN M. E. CONNER 06OCT2011	CHK M. D. MORRISON 06OCT2011	APVD M. D. MORRISON 07OCT2011	NAME RECEPTACLE ASSEMBLY, 2X2, STACKED, zSFP+
DIMENSIONS: mm		TOLERANCES UNLESS OTHERWISE SPECIFIED:	SIZE 108-2481
0 PLC ±	1 PLC ±	2 PLC ±	3 PLC ±
4 PLC ±	ANGLES ±	FINISH ±	RESTRICTED TO
MATERIAL SEE NOTES	SEE NOTES	WEIGHT -	Customer Drawing

TE Connectivity

SCALE 4:1 SHEET 3 OF 6 REV C1

LOC	DIST	REVISIONS					
GP	00	P	LYR	DESCRIPTION	DATE	DMN	APVD
		-		SEE SHEET 1			

3-2198325-2 AIR FLOW ENHANCE VERSION UNMARKED DIMENSION SAME AS 2198325-5

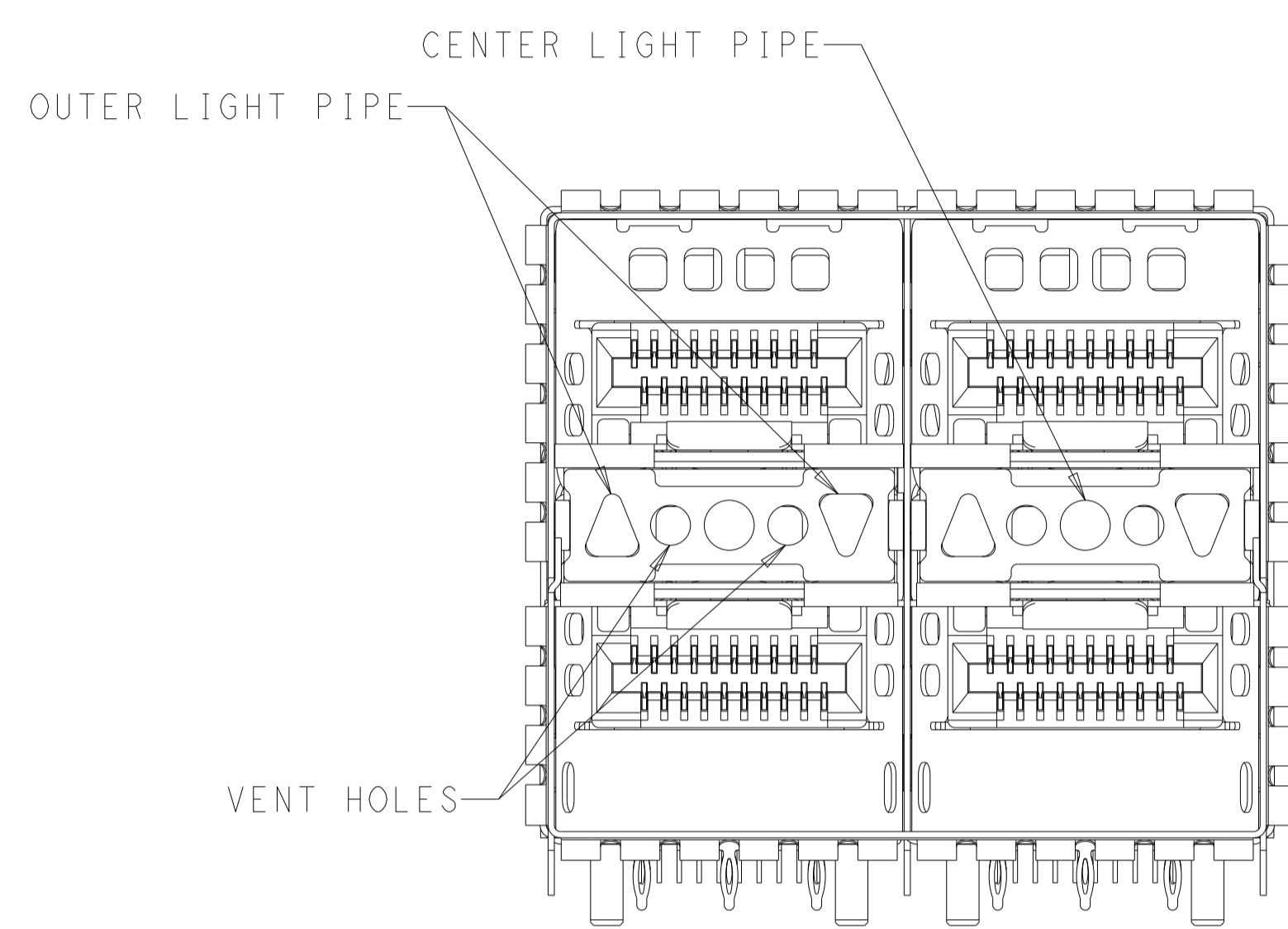

SCALE 4:1

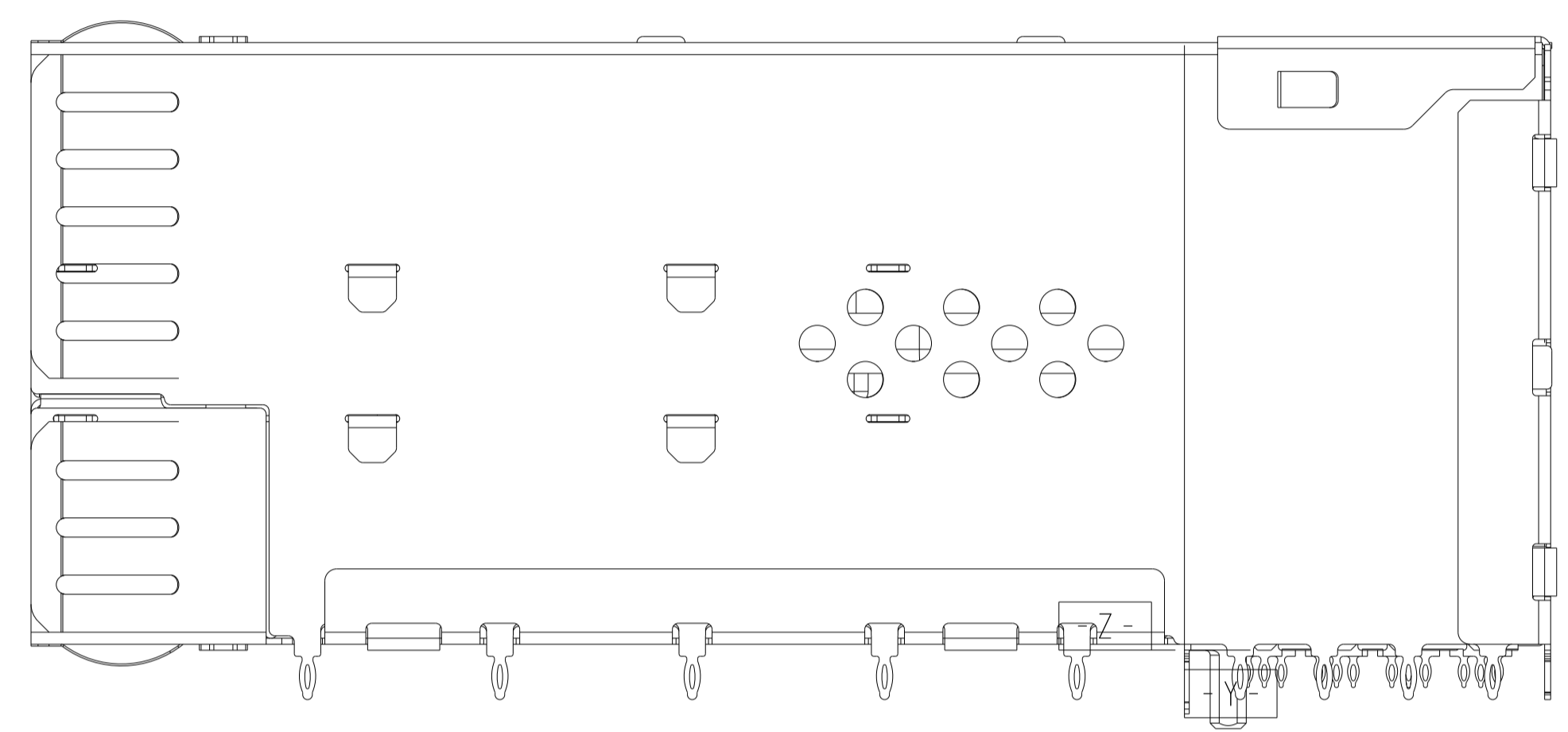

VENT HOLES PARTERN

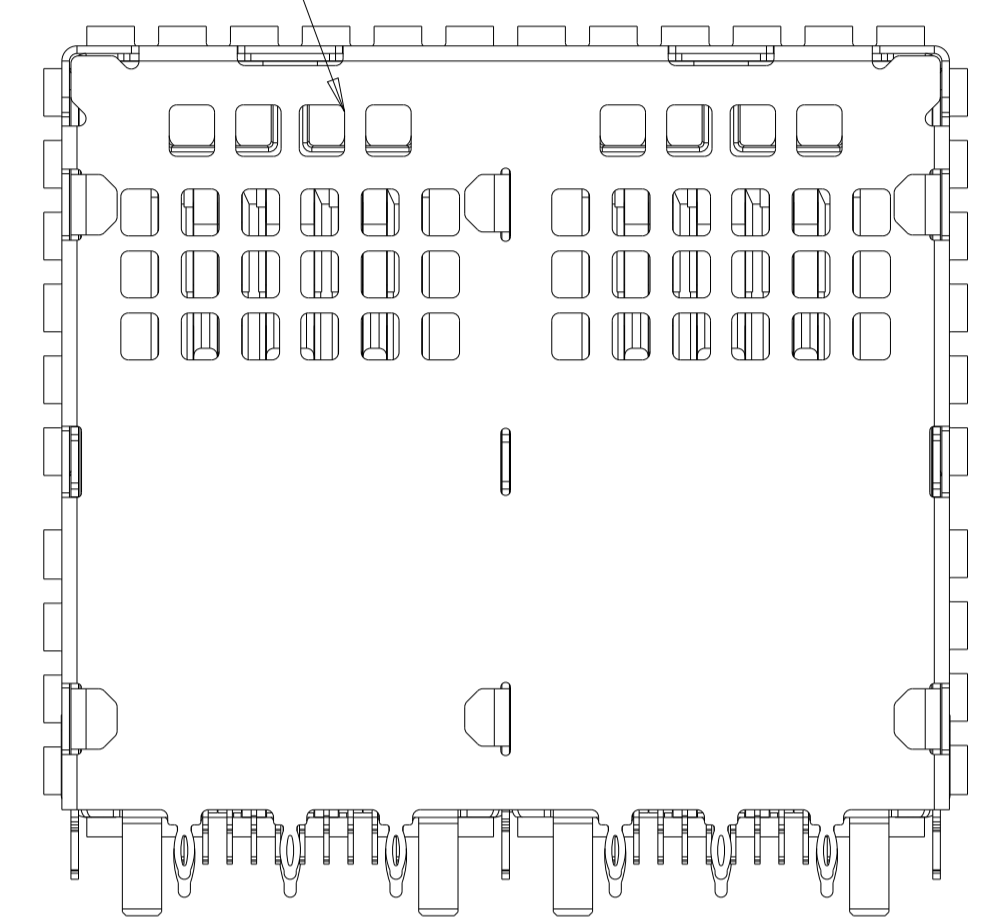

3-2198325-3 AIR FLOW ENHANCE VERSION UNMARKED DIMENSION SAME AS 2198325-5

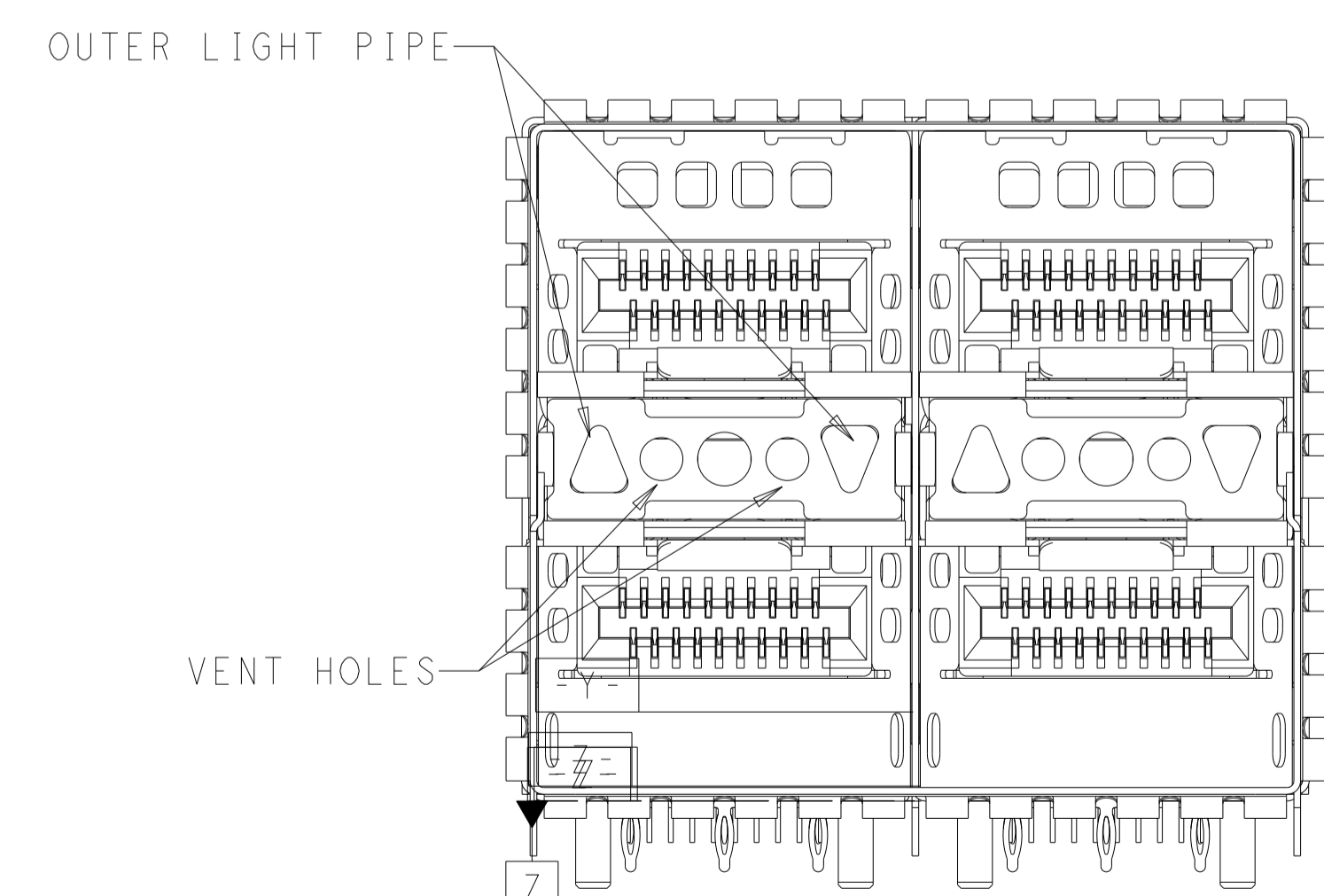

SCALE 4:1

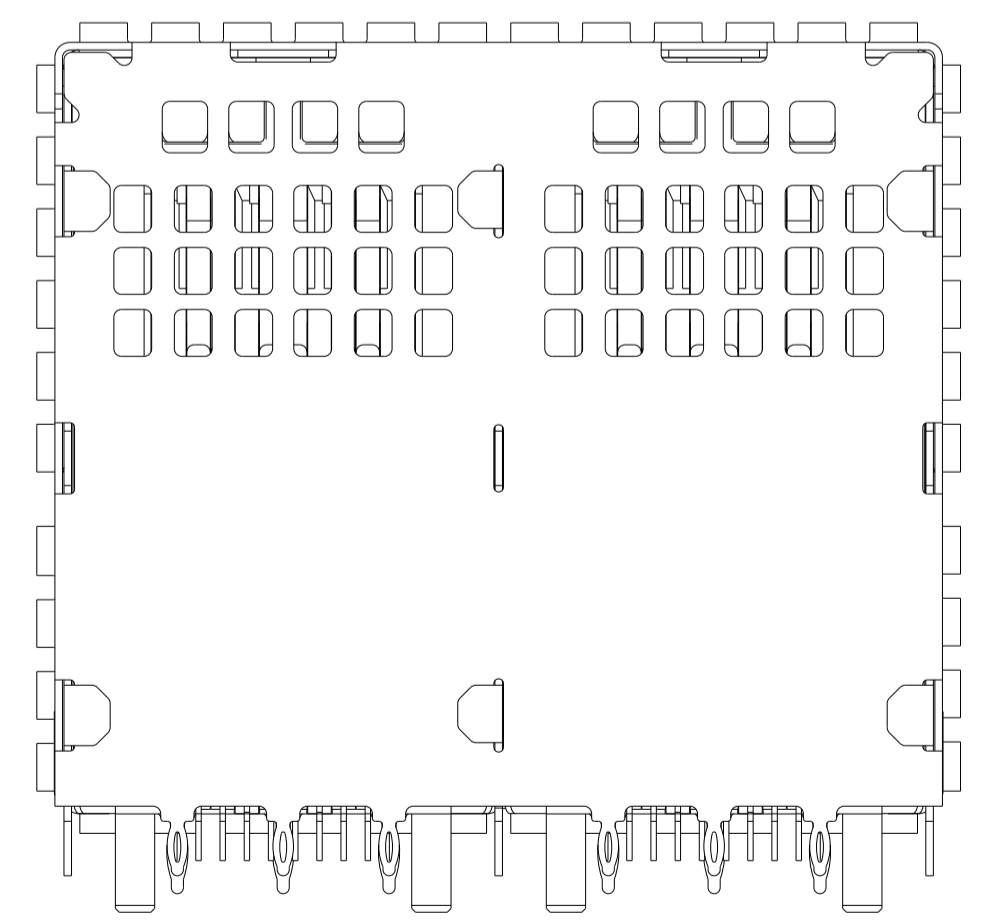
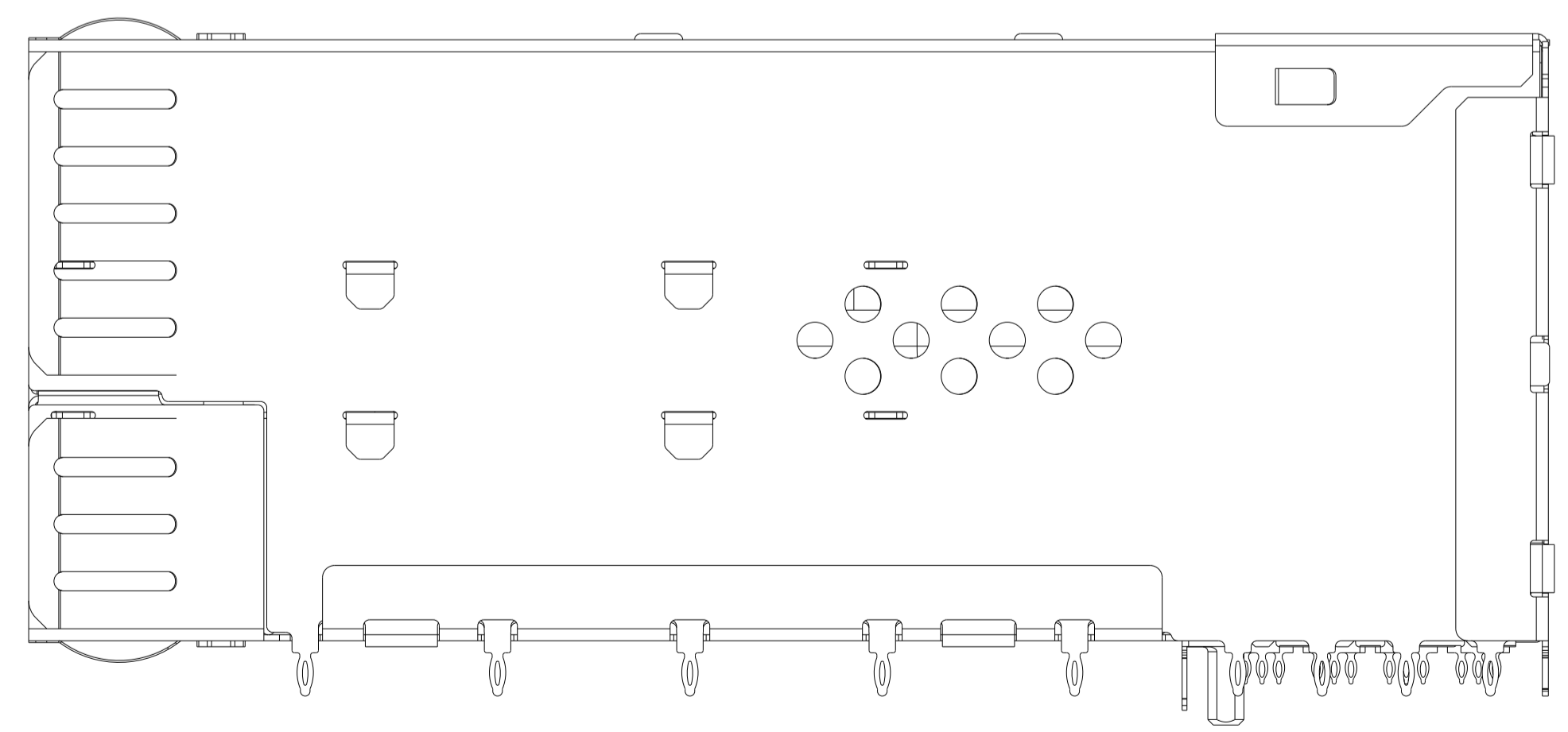

THIS DRAWING IS A CONTROLLED DOCUMENT.		DMN: M.E. CONNER 06OCT2011	TE Connectivity RECEPTACLE ASSEMBLY, 2X2, STACKED, zSFP+
DIMENSIONS: mm		CHK: M.D. MORRISON 06OCT2011	
TOLERANCES UNLESS OTHERWISE SPECIFIED: 0 PLC ±. 1 PLC ±. 2 PLC ±. 3 PLC ±. 4 PLC ±. ANGLES ±. FINISH ±.		APVD: M.D. MORRISON 07OCT2011 PRODUCT SPEC: 108-2481 APPLICATION SPEC: 114-13319 WEIGHT: -	NAME: RECEPTACLE ASSEMBLY, 2X2, STACKED, zSFP+ SIZE: A1 CAGE CODE: 00779 DRAWING NO: C=2198325 RESTRICTED TO: -
MATERIAL: SEE NOTES		Customer Drawing	
		SCALE: 4:1	SHEET 4 OF 6 REV C1

LOC		DIST		REVISIONS			
GP	00	P	LTN	DESCRIPTION	DATE	DWN	APVD
		-		SEE SHEET 1			

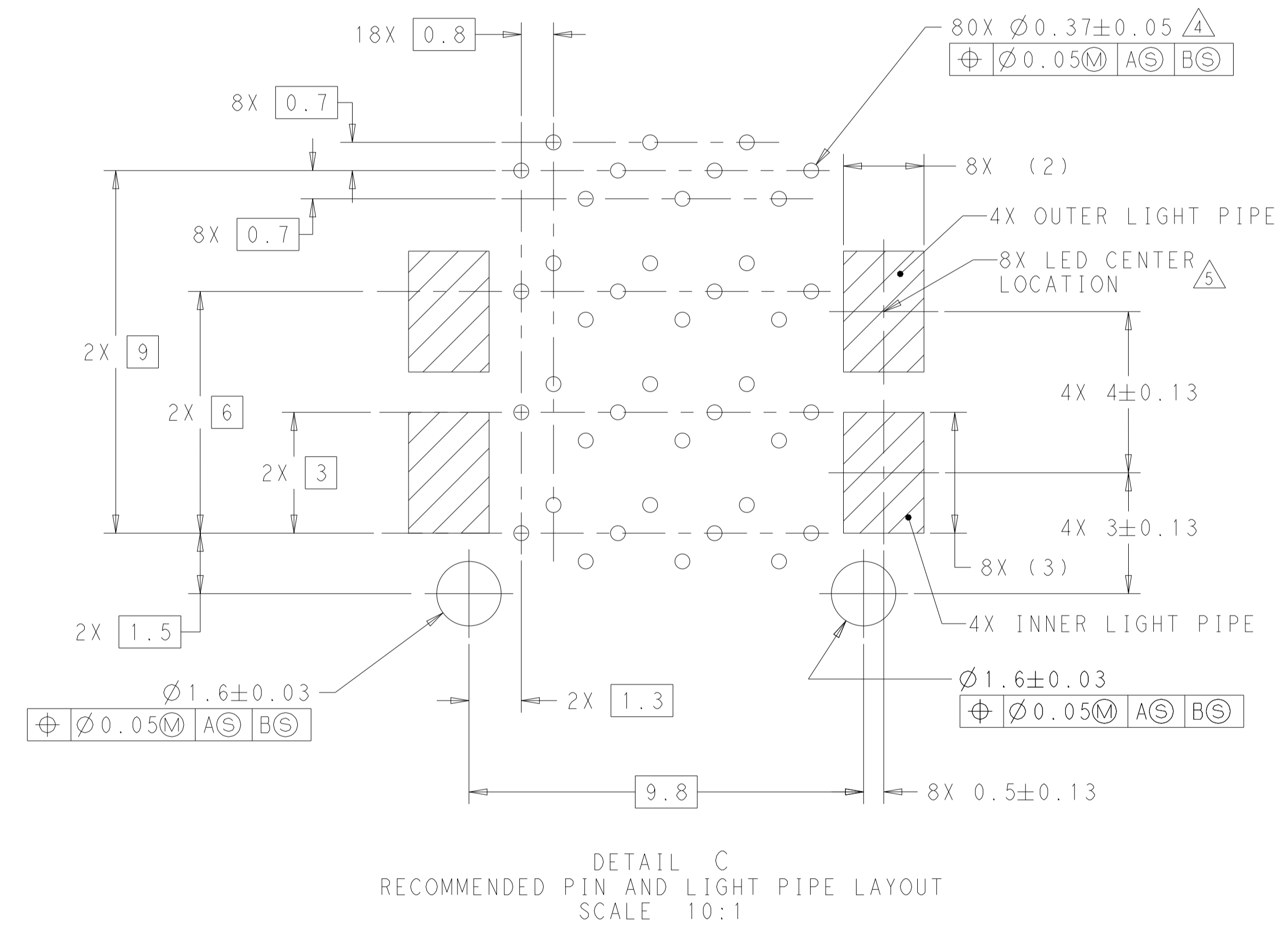
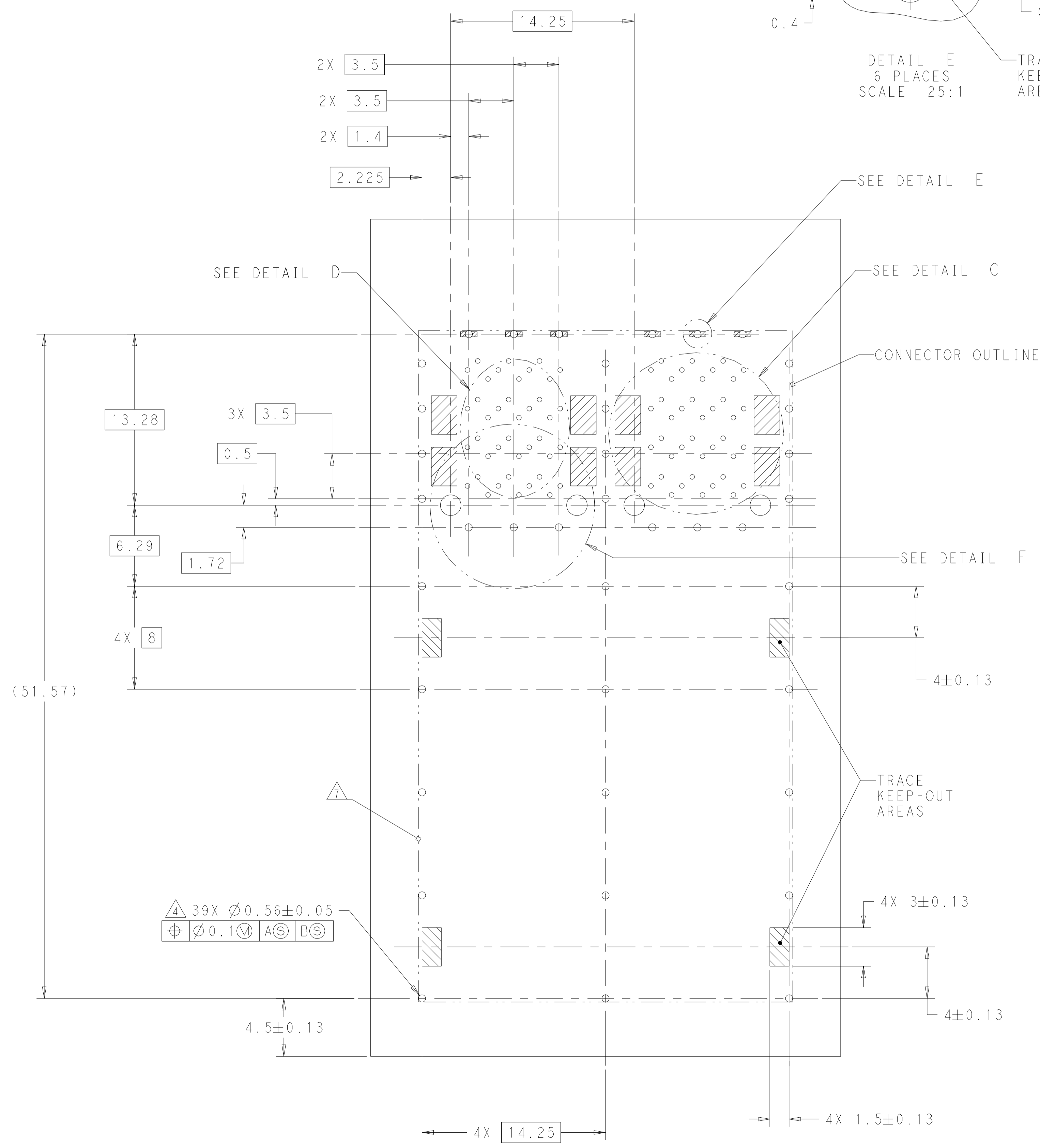
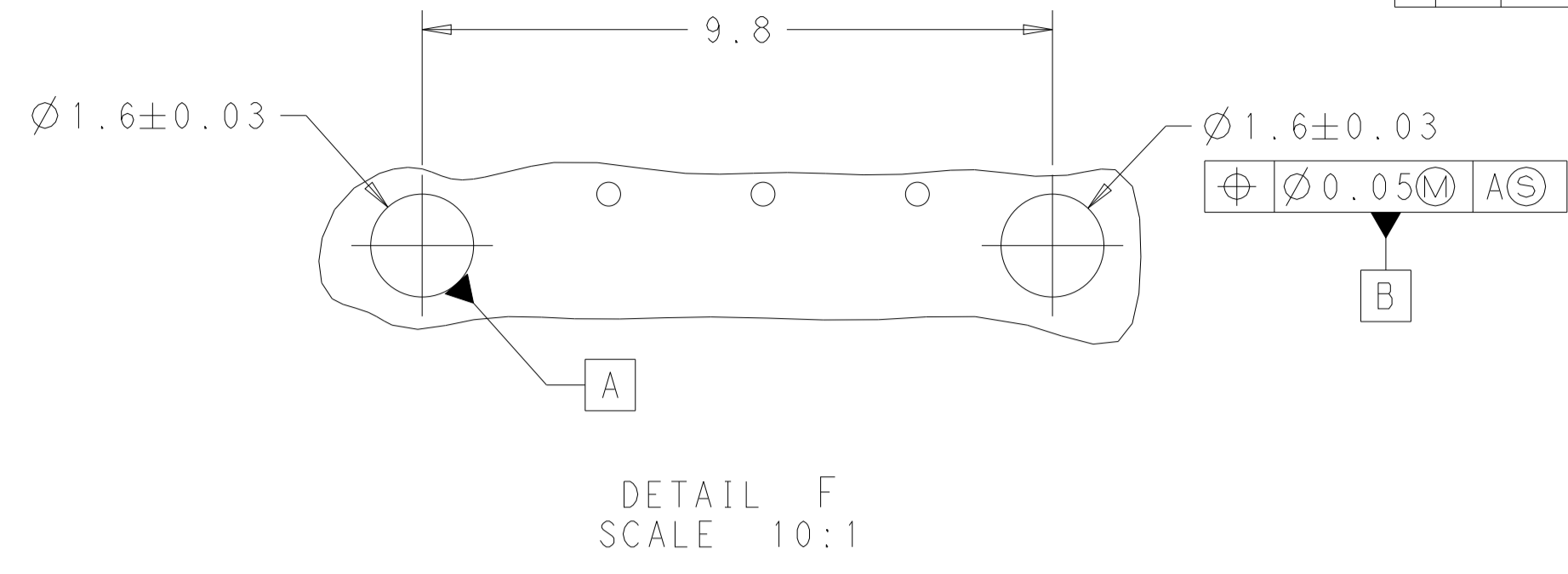
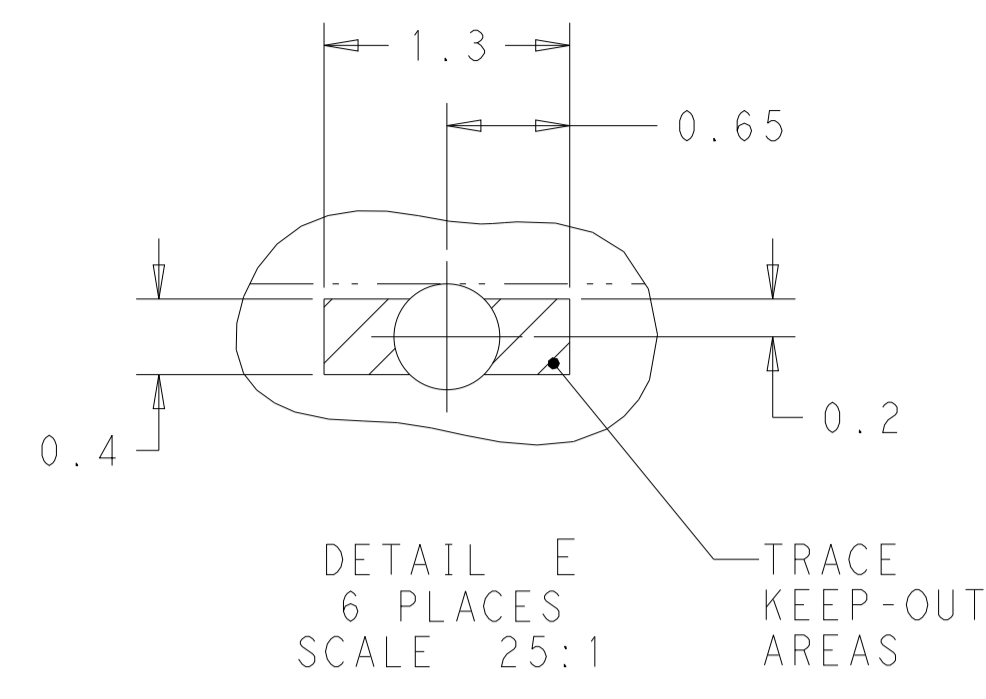

THIS DRAWING IS A CONTROLLED DOCUMENT.		DWN M.E. CONNER 06OCT2011	TE Connectivity
DIMENSIONS: mm		CHK M.D. MORRISON 06OCT2011	
TOLERANCES UNLESS OTHERWISE SPECIFIED:		APVD M.D. MORRISON 07OCT2011	NAME RECEPTACLE ASSEMBLY, 2X2, STACKED, zSFP+
0 PLC ±	1 PLC ±	PRODUCT SPEC 108-2481	SIZE CAGE CODE DRAWING NO. RESTRICTED TO
2 PLC ±	3 PLC ±	APPLICATION SPEC 114-13319	A100779C=2198325
4 PLC ±	ANGLES ±	WEIGHT	SCALE 4:1 SHEET 5 OF 6 REV C1
MATERIAL SEE NOTES	FINISH SEE NOTES	Customer Drawing	