

THIS DOCUMENT IS THE PROPERTY OF
KEYSTONE ELECTRONICS CORP. AND
SHALL NOT BE REPRODUCED, DISTRIBUTED
OR USED AS A BASIS FOR MANUFACTURE
WITHOUT PRIOR WRITTEN PERMISSION
FROM KEYSTONE ELECTRONICS CORP.

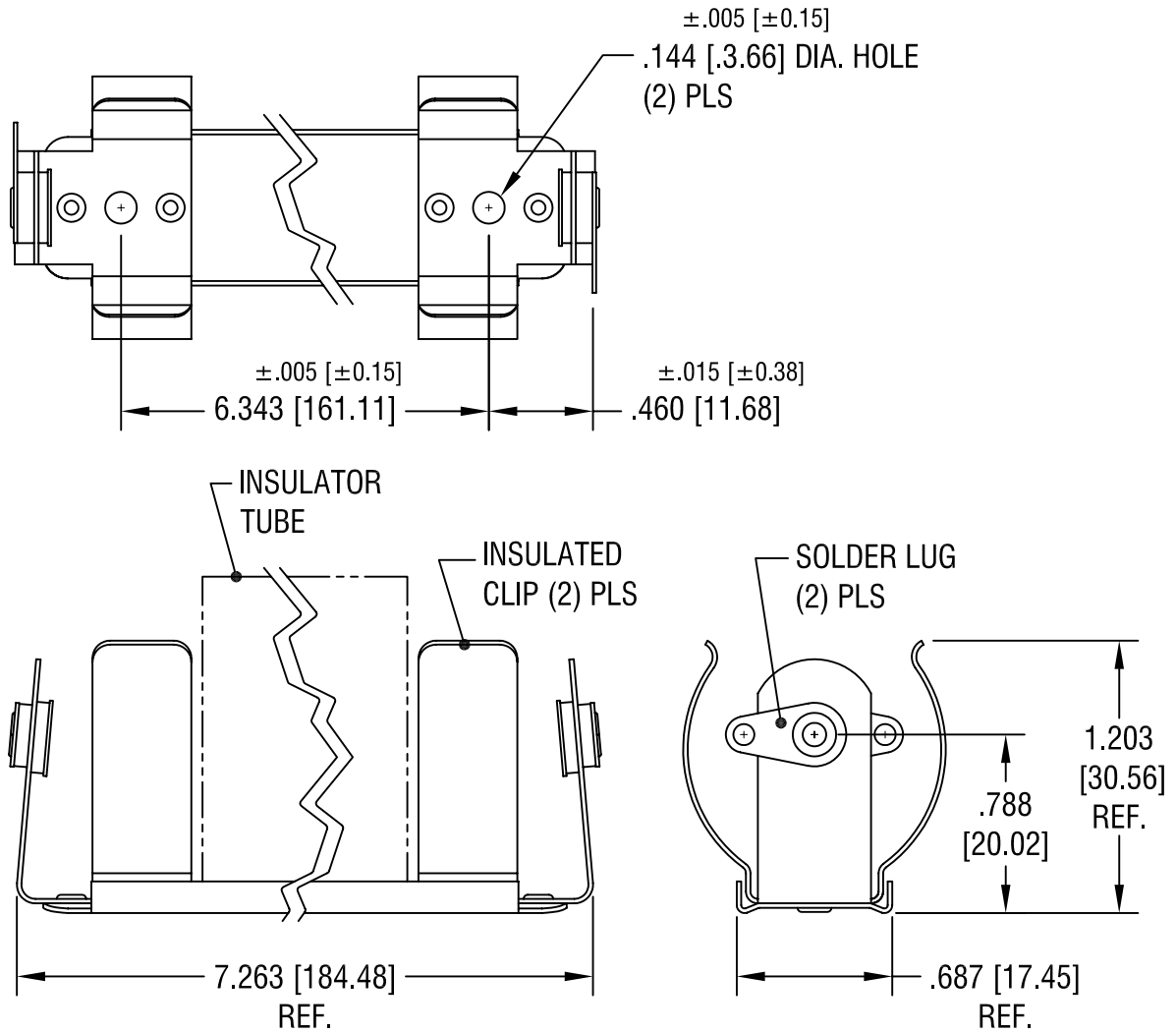

NOTES:

- 1. BASE: MAT'L - STAINLESS STEEL
- CLIP: MAT'L - SPRING STEEL
- FINISH - NICKEL PLATE
- LUG: MAT'L - BRASS
- FINISH - TIN PLATE
- TUBE: MAT'L - WOUND PAPER, BLACK

KEYSTONE ELECTRONICS CORP.			
ASTORIA, N.Y. 11105-2017			
PART NAME			
INSULATED BATTERY HOLDER (3) 'D'			
MATERIAL			
AS NOTED			
FINISH		DRN BY	DATE
AS NOTED		BOONE	4.21.04
		APP'D	SCALE
		LN	1.2X
TOLERANCES	INCH [MM]	CODE	DWG NO.
DECIMAL	±.010 [±0.25]	C	2199
ANGULAR	± 1°		
UNLESS OTHERWISE SPECIFIED			

DATE	DESCRIPTION	REV.