

NOTES:

22-922-0000-30

MATERIALS: SST. CORROSION-RESISTANT, NON MAGNETIC 303, PER ASTM A484 AND A582. BERYLLIUM COPPER PER ASTM-B-196, QQ-C-530 REXOLITE 1422

FINISH: CENTER CONDUCTORS AND SOLDER COMPONENTS SHALL BE PLATED PER MIL-G-45204 TYPE II, CLASS 1 OVER NICKEL PLATE PER QQ-N-290.
BODY AND BODY COMPONENTS SHALL BE PASSIVATED PER ASTM A380.

FREQUENCY: DC-34.5 GHz
VSWR: 1.25 TO 34.5 GHz
INSERTION LOSS: $.05\sqrt{\text{Frequency}}$

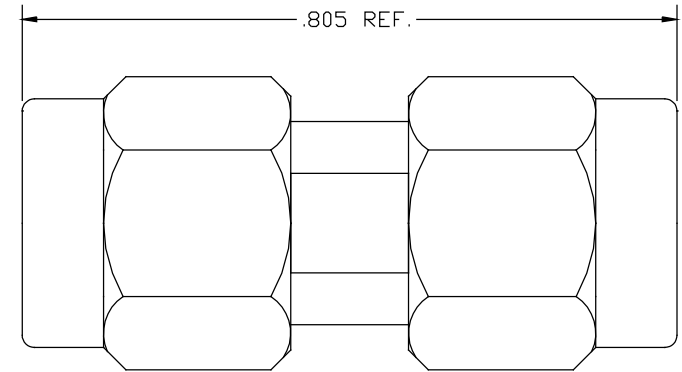

LTR	DESCRIPTION	DATE	APPR.	DRAWN LMW	CHECKED	USED ON	 SRI CONNECTOR GAGE CO. 3950 DOW ROAD MELBOURNE FL. 32934	
-	REL	05/03		APPR.	SCALE	22-922-0000-30	TITLE 3.5mm PLUG TO 3.5mm PLUG	
				UNLESS OTHERWISE SPECIFIED: 1. REMOVE ALL BURRS 2. BREAK ALL CORNERS & EDGES .005 R. MAX 3. CHAMFER 1st & LAST THREADS 45° 4. SURFACE FINISHED 32/ UNLESS OTHERWISE SPECIFIED. 5. DIAMETERS ON COMMON CENTERS TO BE CONCENTRIC WITHIN .002 T.I.R. 6. ALL DIMENSIONS ARE AFTER PLATING.				
				DIMENSIONS ARE IN INCHES TOLERANCES			FINISH	
				DECIMALS .X ±.030 .XX ±.010 .XXX +.005	FRACTIONAL ± 1/64	ANGULAR .X° ±1°0' .X°X' ±15'	SIZE	FSCM NO.
						A		OHMO1
							SHEET	DWG. NO.
							1	22-922-0000-30