

22-922-2010-30

NOTES:

- Materials:** SST. corrosion-resistant, Non Magnetic 303, per ASTM A484 and A582. Beryllium Copper per ASTM-B-196, QQ-C-530 Rexolite 1422
- Finish:** Center Conductors and solder components shall be plated per MIL-G-45204 Type II, Class 1 over Nickel plate per QQ-N-290. Body and Body components shall be passivated per ASTM A380.
- Frequency:** DC-34.5 GHz
- VSWR:** 1.25 TO 34.5 GHz
- Insertion Loss:** $.05\sqrt{\text{Frequency}}$

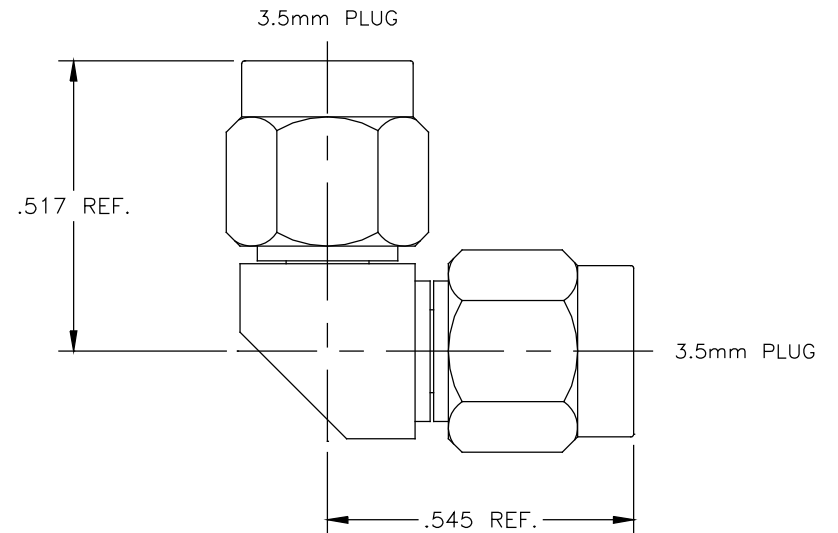

LTR	DESCRIPTION	DATE	APPR.	DRAWN <i>FAA</i>	CHECKED	USED ON	SRI CONNECTOR GAGE CO. 3950 DOW ROAD MELBOURNE FL. 32934			
-	REL	01/14		APPR.	SCALE	22-922-2010-30	TITLE 3.5mm PLUG TO 3.5mm PLUG, RIGHT ANGLE ADAPTER			
				UNLESS OTHERWISE SPECIFIED: 1. REMOVE ALL BURRS 2. BREAK ALL CORNERS & EDGES .005 R. MAX 3. CHAMFER 1st & LAST THREADS 45° 4. SURFACE ROUGHNESS 63 MIL-STD-10 5. DIAMETERS ON COMMON CENTERS TO BE CONCENTRIC WITHIN T.I.R. 6. ALL DIMENSIONS ARE AFTER PLATING			MATERIAL			
				DIMENSIONS ARE IN INCHES TOLERANCES			FINISH			
				DECIMALS .X +.030 .XX +.015 .XXX +.005	FRACTIONAL ± 1/64	ANGULAR .X° ± 90' .X°X' ± 15'	SIZE	FSCM NO.	SHEET	DWG. NO.
						A	OHMO1	1	22-922-2010-30	