

THIS DRAWING IS UNPUBLISHED.

RELEASED FOR PUBLICATION

20

© COPYRIGHT 20 BY -

ALL RIGHTS RESERVED.

REVISIONS

P	LTR	DESCRIPTION	DATE	DWN	APVD
B2		ECR-17-002648	24FEB2017	RK	MvE
C		REVISED PER ECR-17-005513	13APR2017	SK	MvE
D		REVISED PER ECR-18-017701	15NOV2018	GCM	DD
D1		REVISED PER ECR-19-000064	04JAN2019	SR	DD

NOTES:

- MATERIALS:
HOUSING: GLASS FILLED PBT
HALOGEN FREE FLAME RETARDANT,
COLOR : NATURAL/WHITE
CONTACTS: SILVER PLATED COPPER ALLOY
- FOR SOLID AND STRANDED WIRE AWG 22-18
- COMPLIES WITH DIRECTIVE 2002/95/EC (ROHS)
- M3 SCREW TO BE USED FOR MOUNTING
- DATE CODE YY-WW-D ANY WHERE EXCEPT OVER LOGO OR +/- SIGN.
- FOR COB-TO-HOLDER CROSS REFERENCE, REFER TO APPLICATION SPECIFICATION 114-32208.

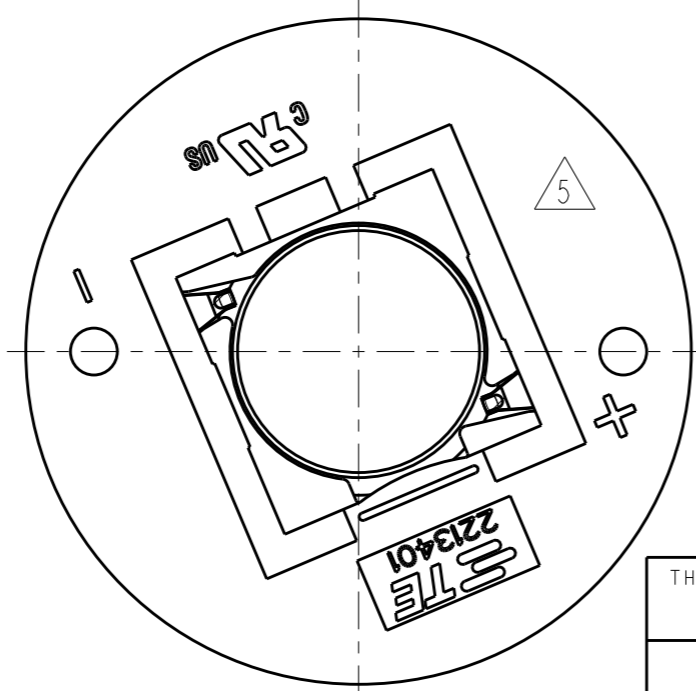
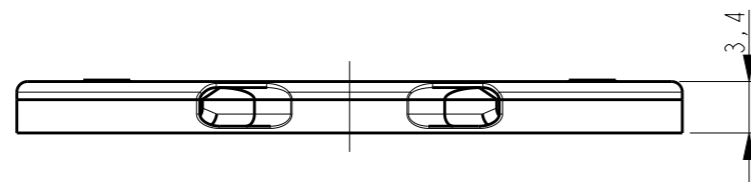
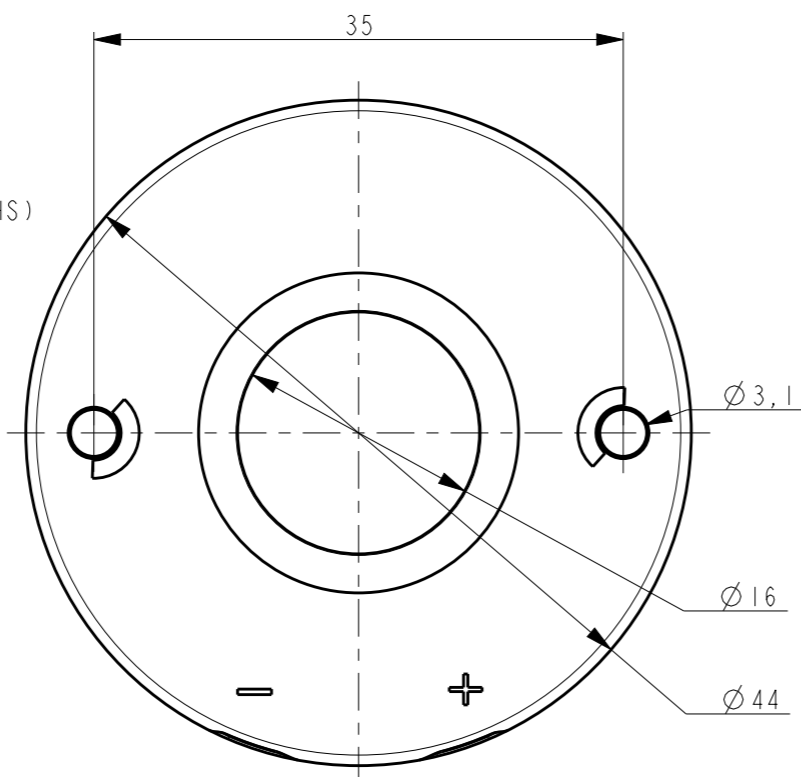

M3 SCREW HOLES

WIRE ENTRANCE

SCALE 3:2

LED CLAMPING FEATURE

LED PRESSURE CONTACTS

2213401-1 AS SHOWN
LUMAWISE LED HOLDER Z50 LOW PROFILE

LUMAWISE LED HOLDER Z50 STANDARD PROFILE 1818	2213401-2
LUMAWISE LED HOLDER Z50 LOW PROFILE 1818	2213401-1
DESCRIPTION	PART NO

THIS DRAWING IS A CONTROLLED DOCUMENT.

DIMENSIONS:	TOLERANCES UNLESS OTHERWISE SPECIFIED:
mm	
	0 PLC ±-
	1 PLC ±-
	2 PLC ±-
	3 PLC ±-
	4 PLC ±-
	ANGLES ±2°
MATERIAL	FINISH
-	-
-	-

DWN	28OCT2013
YASHKUMAR	
CHK	28OCT2013
M.V.ESSEN	
APVD	29OCT2013
O.I.FLJNSF	
PRODUCT SPEC	108-133008
APPLICATION SPEC	114-32048
WEIGHT	-
CUSTOMER DRAWING	

STE TE Connectivity			
NAME LUMAWISE LED HOLDER Z50 1818			
SIZE	CAGE CODE	DRAWING NO	RESTRICTED TO
A3	-	C-2213401	
SCALE		SHEET	REV
2:1		1 OF 3	D1

THIS DRAWING IS UNPUBLISHED.

RELEASED FOR PUBLICATION

20

© COPYRIGHT 20 BY - ALL RIGHTS RESERVED.

REVISIONS

P	LTR	DESCRIPTION	DATE	DWN	APVD
-		SEE SHEET 1	-	-	-

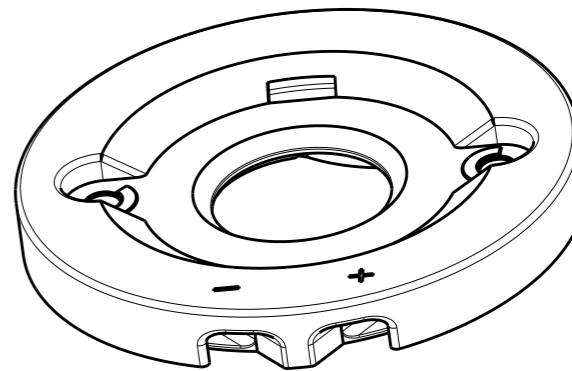
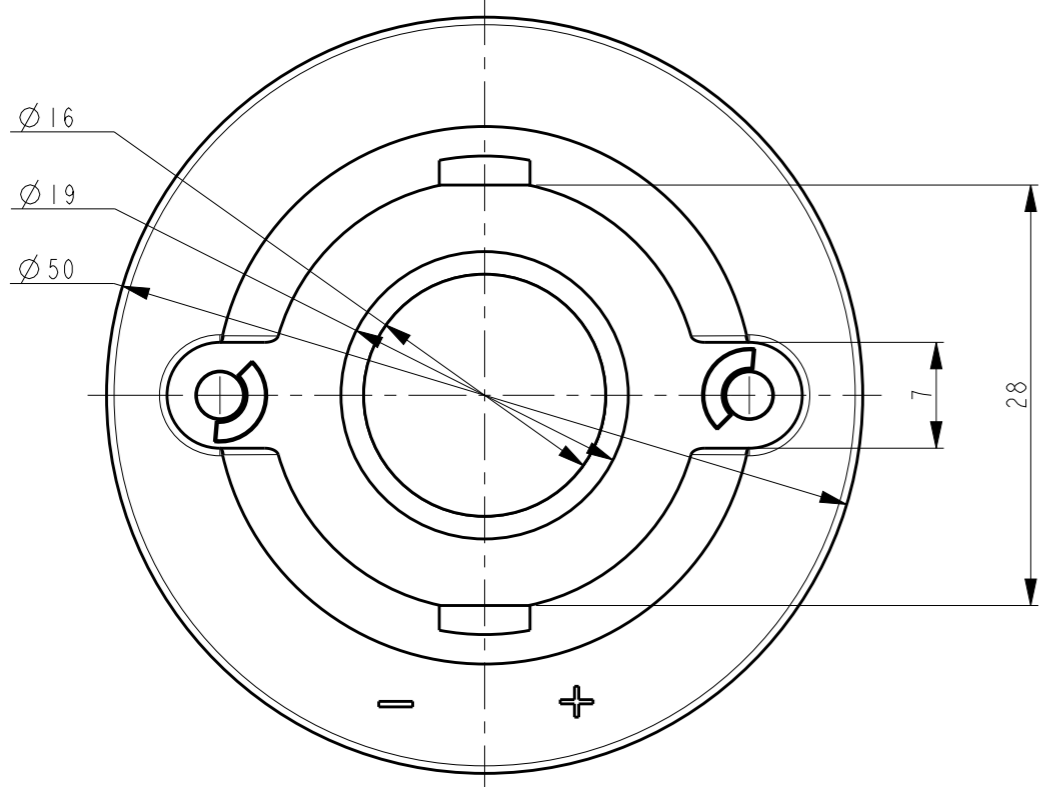

SCALE 3:2

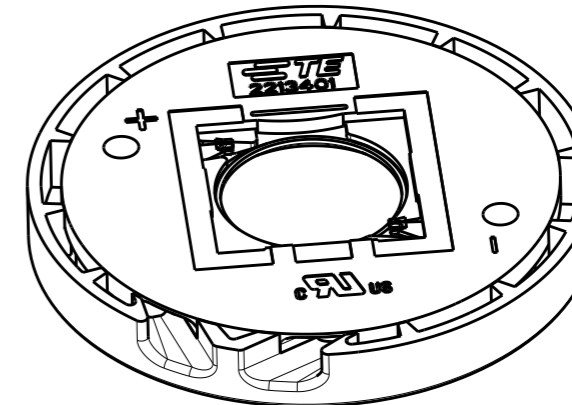

2213401-2 AS SHOWN
LUMAWISE LED HOLDER Z50 STANDARD PROFILE

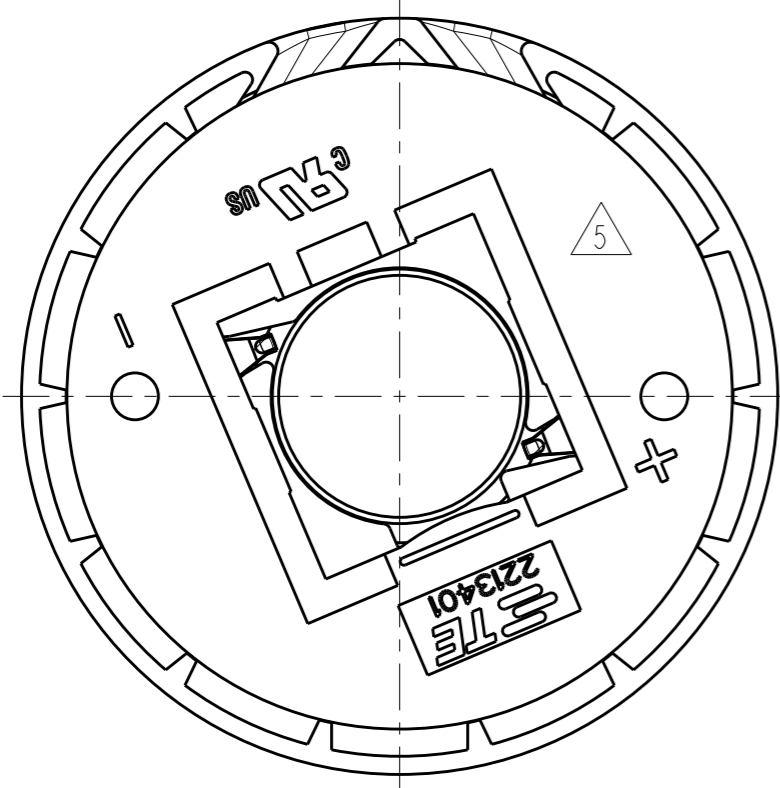
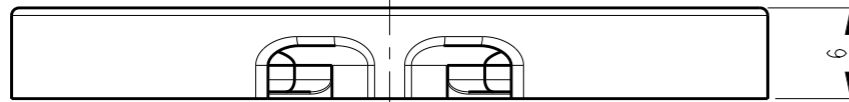

THIS DRAWING IS A CONTROLLED DOCUMENT.

DIMENSIONS: mm	TOLERANCES UNLESS OTHERWISE SPECIFIED:
	0 PLC ±-
	1 PLC ±-
	2 PLC ±-
	3 PLC ±-
	4 PLC ±-
	ANGLES ±2°
MATERIAL	FINISH
-	-
-	-

DWN	28OCT2013
YASHKUMAR	
CHK	28OCT2013
M.V.ESSEN	
APVD	29OCT2013
O.I.FLJNSE	
PRODUCT SPEC	108-133008
APPLICATION SPEC	114-32048
WEIGHT	-
CUSTOMER DRAWING	

TE Connectivity		NAME		RESTRICTED TO
		LUMAWISE LED HOLDER Z50 1818		
SIZE	CAGE CODE	DRAWING NO		
A3	-	C-2213401		
SCALE		SHEET	OF	REV
2:1		2	3	DI