

THIS DRAWING IS UNPUBLISHED. RELEASED FOR PUBLICATION 20
 © COPYRIGHT 20 BY - ALL RIGHTS RESERVED.

- NOTES:
- 1 MATERIALS AND FINISH:
 -MODULE HOUSING: PBT, COLOR: GREY
 -CONTACTS: BRASS, FINISH: Sn
 -O-RING: SILICON RUBBER
 2. MUST COMPLY WITH DIRECTIVE 2002/95/EC (ROHS)
 - 3 LOCATION OF FLAT ON RECEPTACLE (TE P/N 2213858-1)
 THREAD SECTION IN FULL MATED POSITION
 4. COMPATIBLE DOME IS 2328823-X.

REVISIONS				
P	LTR	DESCRIPTION	DATE	APVD
A		REVISED PER ECR-18-017023	05NOV2018	SR DD
A1		REVISED PER ECR-18-017999	22NOV2018	SR DD
A2		REVISED PER ECR-19-017457	12NOV2019	SB DD

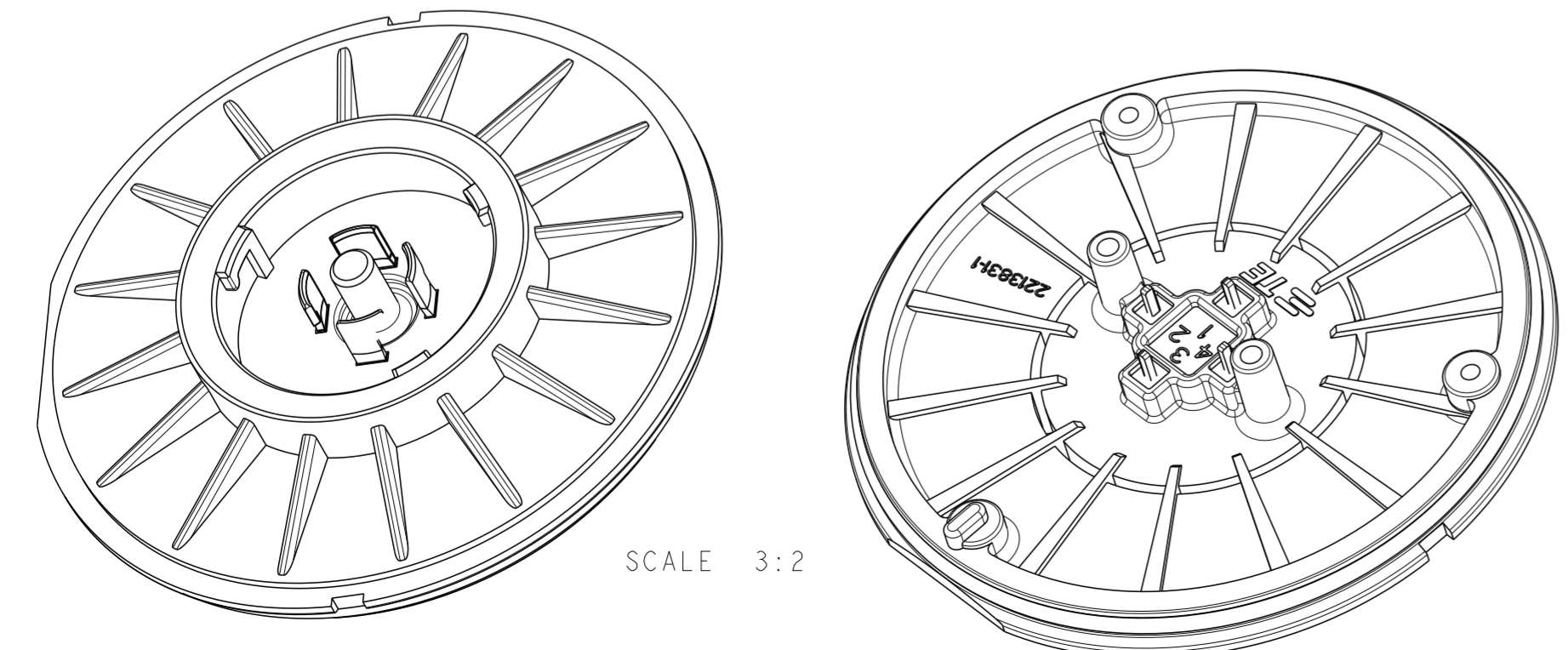
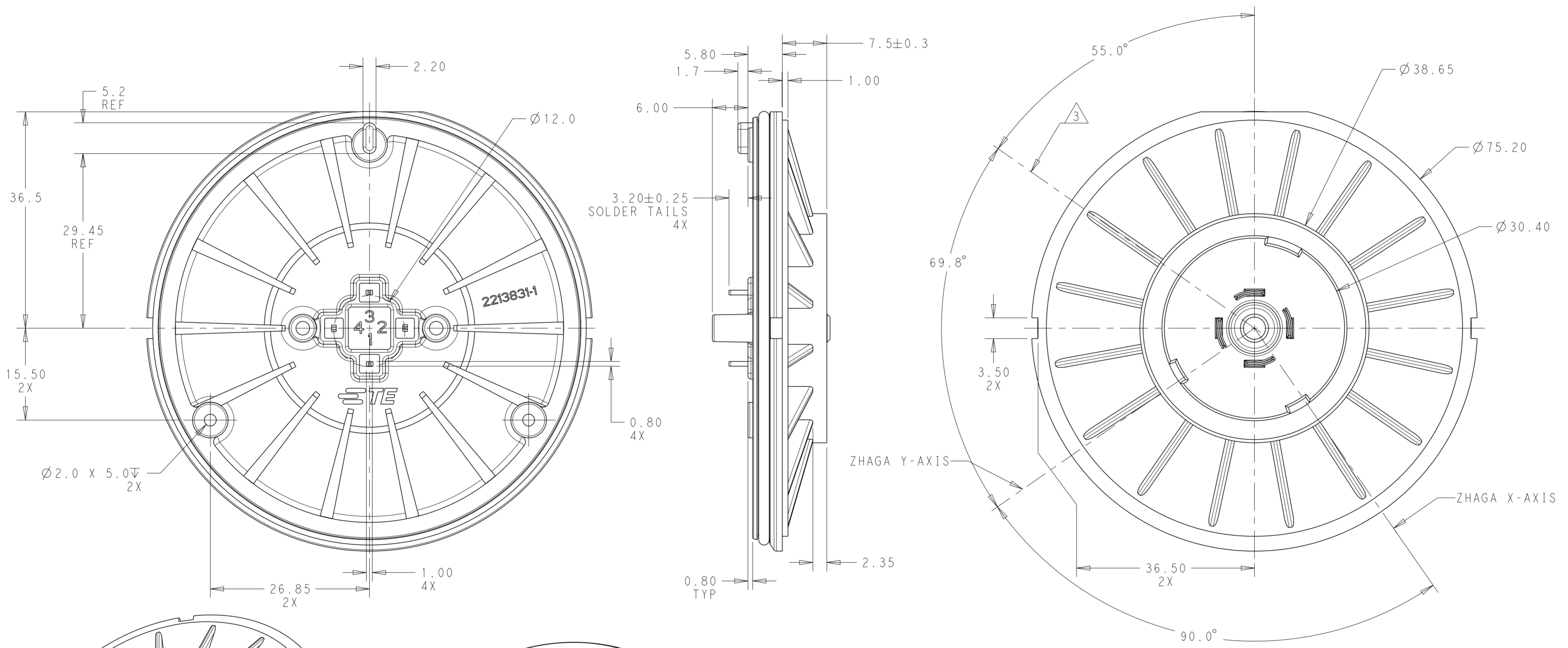

2213831-1 SHOWN

-	2213831-3
-	2213831-2
-	2213831-1
NOTES	PART NO.

THIS DRAWING IS A CONTROLLED DOCUMENT.		DWN C. DAILY	05APR2016	TE Connectivity	
		CHK E. HOWARD	05APR2016		
DIMENSIONS:		TOLERANCES UNLESS OTHERWISE SPECIFIED:		NAME	
mm		0 PLC ±		MODULE BASE ASSEMBLY,	
		1 PLC ±0.2		LUMAWISE ENDURANCE S	
		2 PLC ±0.15		80mm DIAMETER	
		3 PLC ±		SIZE	
		4 PLC ±		A2	
		ANGLES ±1		CAGE CODE	
		FINISH		DRAWING NO	
MATERIAL		-		G-2213831	
SEE NOTES		-		RESTRICTED TO	
		CUSTOMER DRAWING		SCALE 2:1 SHEET 1 OF 3 REV A2	

THIS DRAWING IS UNPUBLISHED. RELEASED FOR PUBLICATION 20
 © COPYRIGHT 20 BY - ALL RIGHTS RESERVED.

REVISIONS				
P	LTR	DESCRIPTION	DATE	APVD
-		SEE SHEET 1	-	-

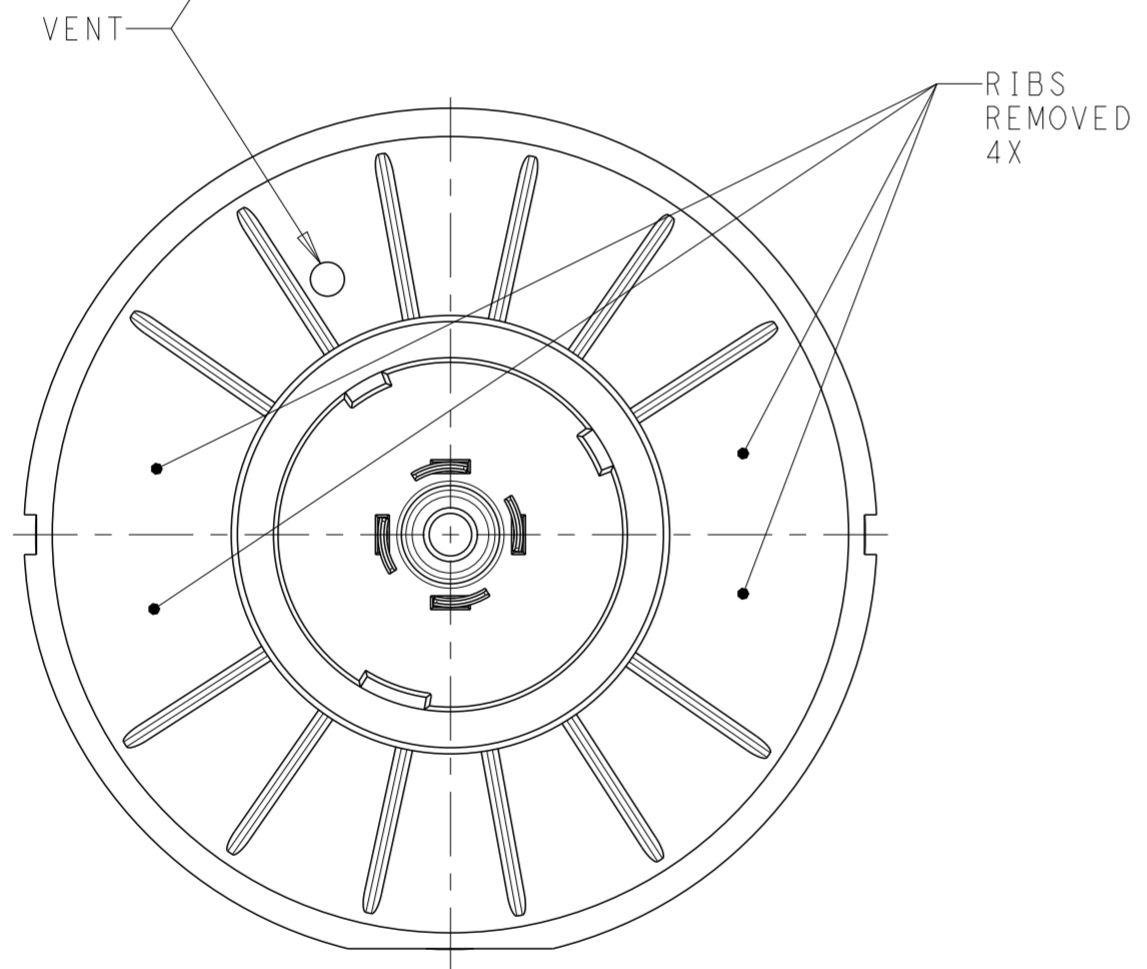
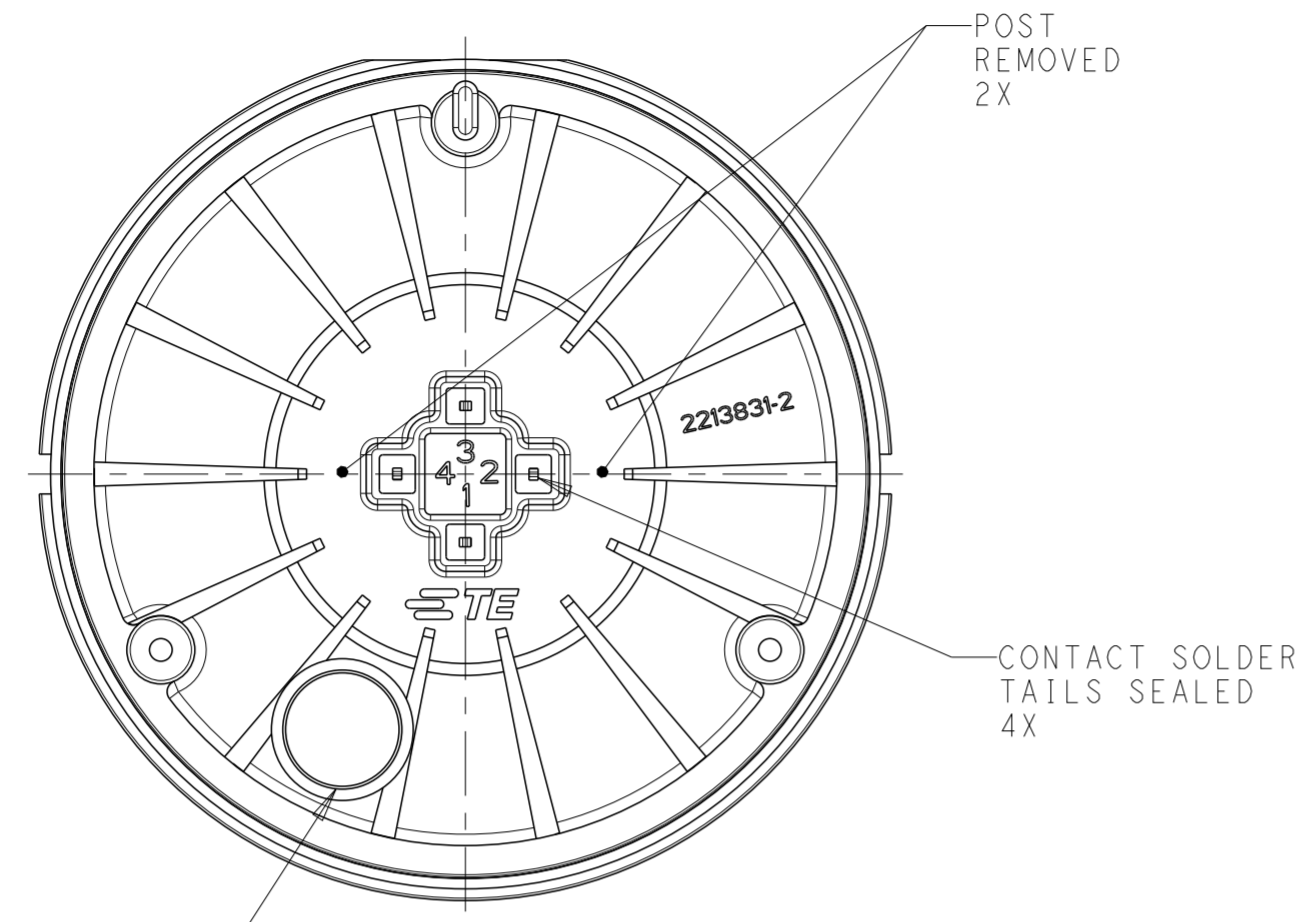

2213831-2 SHOWN
 SAME AS
 2213831-1 EXCEPT AS SHOWN

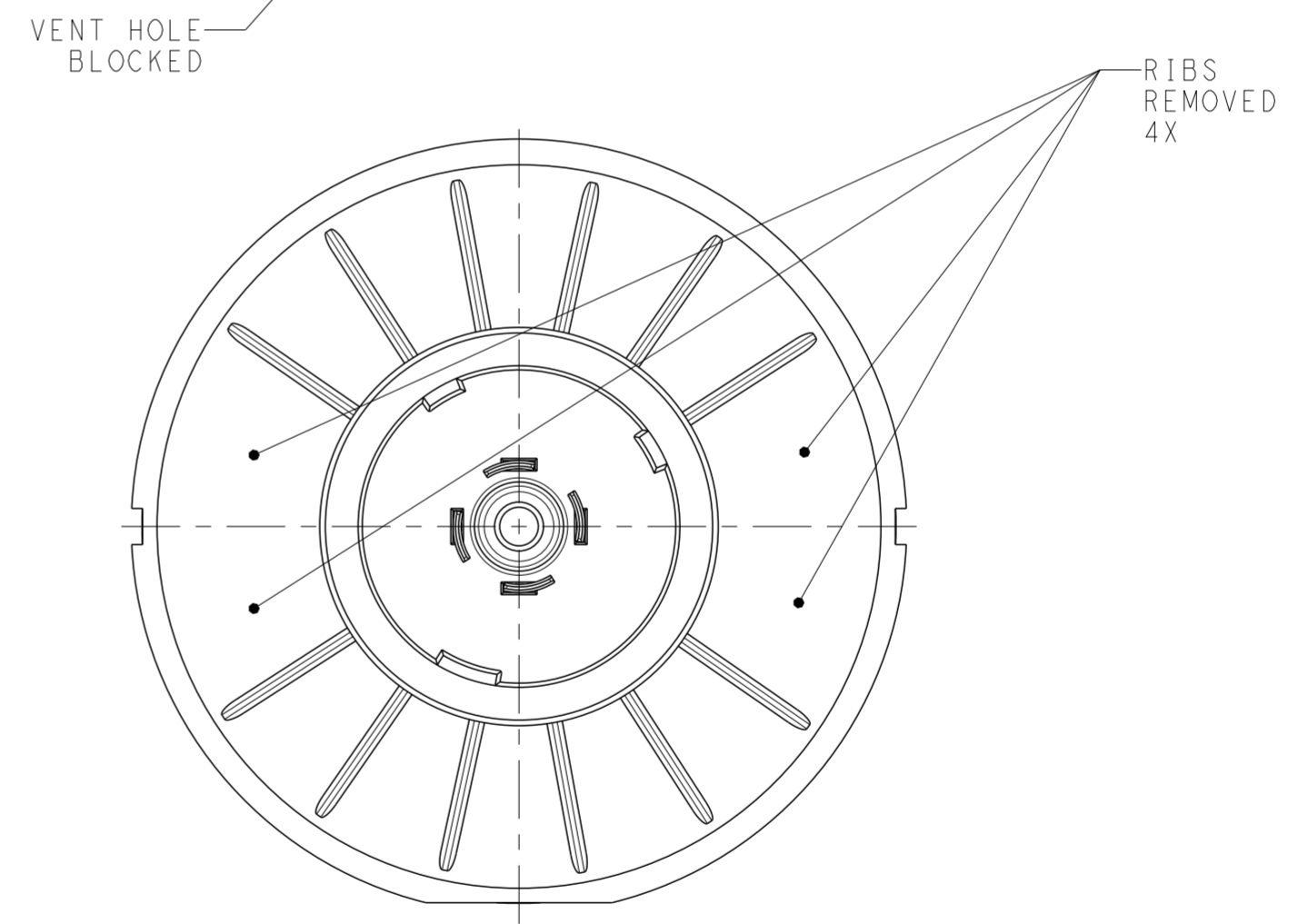
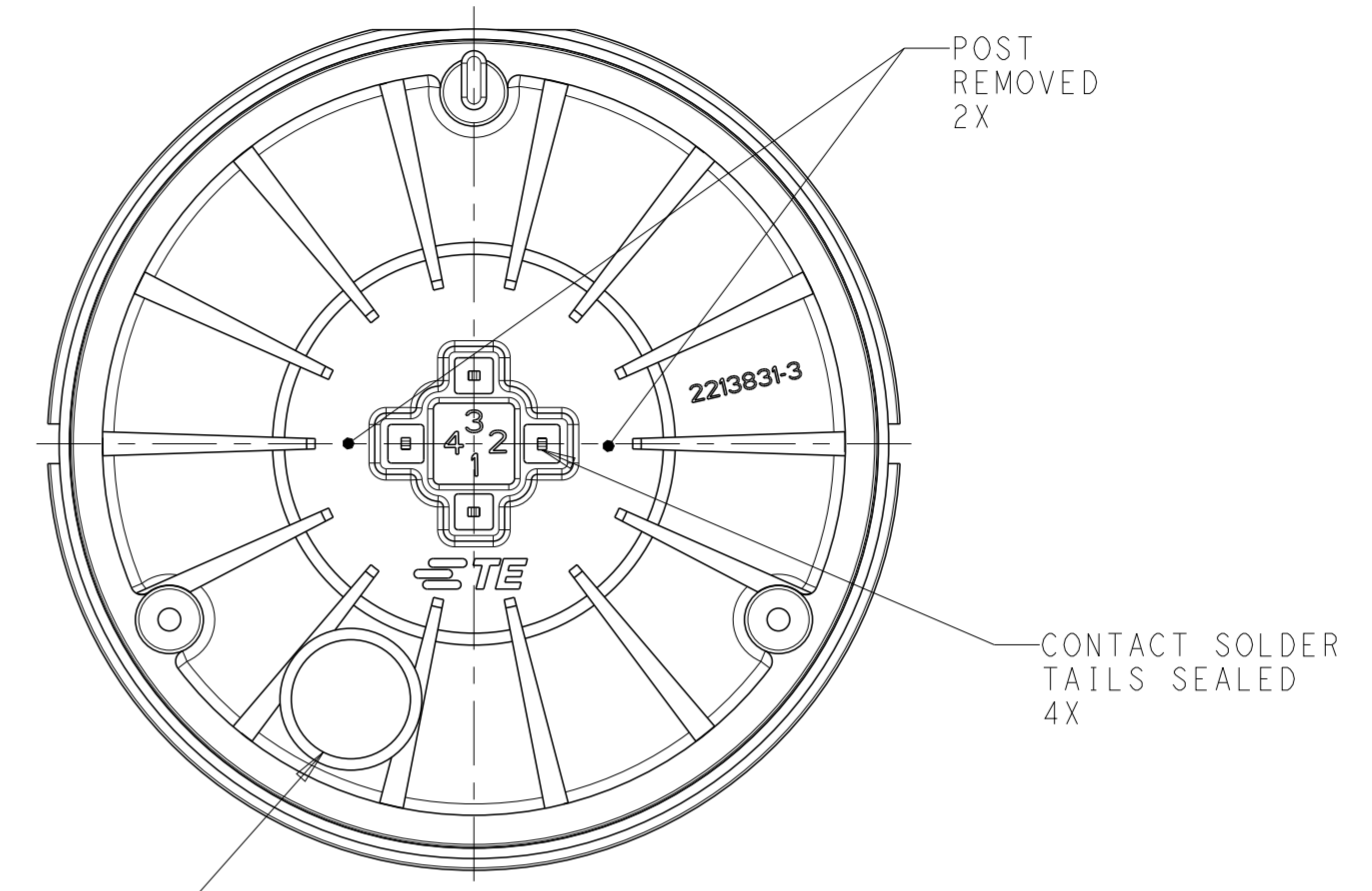

2213831-3 SHOWN
 SAME AS
 2213831-1 EXCEPT AS SHOWN

THIS DRAWING IS A CONTROLLED DOCUMENT.		DWN C. DAILY 05APR2016	STE TE Connectivity	
		CHK E. HOWARD 05APR2016		
DIMENSIONS:	TOLERANCES UNLESS OTHERWISE SPECIFIED:	APVD -	NAME MODULE BASE ASSEMBLY, LUMAWISE ENDURANCE S 80mm DIAMETER	
mm	0 PLC ± 1 PLC ±0.2 2 PLC ±0.15 3 PLC ± 4 PLC ±	PRODUCT SPEC 108-133073	SIZE A2	CAGE CODE -
MATERIAL - SEE NOTES	ANGLES ±1 FINISH -	APPLICATION SPEC 114-133074	DRAWING NO G-2213831	RESTRICTED TO -
		WEIGHT -	SCALE 2:1	SHEET 2 OF 3
		CUSTOMER DRAWING	REV A2	