

THIS DRAWING IS UNPUBLISHED. RELEASED FOR PUBLICATION 20
 © COPYRIGHT 20 BY - ALL RIGHTS RESERVED.

REVISIONS					
P	LTR	DESCRIPTION	DATE	DWN	APVD
A3		REVISED PER ECR-19-003969	12MAR2019	JS	DD
A4		REVISED PER ECR-19-008871	13JUN2019	SR	DD
A5		REVISED PER ECR-19-009651	12JUL2019	SR	DD
B		REVISED PER ECR-19-017691	19NOV2019	SB	DD

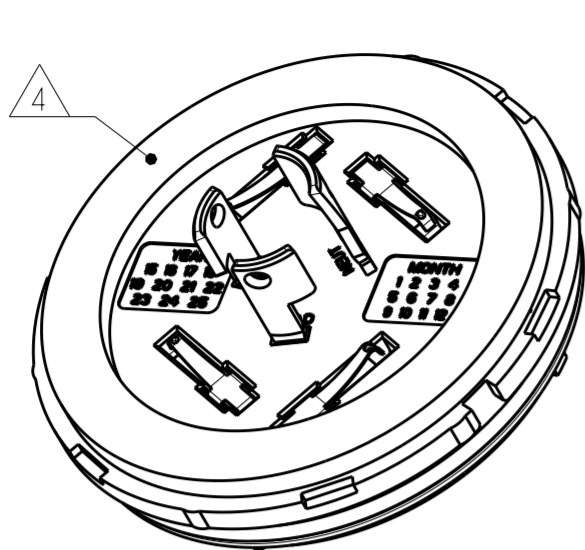

2213871-1 AND 2213871-2 SHOWN

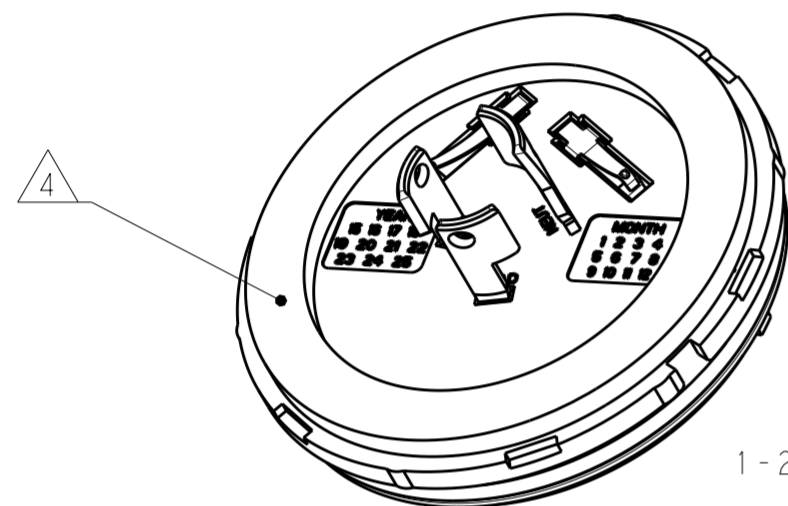
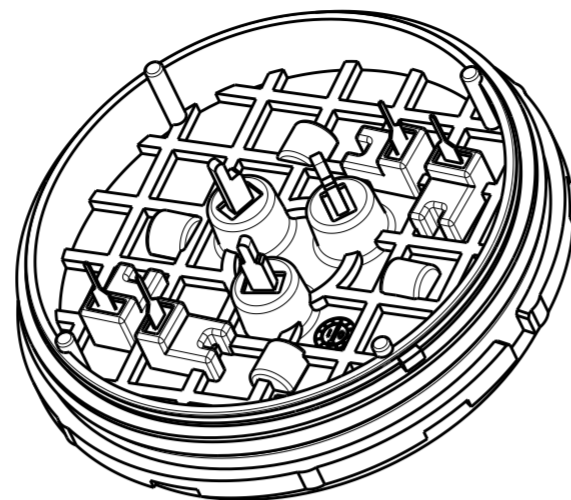

1-2213871-1 AND 1-2213871-2 SHOWN

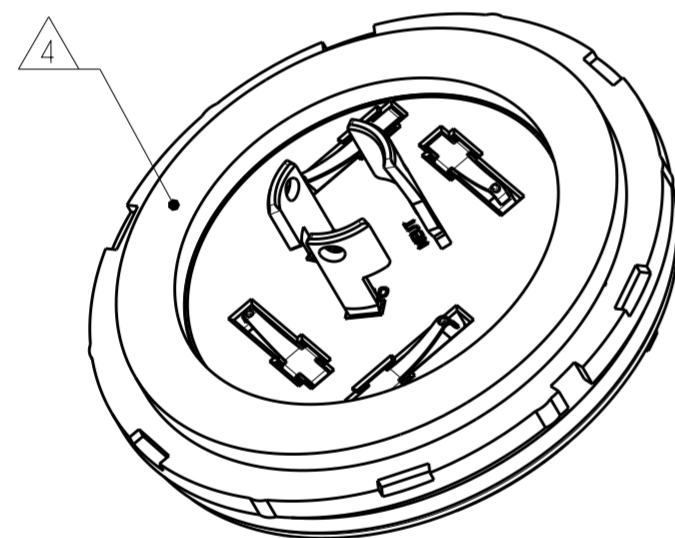
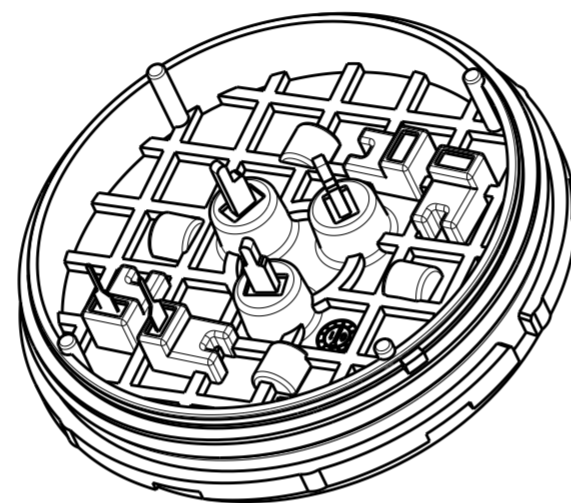

2213871-3 SHOWN

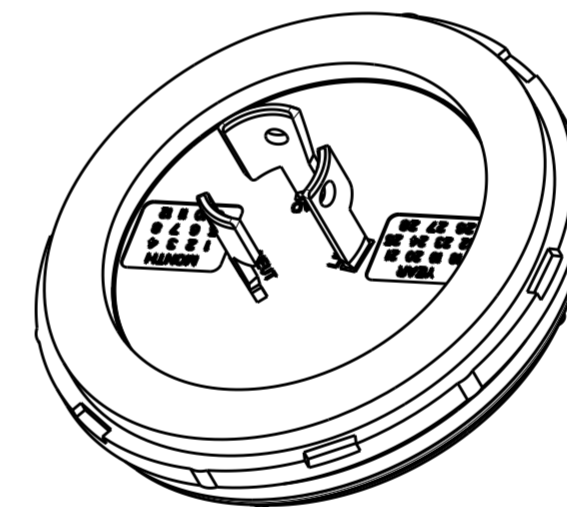
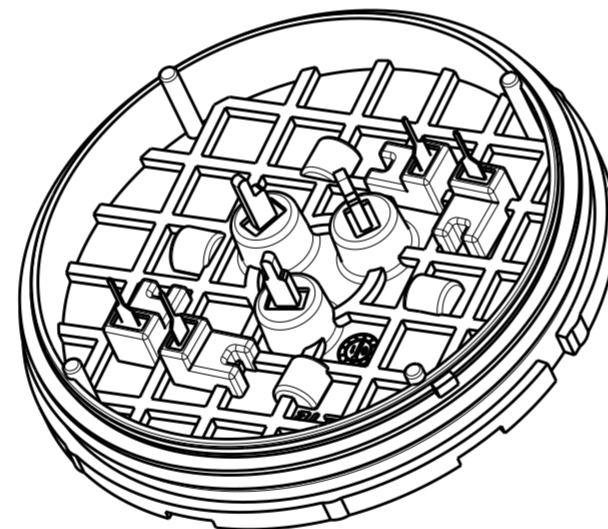

1-2213871-3 SHOWN

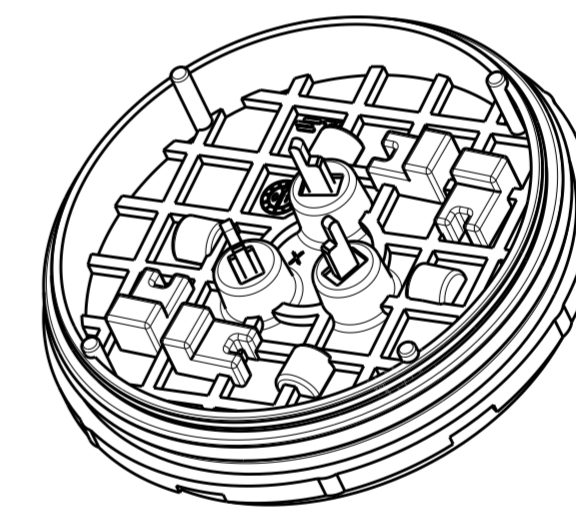

- 1 MATERIALS:
 HOUSING: PBT
 DIMMING CONTACTS (QTY. 4): COPPER ALLOY
 LINE VOLTAGE CONTACTS (QTY. 3): COPPER ALLOY
 GASKET: VINYL/NITRILE FOAM
 O-RING: SILICONE RUBBER
- 2 FINISH:
 DIMMING CONTACTS: NICKEL UNDERPLATE ENTIRE
 CONTACT 0.127 µm MIN THICK. SELECTIVE GOLD PLATE CONTACT
 MATING AREA (MATING FACE SIDE ONLY) 0.76 µm MIN THICK.
 MATTE TIN PLATE TAB ON BOTH SIDES 0.30 µm MIN THICK.
 LINE VOLTAGE CONTACTS: MATTE TIN PLATE
- 3 MATING INTERFACE PER ANSI C136.41-2013.
- 4 ADHESIVE BACKED GASKET SUPPLIED BUT NOT INSTALLED.
- 5 ADDITIONAL COVERS AND SLEEVES OF VARIOUS HEIGHTS ARE AVAILABLE. CONTACT TE CONNECTIVITY FOR MORE OPTIONS.
- 6. NOTE DELETED.
- 7. THIS PRODUCT HAS NOT COMPLETED VALIDATION TESTING.

2213805-X	2213748-X	3	Ø77.00	Ø73.00	Ø64.50	Ø65.00	Ø66.75	Ø71.23	Ø72.00	Ø76.00	1-2213871-3
2213996-X	2306130-X	5	Ø82.24	Ø78.54	Ø69.80	Ø70.70	Ø72.25	Ø77.53	Ø77.74	Ø81.15	1-2213871-2
2213805-X	2213748-X	5	Ø77.00	Ø73.00	Ø64.50	Ø65.00	Ø66.75	Ø71.23	Ø72.00	Ø76.00	1-2213871-1
2213996-X	2306130-X	7	Ø82.24	Ø78.54	Ø69.80	Ø70.70	Ø72.25	Ø77.53	Ø77.74	Ø81.15	2213871-3
2213996-X	2306130-X	7	Ø82.24	Ø78.54	Ø69.80	Ø70.70	Ø72.25	Ø77.53	Ø77.74	Ø81.15	2213871-2
2213805-X	2213748-X	7	Ø77.00	Ø73.00	Ø64.50	Ø65.00	Ø66.75	Ø71.23	Ø72.00	Ø76.00	2213871-1
REPRESENTATIVE SLEEVE P/N 5	REPRESENTATIVE COVER P/N 5	CONTACT POSITIONS	DIM Y	DIM X	DIM P	DIM N	DIM M MAX WITH SLEEVE	DIM M MAX W/OUT SLEEVE	DIM F	DIM E	PART NO.

THIS DRAWING IS A CONTROLLED DOCUMENT.

DWN	J. SHAFFER	23MAR2016
CHK	E. HOWARD	23MAR2016
APVD	-	-
PRODUCT SPEC	108-32125	
APPLICATION SPEC	114-32159	
WEIGHT		
CUSTOMER DRAWING		

TE Connectivity

NAME: BASE ASSEMBLY, LIGHT CONTROLLER, SLEEVE COMPATIBLE

SIZE: A2 CAGE CODE: - DRAWING NO: C-2213871 RESTRICTED TO: -

SCALE: 2:1 SHEET: 1 OF 6 REV: B

THIS DRAWING IS UNPUBLISHED. RELEASED FOR PUBLICATION 20
 © COPYRIGHT 20 BY - ALL RIGHTS RESERVED.

REVISIONS				
P	LTR	DESCRIPTION	DATE	APVD
-	-	SEE SHEET 1	-	-

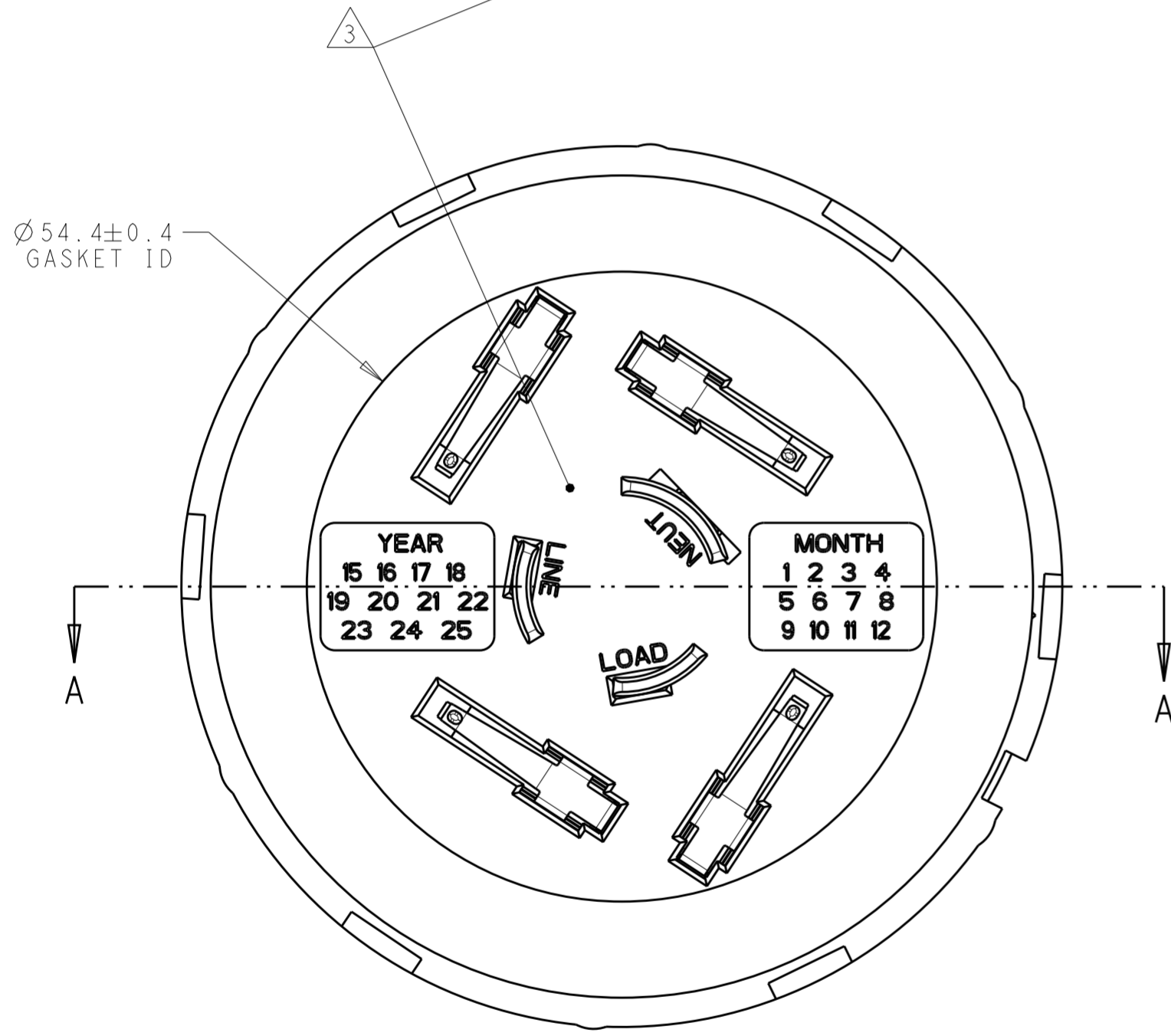
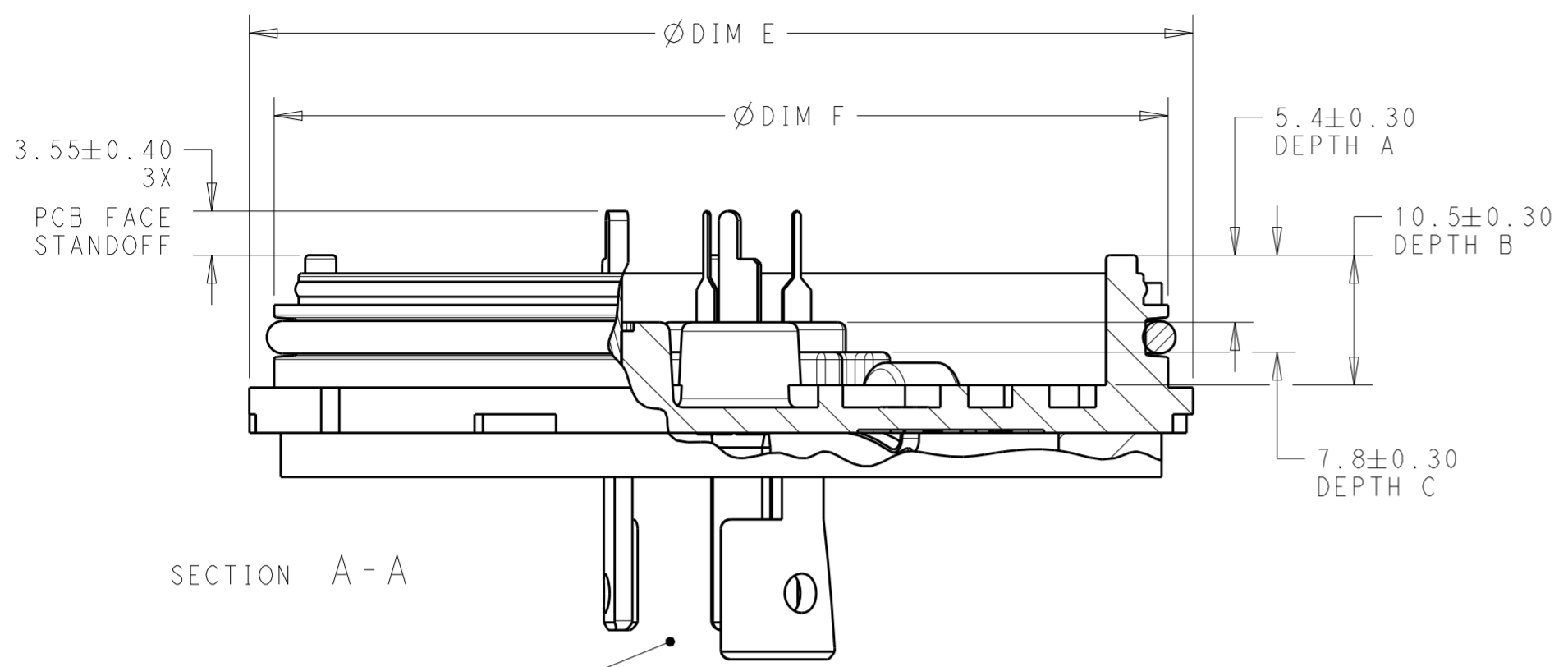

2213817-1 AND 2213871-2 SHOWN

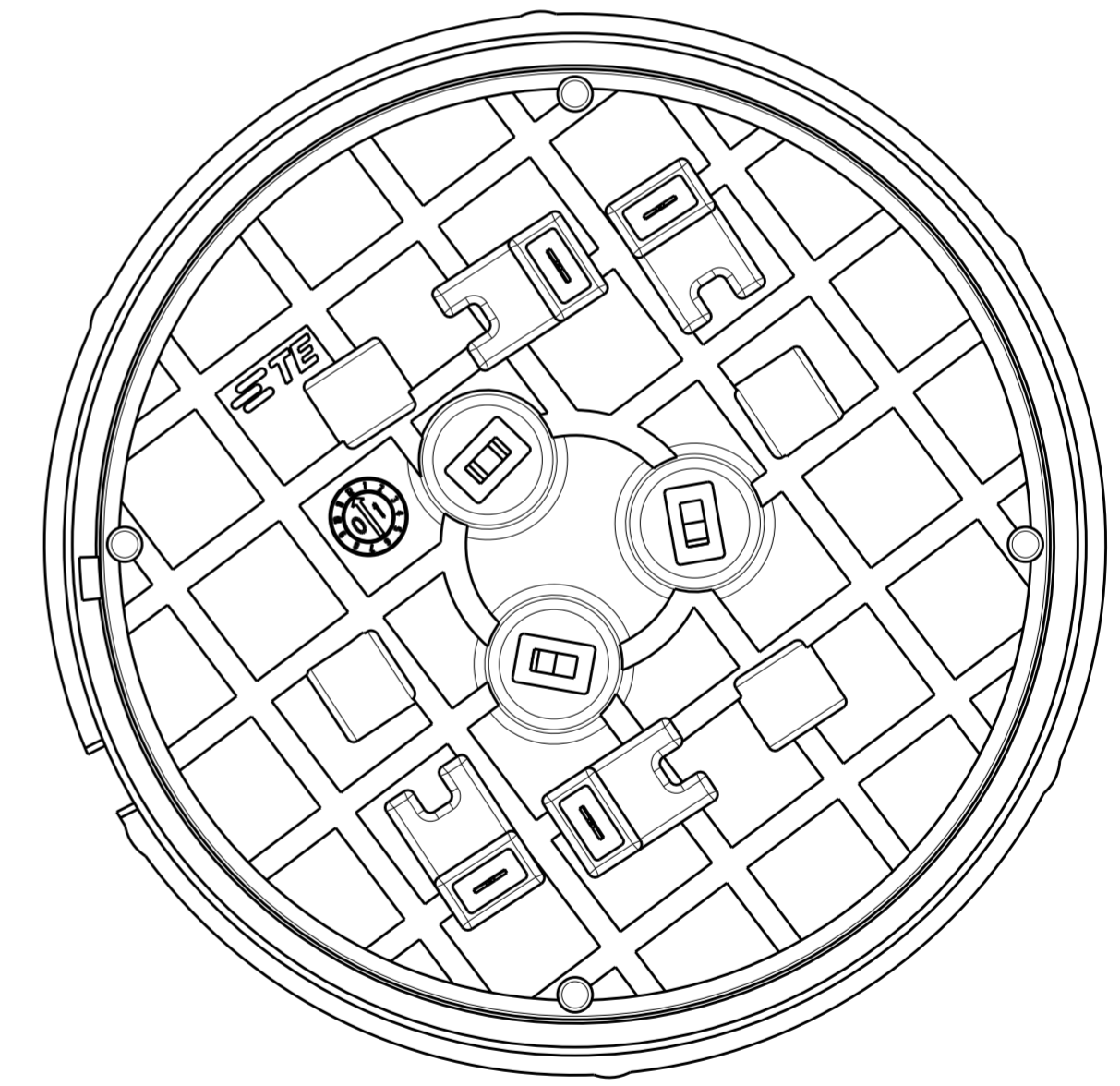
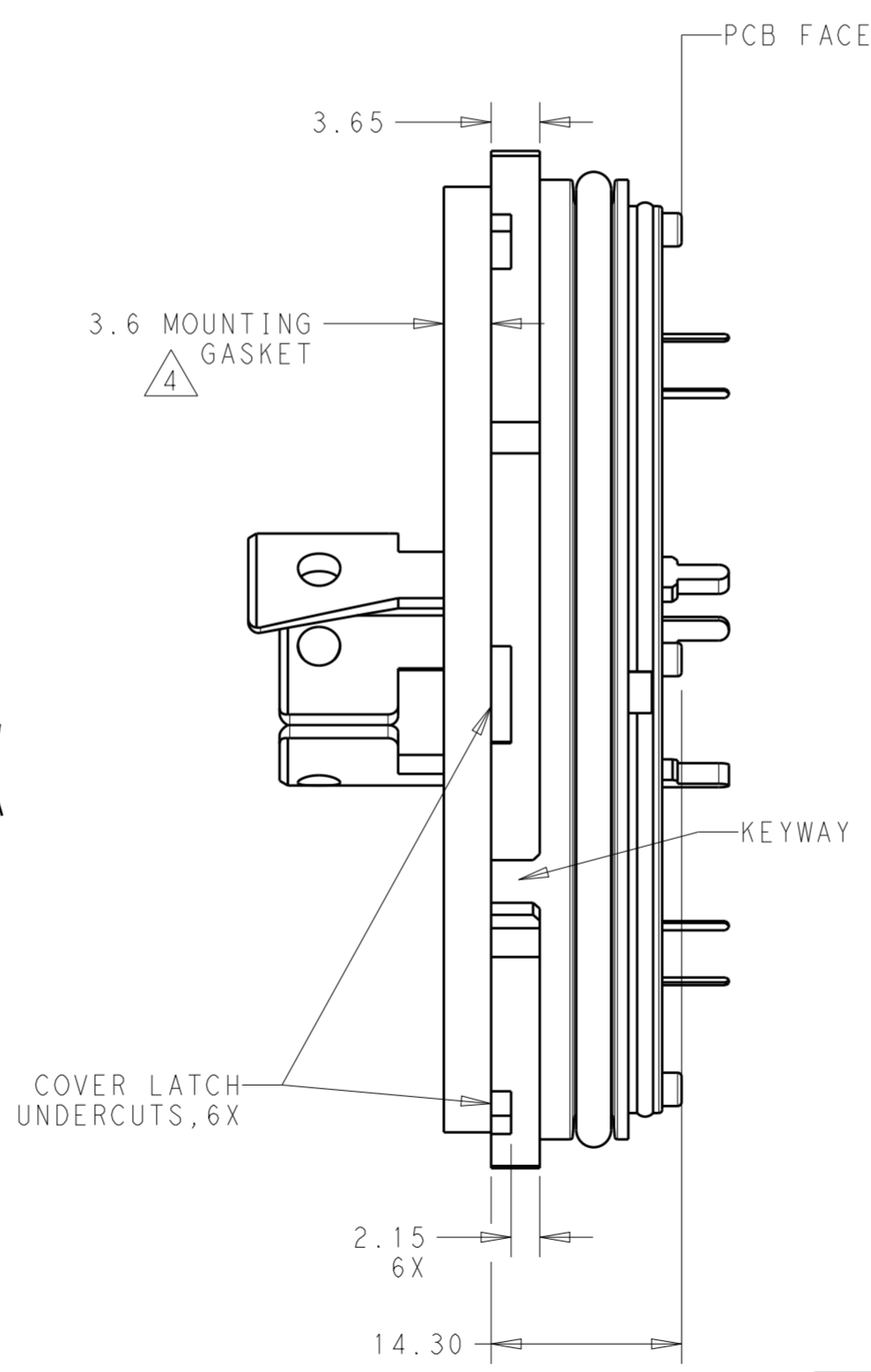

THIS DRAWING IS A CONTROLLED DOCUMENT.		DWN J. SHAFFER 23MAR2016	TE Connectivity	
		CHK E. HOWARD 23MAR2016		
DIMENSIONS:		APVD -	NAME BASE ASSEMBLY, LIGHT CONTROLLER, SLEEVE COMPATIBLE	
mm	TOLERANCES UNLESS OTHERWISE SPECIFIED:	PRODUCT SPEC 108-32125	SIZE A2	
	0 PLC ±	APPLICATION SPEC 114-32159	CAGE CODE -	DRAWING NO G-2213871
	1 PLC ±0.2	WEIGHT	RESTRICTED TO	
	2 PLC ±0.13	CUSTOMER DRAWING	SCALE 2:1	SHEET 2 OF 6
	3 PLC ±		REV B	
	4 PLC ±			
	ANGLES ±3°			
	FINISH			

THIS DRAWING IS UNPUBLISHED. RELEASED FOR PUBLICATION 20
 © COPYRIGHT 20 BY - ALL RIGHTS RESERVED.

REVISIONS				
P	LTR	DESCRIPTION	DATE	APVD
-	-	SEE SHEET 1	-	-

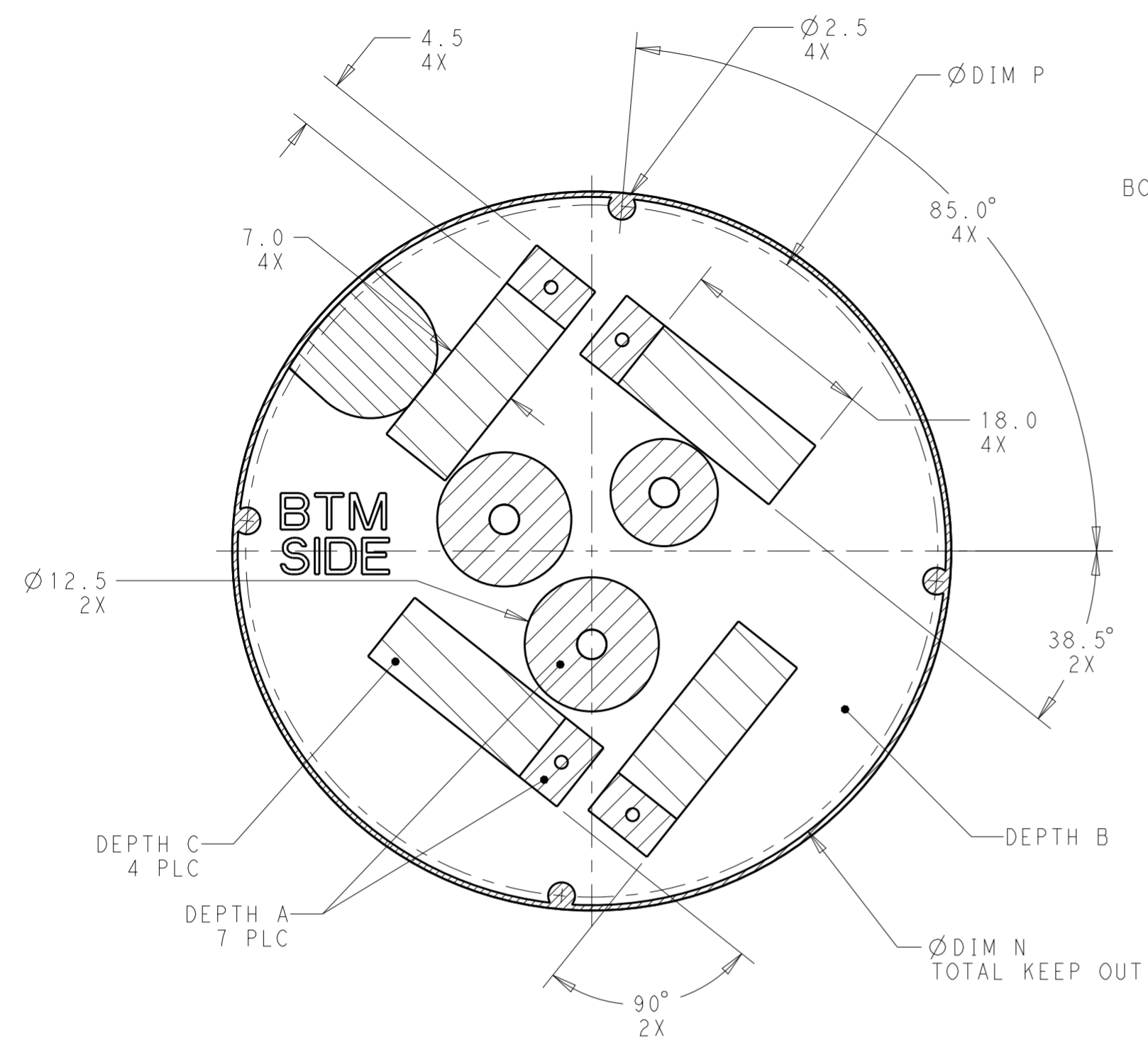

COMPONENT KEEP OUT AREAS
 2213871-1, 2213871-2 AND 2213871-3

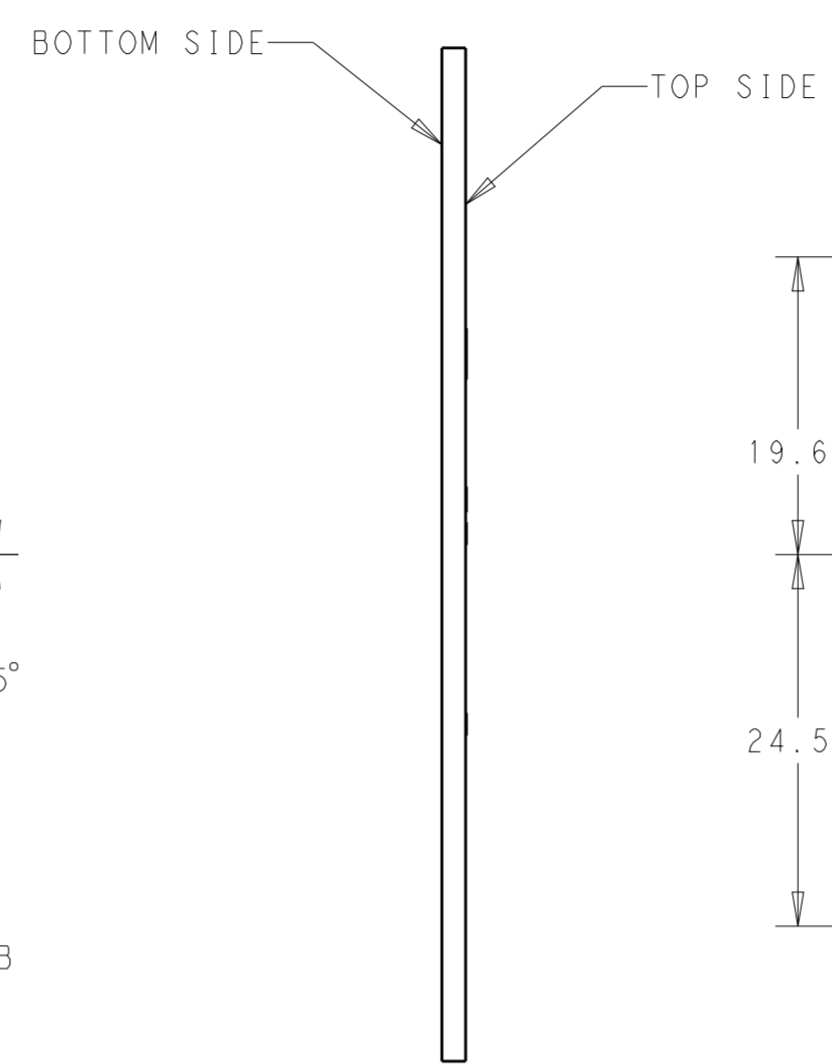

RECOMMENDED PCB
 SCALE 2:1

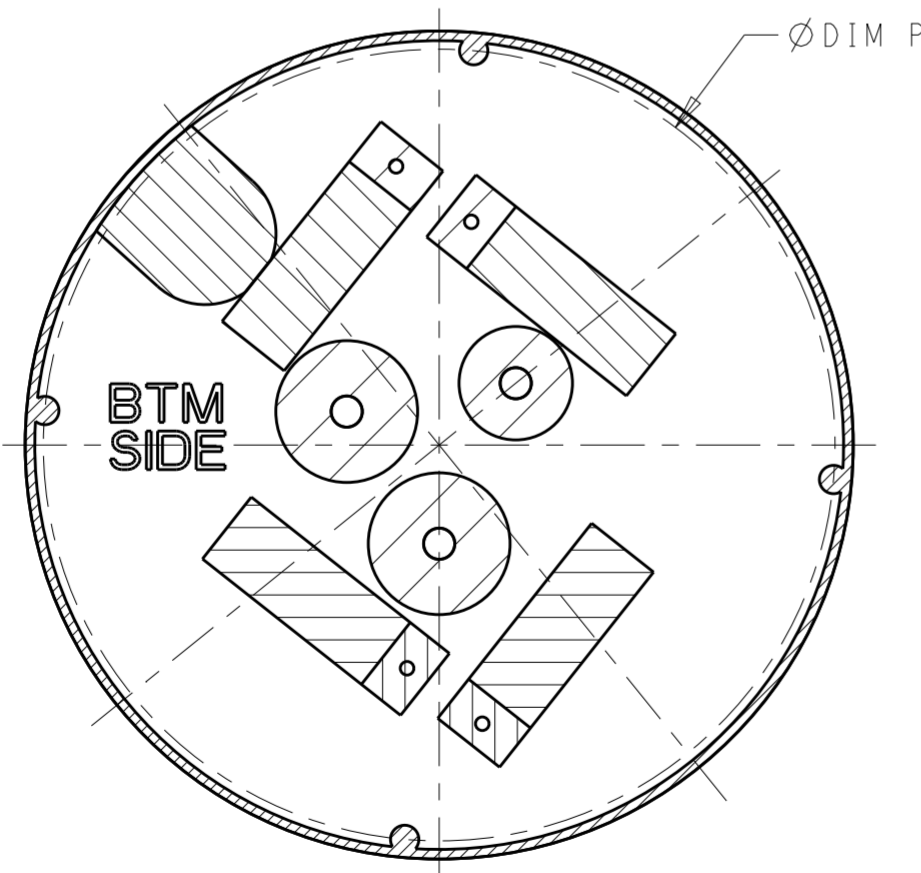
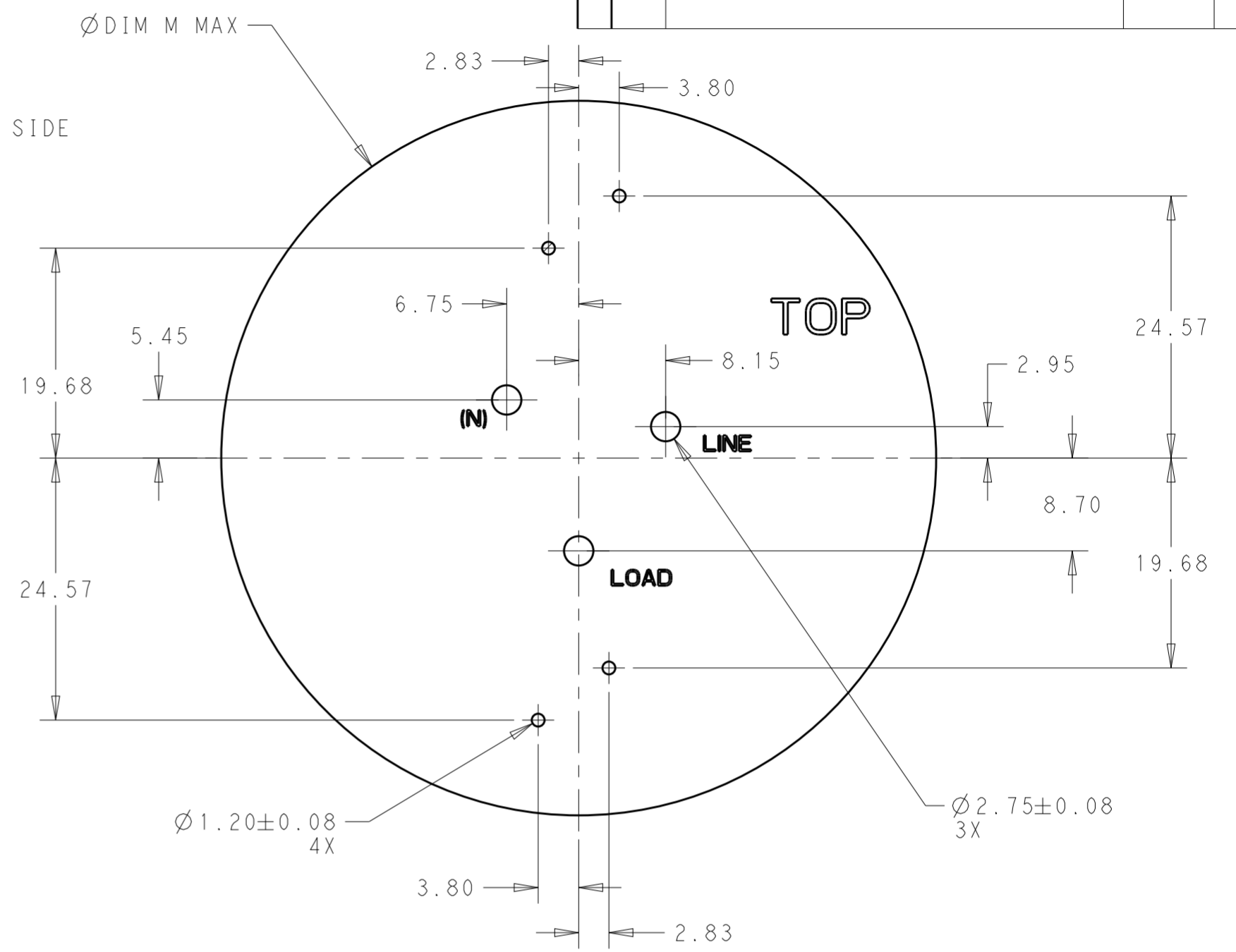

COMPONENT KEEP OUT AREAS
 1-2213871-1 AND 1-2213871-2

RECOMMENDED PCB
 SCALE 3:2

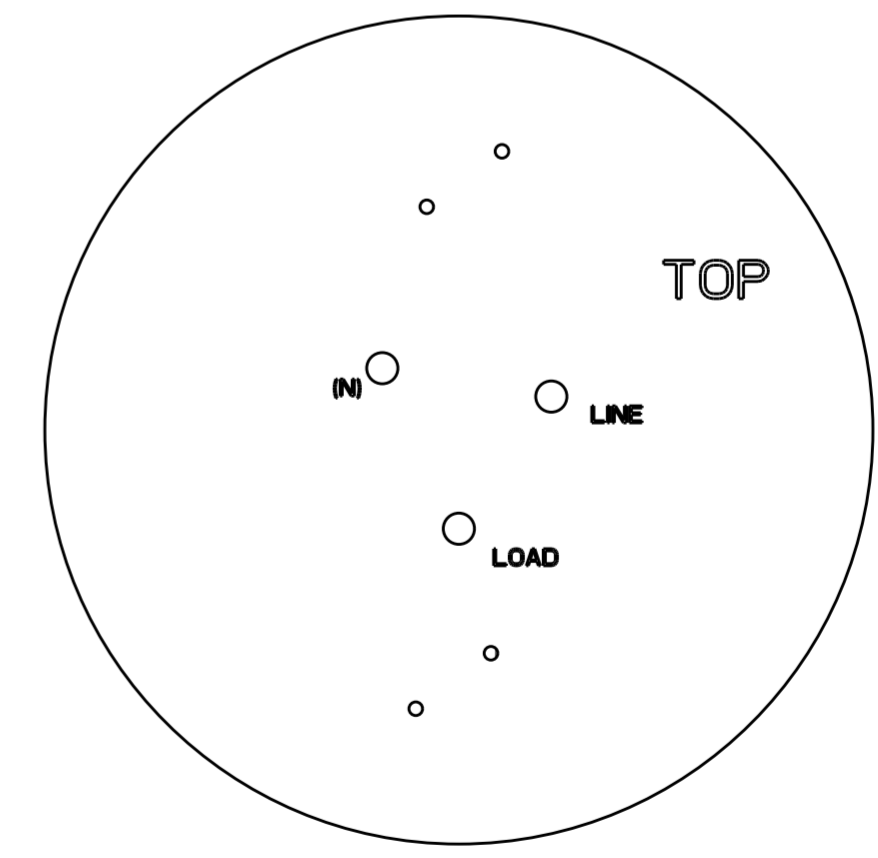

THIS DRAWING IS A CONTROLLED DOCUMENT.		DWN J. SHAFFER 23MAR2016	TE Connectivity	
		CHK E. HOWARD 23MAR2016		
DIMENSIONS:		APVD -	NAME BASE ASSEMBLY, LIGHT CONTROLLER, SLEEVE COMPATIBLE	
TOLERANCES UNLESS OTHERWISE SPECIFIED:		PRODUCT SPEC 108-32125	RESTRICTED TO	
MATERIAL		APPLICATION SPEC 114-32159	SIZE A2	CAGE CODE -
FINISH		WEIGHT	DRAWING NO C-2213871	REV B
		CUSTOMER DRAWING	SCALE 2:1	SHEET 3 OF 6

THIS DRAWING IS UNPUBLISHED. RELEASED FOR PUBLICATION 20
 © COPYRIGHT 20 BY - ALL RIGHTS RESERVED.

REVISIONS				
P	LTR	DESCRIPTION	DATE	APVD
-		SEE SHEET 1	-	-

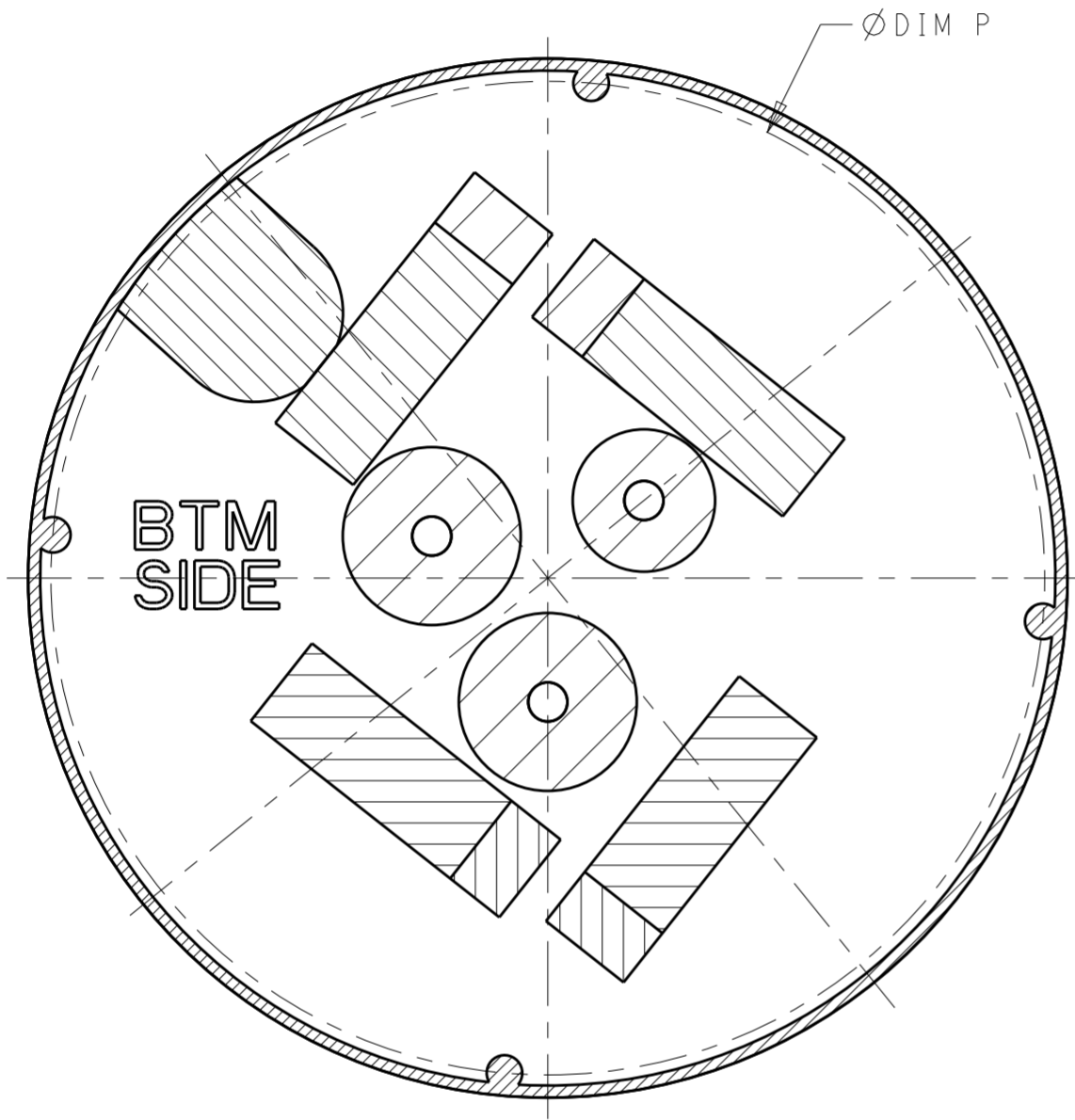

COMPONENT KEEP OUT AREAS
 1-2213871-3

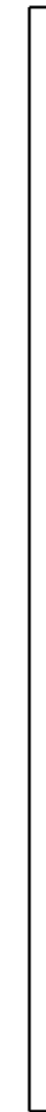

RECOMMENDED PCB
 SCALE 2:1

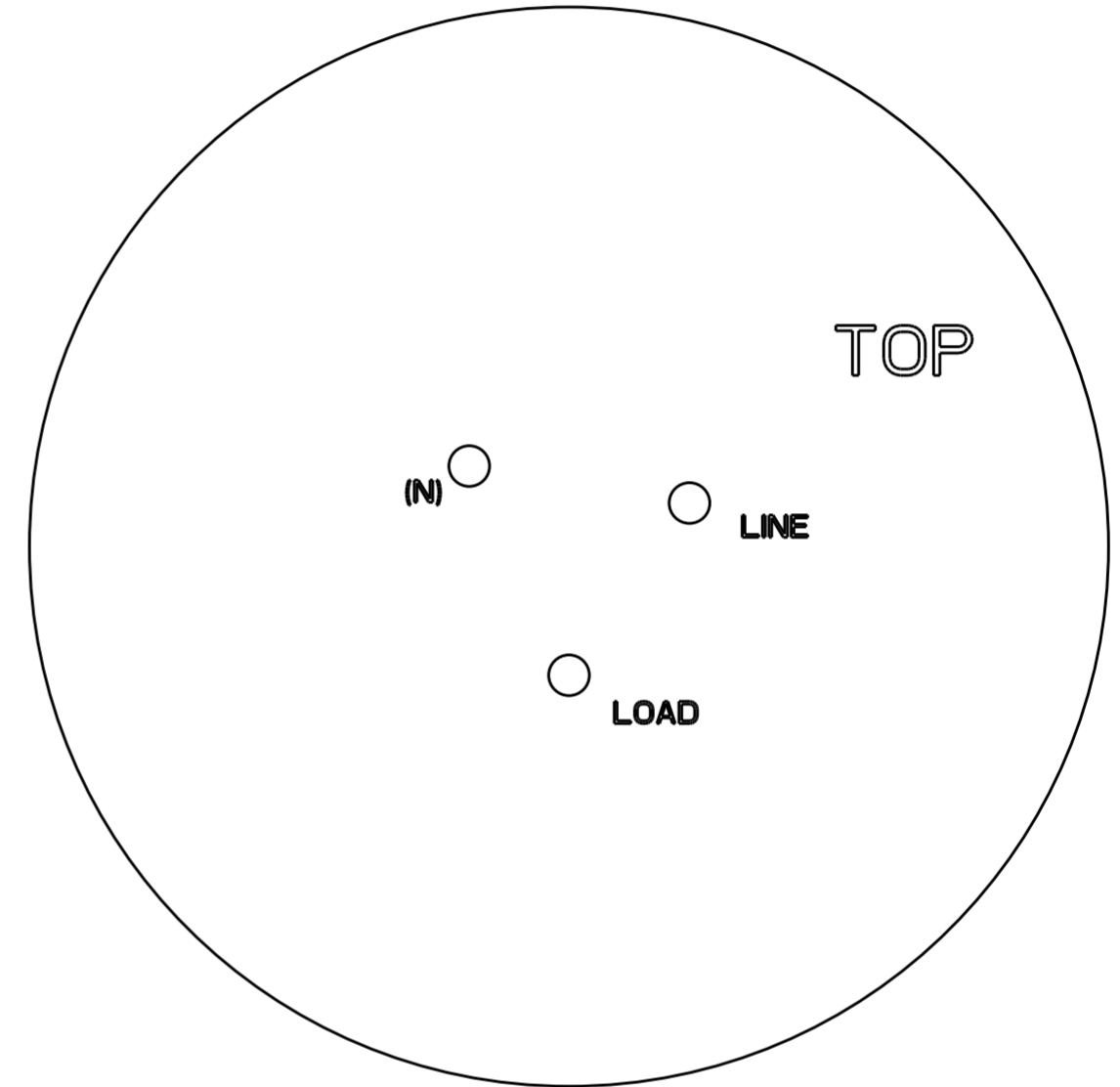

THIS DRAWING IS A CONTROLLED DOCUMENT.		DWN J. SHAFFER 23MAR2016	TE Connectivity	
		CHK E. HOWARD 23MAR2016		
DIMENSIONS: mm		TOLERANCES UNLESS OTHERWISE SPECIFIED: 0 PLC ± 1 PLC ±0.2 2 PLC ±0.13 3 PLC ± 4 PLC ± ANGLES ±3° FINISH		NAME BASE ASSEMBLY, LIGHT CONTROLLER, SLEEVE COMPATIBLE
		PRODUCT SPEC 108-32125 APPLICATION SPEC 114-32159	SIZE A2	CAGE CODE -
MATERIAL -		WEIGHT -	DRAWING NO C-2213871	RESTRICTED TO -
		CUSTOMER DRAWING		SCALE 2:1 SHEET 4 OF 6 REV B

THIS DRAWING IS UNPUBLISHED. RELEASED FOR PUBLICATION 20
 © COPYRIGHT 20 BY - ALL RIGHTS RESERVED.

REVISIONS					
P	LTR	DESCRIPTION	DATE	DWN	APVD
-	-	SEE SHEET 1	-	-	-

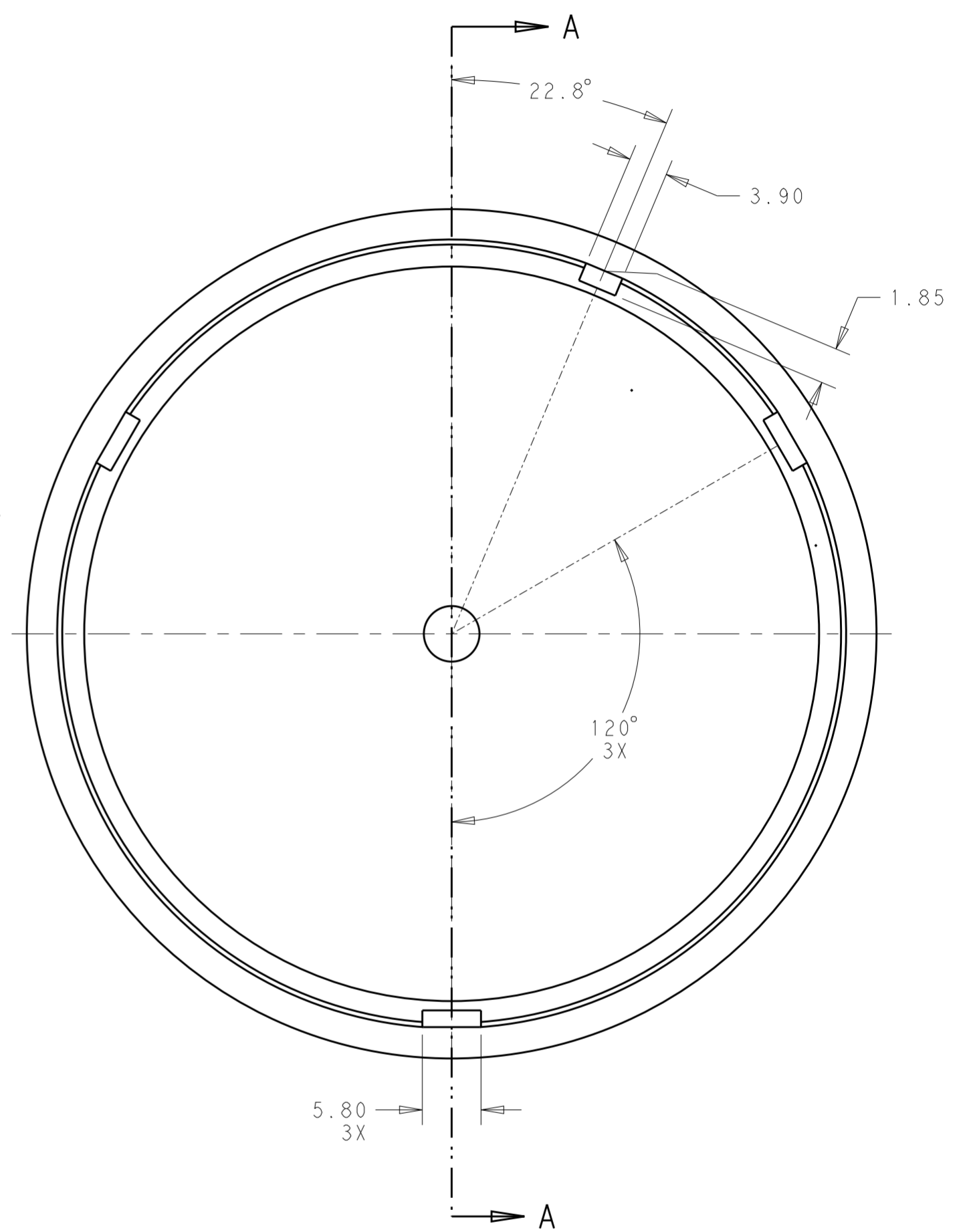
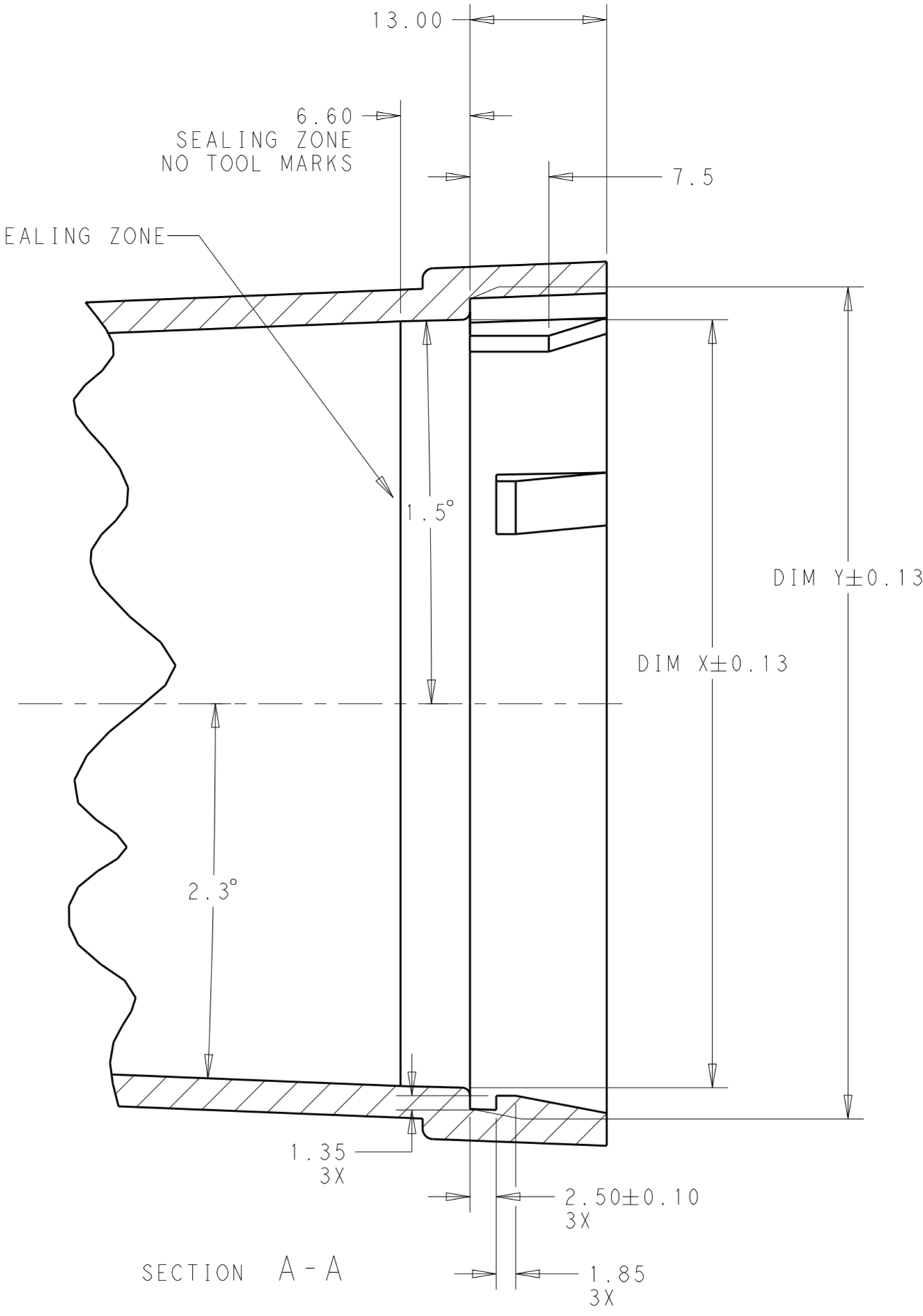
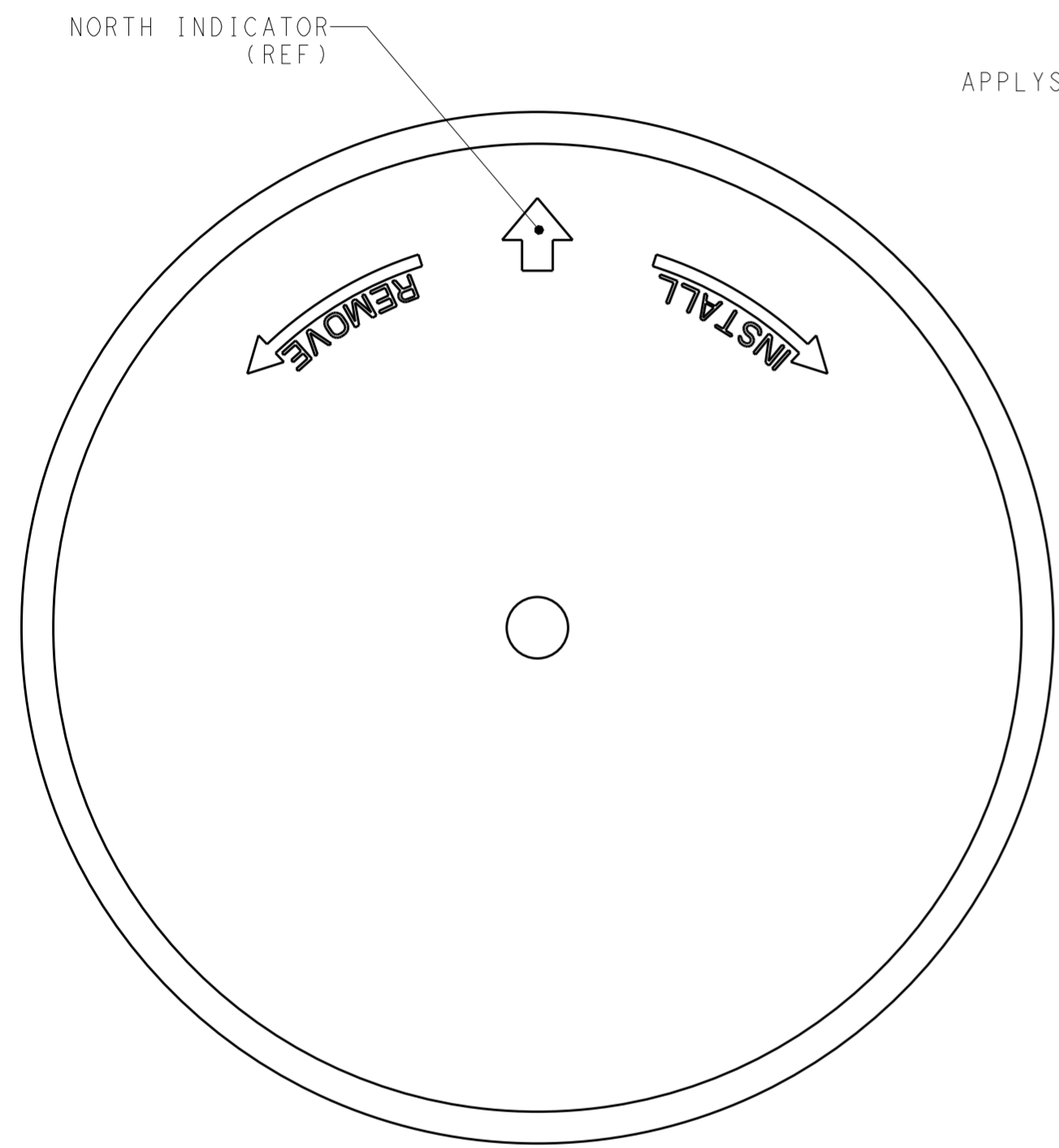

MATING COVER DIMENSIONS
 FOR
 76MM DIAMETER BASES
 (2213871-1, 1-2213871-1)

THIS DRAWING IS A CONTROLLED DOCUMENT.		DWN J. SHAFFER 23MAR2016	TE Connectivity	
		CHK E. HOWARD 23MAR2016		
DIMENSIONS: mm		TOLERANCES UNLESS OTHERWISE SPECIFIED: 0 PLC ± 1 PLC ±0.2 2 PLC ±0.13 3 PLC ± 4 PLC ± ANGLES ±3° FINISH -		NAME BASE ASSEMBLY, LIGHT CONTROLLER, SLEEVE COMPATIBLE
MATERIAL -		PRODUCT SPEC 108-32125 APPLICATION SPEC 114-32159 WEIGHT -		SIZE A2
		CUSTOMER DRAWING		DRAWING NO C-2213871
		SCALE 2:1		SHEET 5 OF 6 REV B