

LOC	DIST	REVISIONS			
GP	00	REV	DATE	BY	APPV
		A	11APR2014	LAW	EB

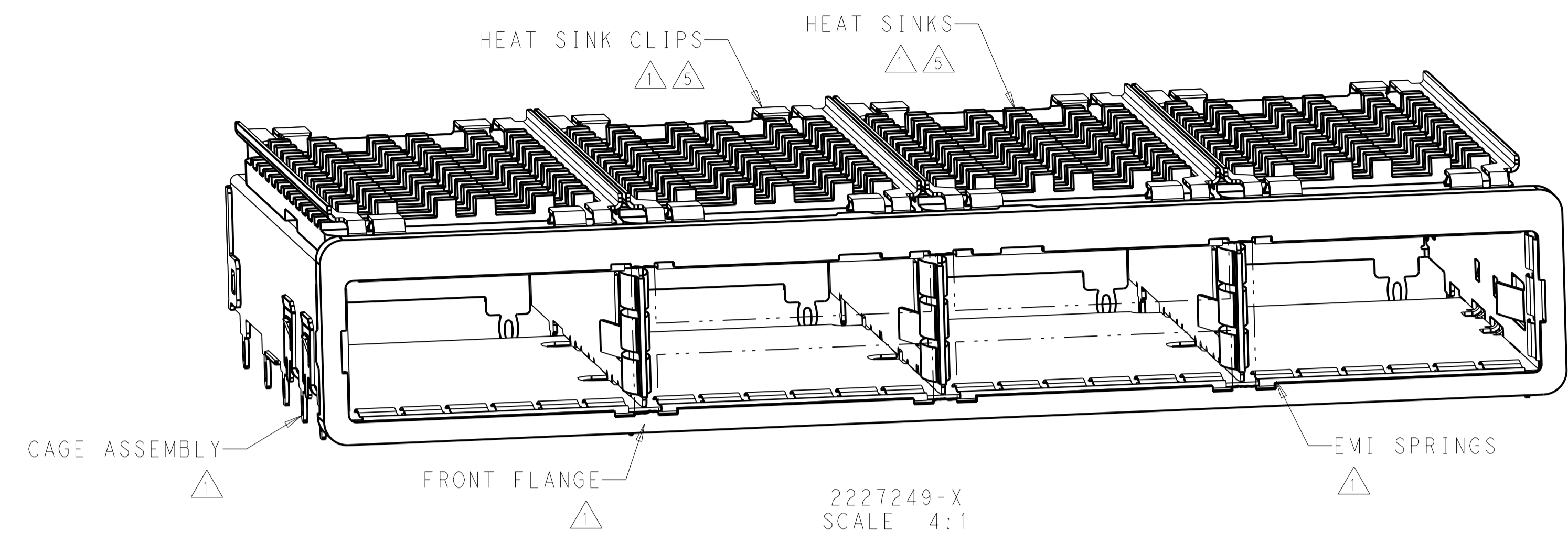

- 1. MATERIALS/FINISH:
CAGE ASSEMBLY - NICKEL-SILVER ALLOY, (0.25) THICK
EMI SPRINGS - COPPER ALLOY/2µm MIN TIN
FRONT FLANGE - ZINC ALLOY/3µm MIN TIN OVER 1.27µm MIN NICKEL OVER 5.08µm MIN COPPER
HEAT SINK - ALUMINUM/NICKEL
HEAT SINK CLIP - STAINLESS STEEL
- 2. SPACING BETWEEN CAGES ON THE SAME PCB TO BE SPECIFIED BY THE CUSTOMER, MUST COMPLY WITH MINIMUM DIMENSION SHOWN
- 3. REFERENCE APPLICATION SPECIFICATION 114-32023 FOR RECOMMENDED DRILL HOLE DIAMETER AND PLATING THICKNESS
- 4. DATUMS AND BASIC DIMENSIONS ESTABLISHED BY CUSTOMER
- 5. HEAT SINKS AND CLIPS ARE SHIPPED ASSEMBLED, CAGE ASSEMBLY MAY BE PRESSED INTO THE PCB AS SHIPPED
- 6. DIMENSION APPLIES WITH MODULE INSERTED IN CAGE
- 7. UNPLATED THRU HOLE
- 8. MATES WITH QSFP MSA COMPATIBLE TRANSCEIVER
- 9. SURFACE TRACES PERMITTED WITHIN THIS AREA EXCEPT WHERE CAGE STANDOFFS CONTACT PCB
- 10. BASELINE FOR THESE DIMENSIONS IS THE CENTER OF COMPLIANT PIN HOLE
- 11. DATE CODE (YYWWD) IS MARKED ON TOP OF CAGE BUT IS CONCEALED BY HEAT SINKS, APPLIES TO CAGE ASSEMBLY ONLY
- 12. REFERENCE APPLICATION SPECIFICATION 114-32023 FOR GASKET THICKNESS CALCULATION
- 13. DIMENSION C IS THE NOMINAL THICKNESS OF THE CUSTOMER SUPPLIED PC BOARD:
SINGLE SIDED PC BOARD MINIMUM THICKNESS - 1.45
DOUBLE SIDED PC BOARD MINIMUM THICKNESS - 2.4

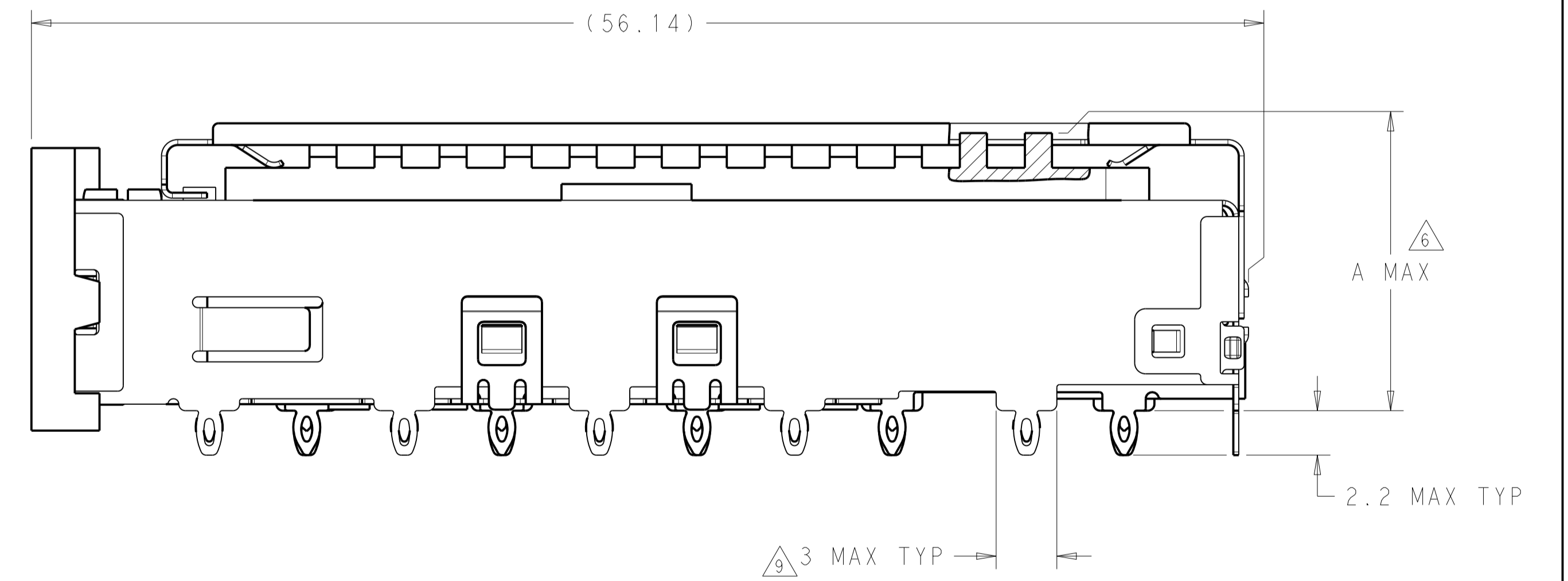
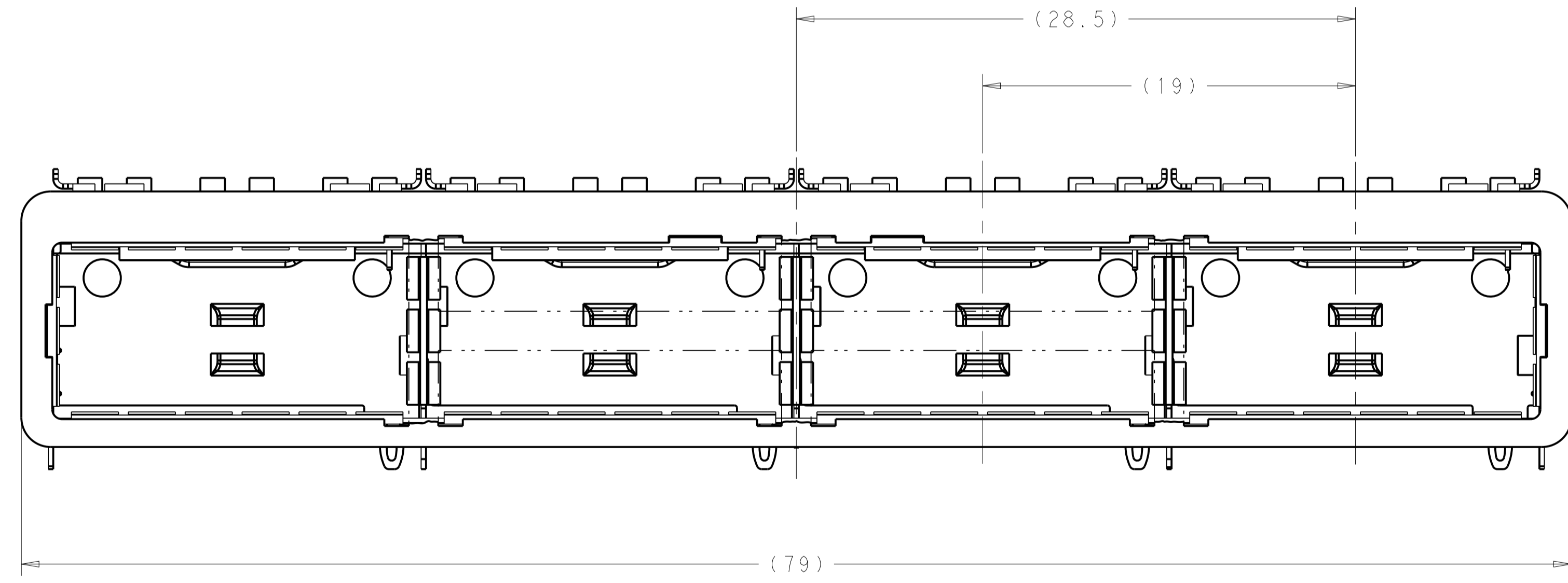

23	NETWORKING	2227249-3
16	SAN	2227249-2
13.7	PCI	2227249-1
A	HEAT SINK PROFILE	PART NUMBER

THIS DRAWING IS A CONTROLLED DOCUMENT. DIMENSIONING AND TOLERANCING PER ASME Y14.5M-2009.

STE TE Connectivity

RECEPTACLE ASSEMBLY WITH HEAT SINKS, BEHIND BEZEL, 1X4, QSFP28

Customer Drawing

SCALE 5:1 SHEET 1 OF 4 REV A

LOC	DIST	REV	DATE	BY	APPV
GP	00				

REVISIONS			
NO.	DESCRIPTION	DATE	BY
-	SEE SHEET 1	-	-

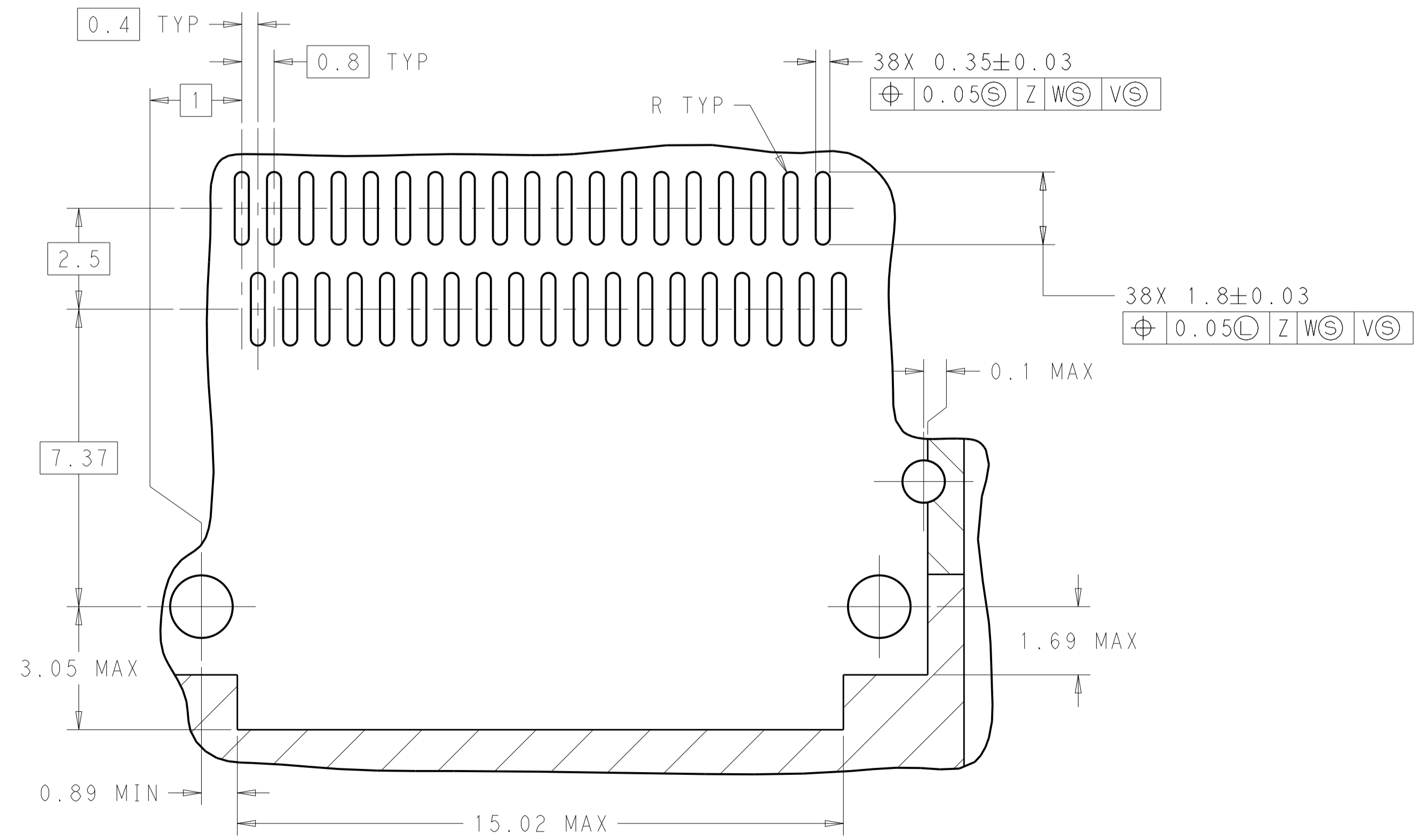
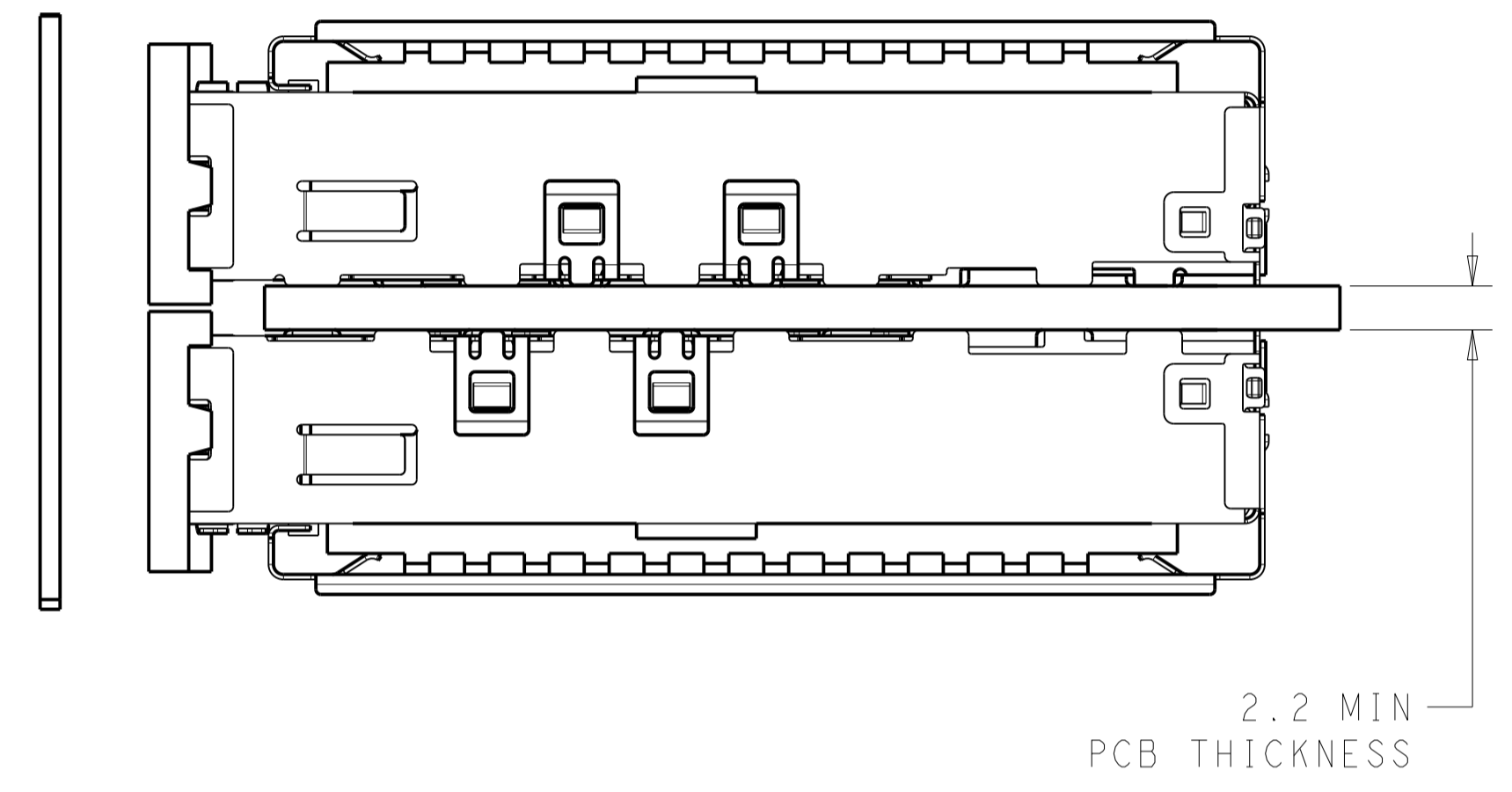
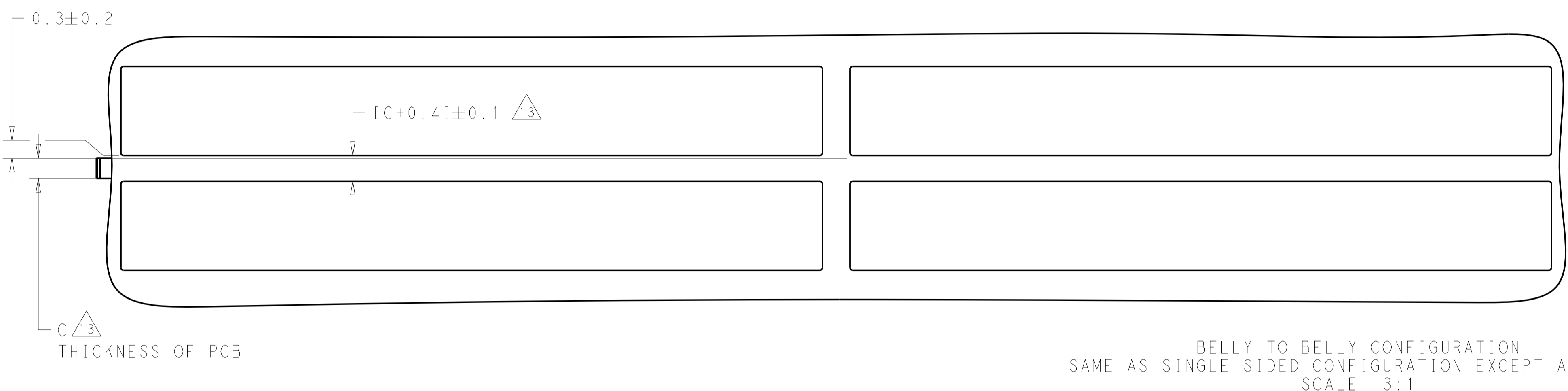
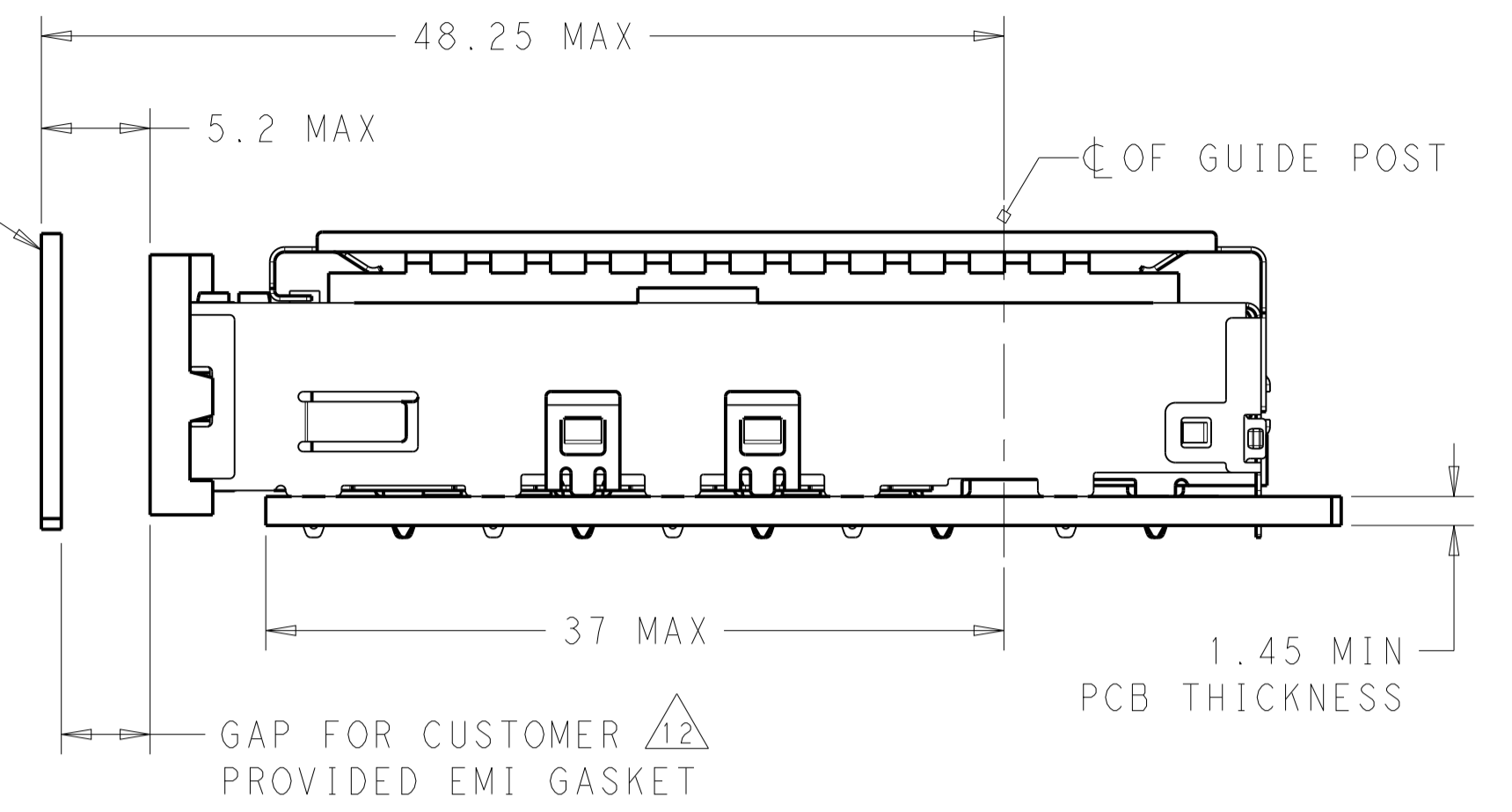
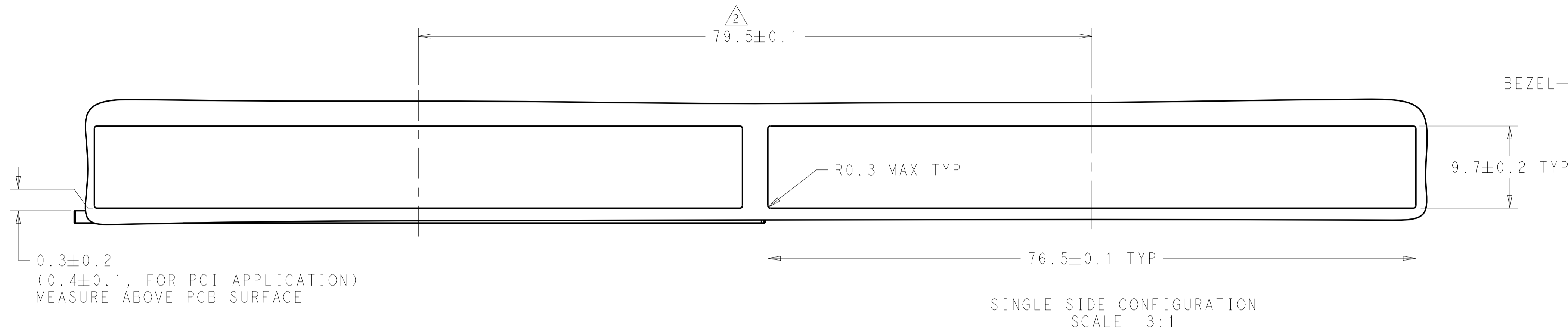

DETAIL A
 4X INDIVIDUALLY
 APPLIES TO BOTH SINGLE SIDE MOUNT
 AND BELLY TO BELLY CONFIGURATION
 SCALE 10:1

THIS DRAWING IS A CONTROLLED DOCUMENT. DIMENSIONING AND TOLERANCING PER ASME Y14.5M-2009.		OWN: M.E. CONNER 15AUG2012 CHK: R.R. HENRY 16AUG2012 APPV: R.R. HENRY 16AUG2012	TE Connectivity NAME: RECEPTACLE ASSEMBLY WITH HEAT SINKS, BEHIND BEZEL, 1X4, QSFP28 PRODUCT SPEC: - APPLICATION SPEC: -
DIMENSIONS: mm	TOLERANCES UNLESS OTHERWISE SPECIFIED: 0 PLC ±0.2 1 PLC ±0.15 2 PLC ±0.1 3 PLC ±0.05 4 PLC ±0.025 ANGLES ±1	SIZE: A1 CAGE CODE: 00779 DRAWING NO: C=2227249 RESTRICTED TO: -	
MATERIAL: SEE NOTES	FINISH: SEE NOTES	WEIGHT: -	SCALE: 4:1 SHEET 2 OF 4 REV A

LOC	DIST	REV	DATE	BY	APPV
GP	00				
REVISIONS			DATE	BY	APPV
- SEE SHEET 1			-	-	-

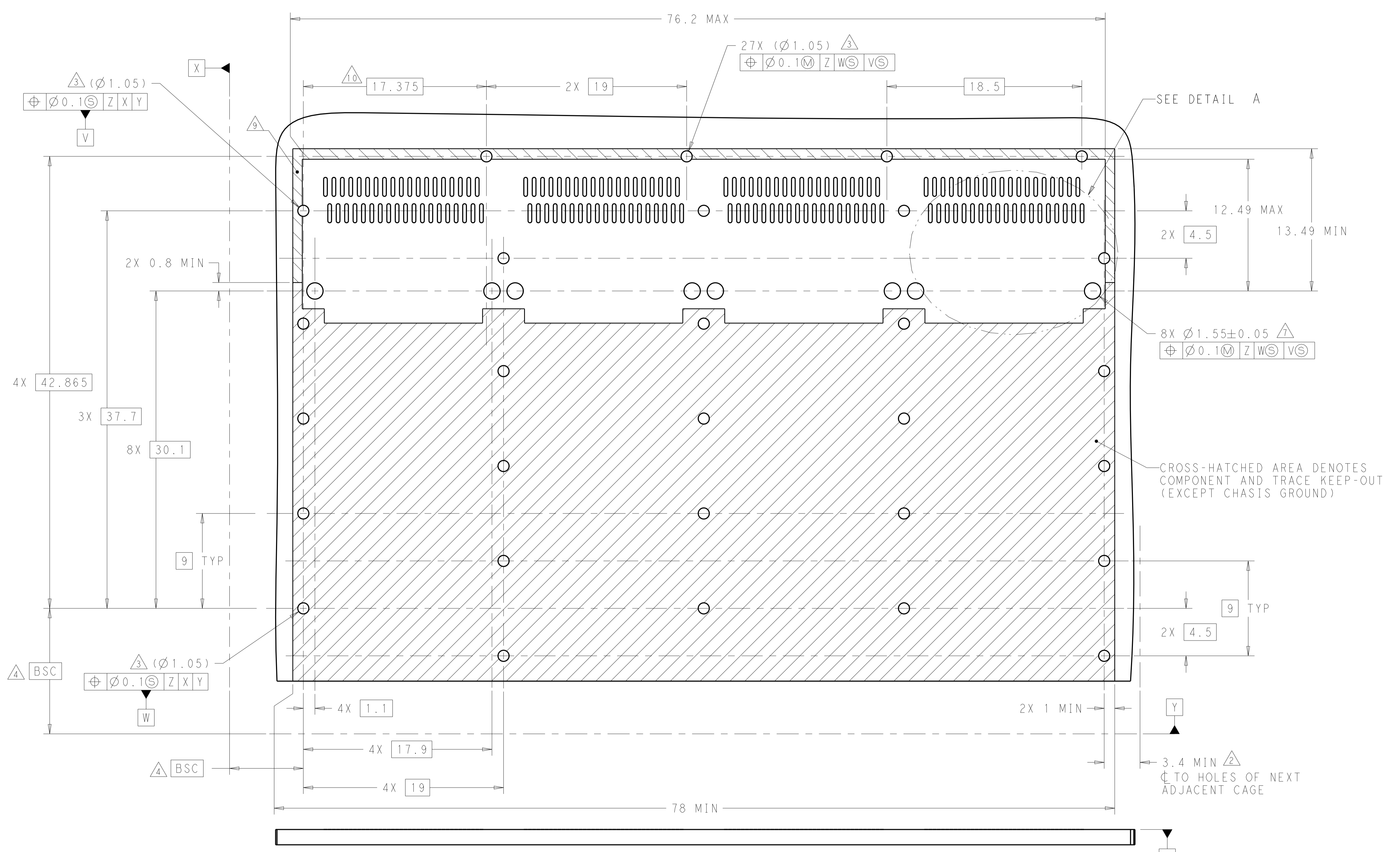

SEE DETAIL A

CROSS-HATCHED AREA DENOTES COMPONENT AND TRACE KEEP-OUT (EXCEPT CHASSIS GROUND)

3.4 MIN Δ TO HOLES OF NEXT ADJACENT CAGE

RECOMMENDED PCB LAYOUT
SINGLE SIDE MOUNT CONFIGURATION
SCALE 5:1

THIS DRAWING IS A CONTROLLED DOCUMENT. DIMENSIONING AND TOLERANCING PER: ASME Y14.5M-2009		DWN: M.E. CONNER 15AUG2012 CHK: R.R. HENRY 16AUG2012 APVD: R.R. HENRY 16AUG2012	STE TE Connectivity NAME: RECEPTACLE ASSEMBLY WITH HEAT SINKS, BEHIND BEZEL, 1X4, QSFP28 PRODUCT SPEC: - APPLICATION SPEC: -
DIMENSIONS: mm 	TOLERANCES UNLESS OTHERWISE SPECIFIED: 0 PLC ±0.2 1 PLC ±0.15 2 PLC ±0.1 3 PLC ±0.05 4 PLC ±0.025 ANGLES ±1	SIZE: A1 CAGE CODE: 00779 DRAWING NO: C=2227249 WEIGHT: - FINISH: SEE NOTES	RESTRICTED TO: - SCALE: 4:1 SHEET: 3 OF 4 REV: A