

THIS DOCUMENT IS THE PROPERTY OF KEYSTONE ELECTRONICS CORP. AND SHALL NOT BE REPRODUCED, DISTRIBUTED OR USED AS A BASIS FOR MANUFACTURE WITHOUT PRIOR WRITTEN PERMISSION FROM KEYSTONE ELECTRONICS CORP.

**ACTUAL SIZE**

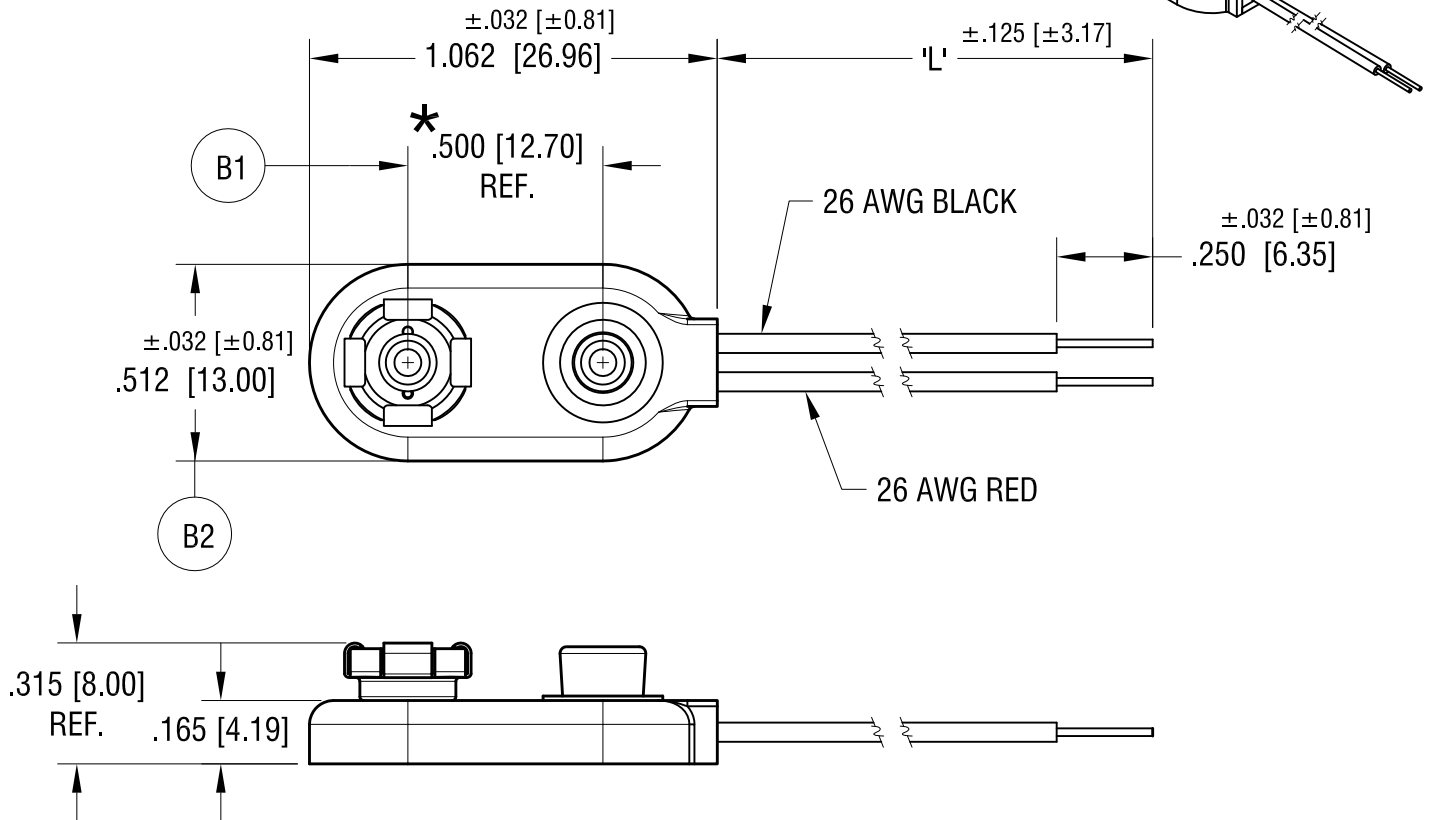

**NOTE:**

1. MAT'L - WIRE: 26 AWG, 1007 UL/CSA APPROVED
2. CONTACTS: PHOSPHOR BRONZE, NICKEL PLATE
3. BODY: MOLDED POLYETHYLENE
4. RED WIRE CONNECTED TO FEMALE CONTACT; BLACK WIRE CONNECTED TO MALE CONTACT.
5. ★ REF. DIMENSION MUST FIT INDUSTRY STANDARD 9 VOLT BATTERY.

PART NO.	'L' DIM.
2238	4.000 [101.60]
2239	6.000 [152.40]
2240	8.000 [203.20]

DATE	DESCRIPTION	REV.
8.23.21	(B1) AWS .512+.015/-0.005, ADD NOT ECN 21-095, (B2) WAS .512±.020	5. B
3.10.05	CHANGE AS PER ECN 05-016	A

**KEYSTONE ELECTRONICS CORP.**  
 www.keyelco.com • NEW HYDE PARK, NY 11040 • Tel (516) 328-7500

PART NAME  
**PREMIUM '9' VOLT 'I' STYLE BATTERY STRAP**

MATERIAL  
**AS NOTED**

FINISH <b>AS NOTED</b>	DRN BY BOONE	DATE 8.08.95
	APP'D LN	SCALE 2X

TOLERANCES INCH [MM]  
 DECIMAL ±.005 [±0.13]  
 ANGULAR ± 1°  
 UNLESS OTHERWISE SPECIFIED

CODE  
**C**

DWG NO.  
**2238-2240**