

LOC		DIST		REVISIONS			
P	LTN	DESCRIPTION	DATE	DWN	APVD		
A		INITIAL RELEASE	18FEB2014	BM	DG		
B		REVISED PER ECO-16-006997	09MAY2016	JY	SH		

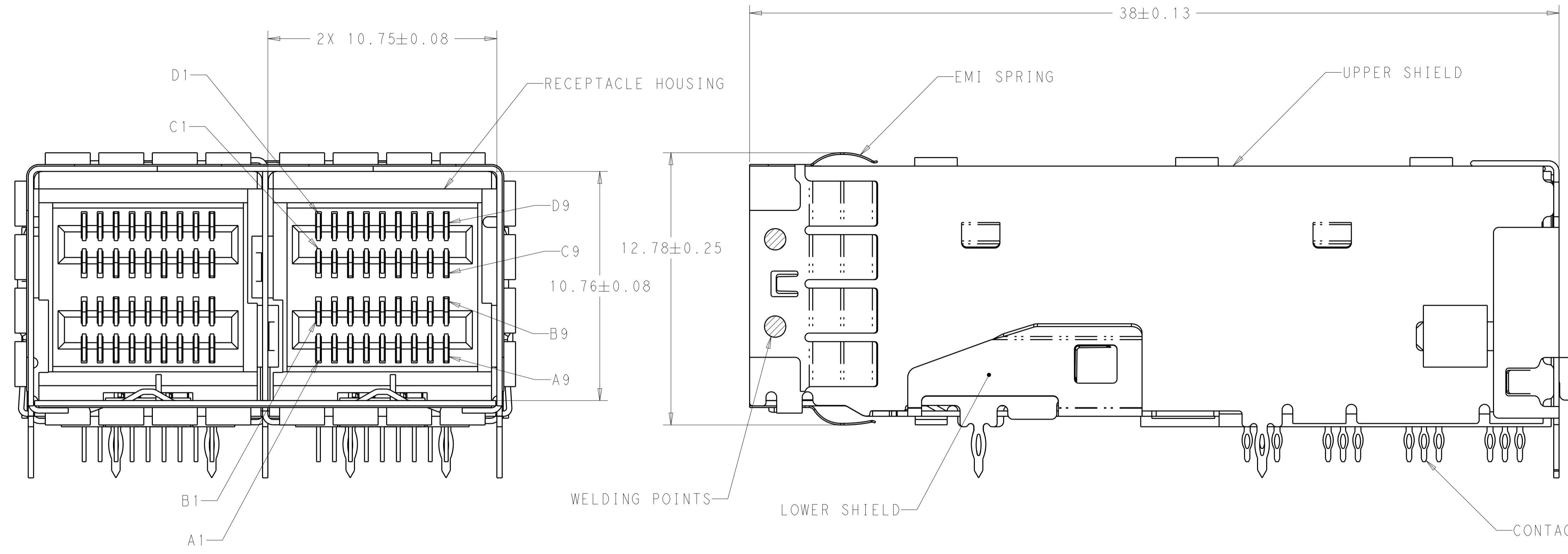

1. MATERIALS  
 RECEPTACLE HOUSING, LCP, BLACK, UL94V-0 RATED  
 SHIELD ASSY: NICKEL SILVER COPPER ALLOY  
 CONTACTS: COPPER ALLOY  
 EMI SPRING: COPPER ALLOY  
 THREADED NUT: BRASS  
 CHICKLETS: LCP, BLACK, UL 94V-0 RATED
2. FINISH  
 EMI SPRING: TIN PLATE OVER NICKEL PLATE  
 NON-PLATED EDGES PERMISSABLE  
 THREADED NUT: NICKEL PLATE
3. CONTACT FINISH: 0.76µm MIN GOLD IN CONTACT AREA, 1.25µm MIN TIN ON PCB TAILS. ALL OVER 1.27µm NICKEL UNDERPLATE.
4. THREAD LENGTH OF FASTENER = PCB THICKNESS + 1.45 MAX
5. THIS PRODUCT HAS NOT COMPLETED VALIDATION/QUALIFICATION TESTING
6. RECOMMENDED TRACE KEEP OUT ZONE

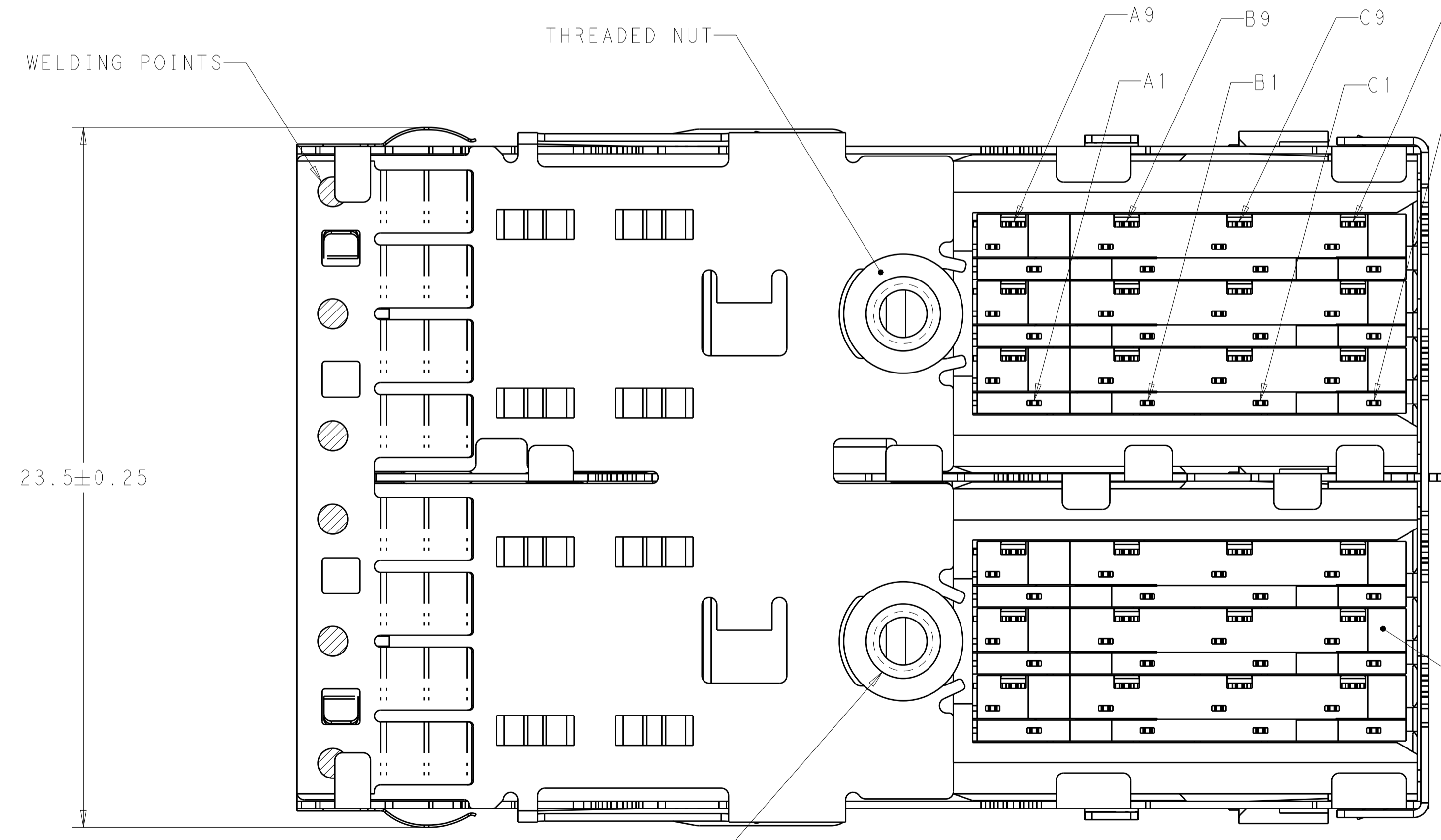

2274682-1  
 PART NUMBER

THIS DRAWING IS A CONTROLLED DOCUMENT.		DWN B. MATTHEWS 18FEB2014	TE Connectivity
DIMENSIONS: mm		CHK D. GORENC 18FEB2014	
TOLERANCES UNLESS OTHERWISE SPECIFIED:		APVD D. GORENC 18FEB2014	NAME RECEPTACLE ASSEMBLY, MINI-SAS HD, 2X
0 PLC ±		PRODUCT SPEC 108-2462	SIZE CAGE CODE DRAWING NO. RESTRICTED TO
1 PLC ±		APPLICATION SPEC 114-13316	A100779C=2274682
2 PLC ±		WEIGHT	SCALE 8:1 SHEET 1 OF 2 REV B
3 PLC ±		MATERIAL	Customer Drawing
4 PLC ±		FINISH	
ANGLES ±			

LOC	DIST	REVISIONS			
P	LTN	DESCRIPTION	DATE	OWN	APVD
-	-	SEE SHEET 1	-	-	-

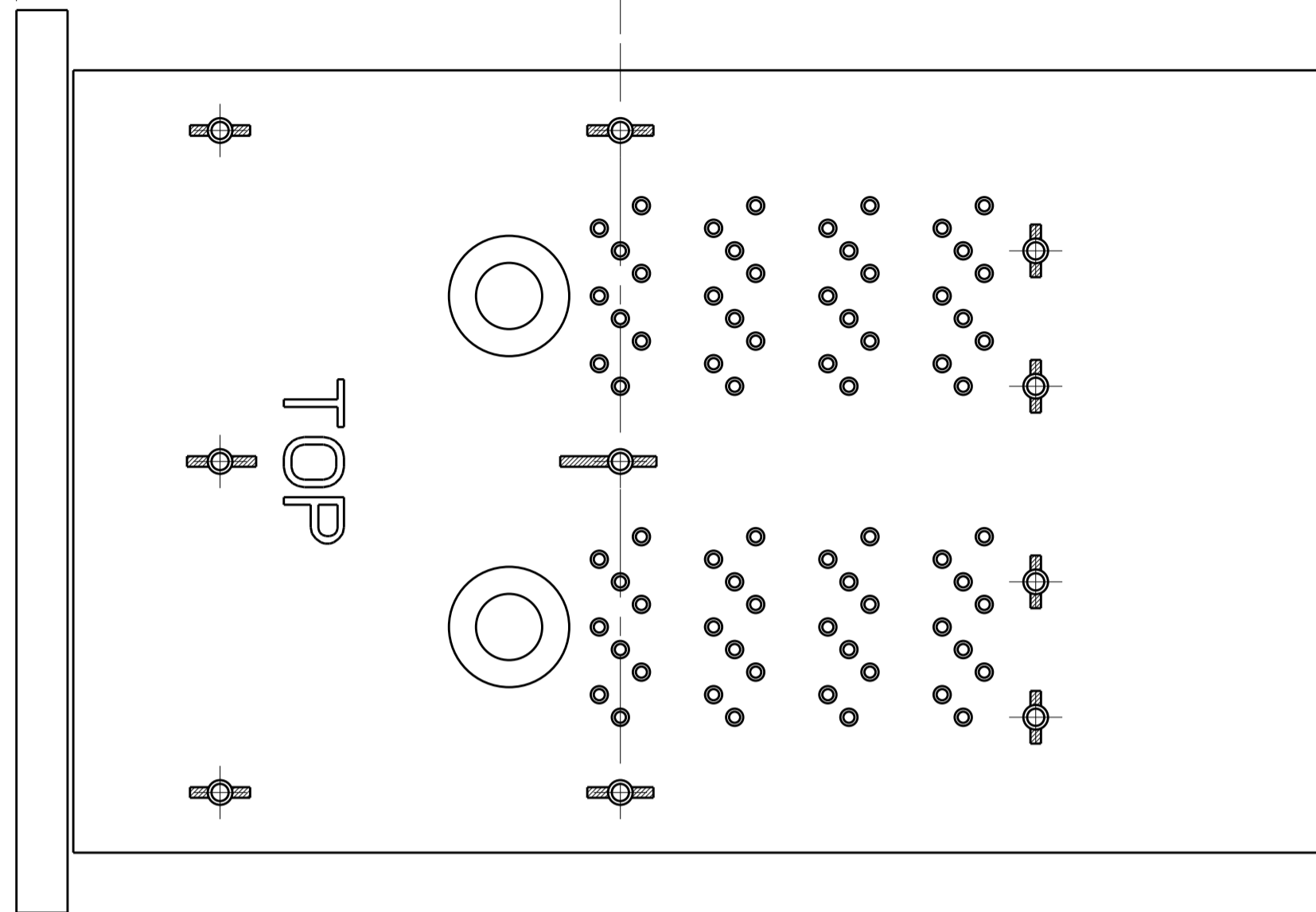
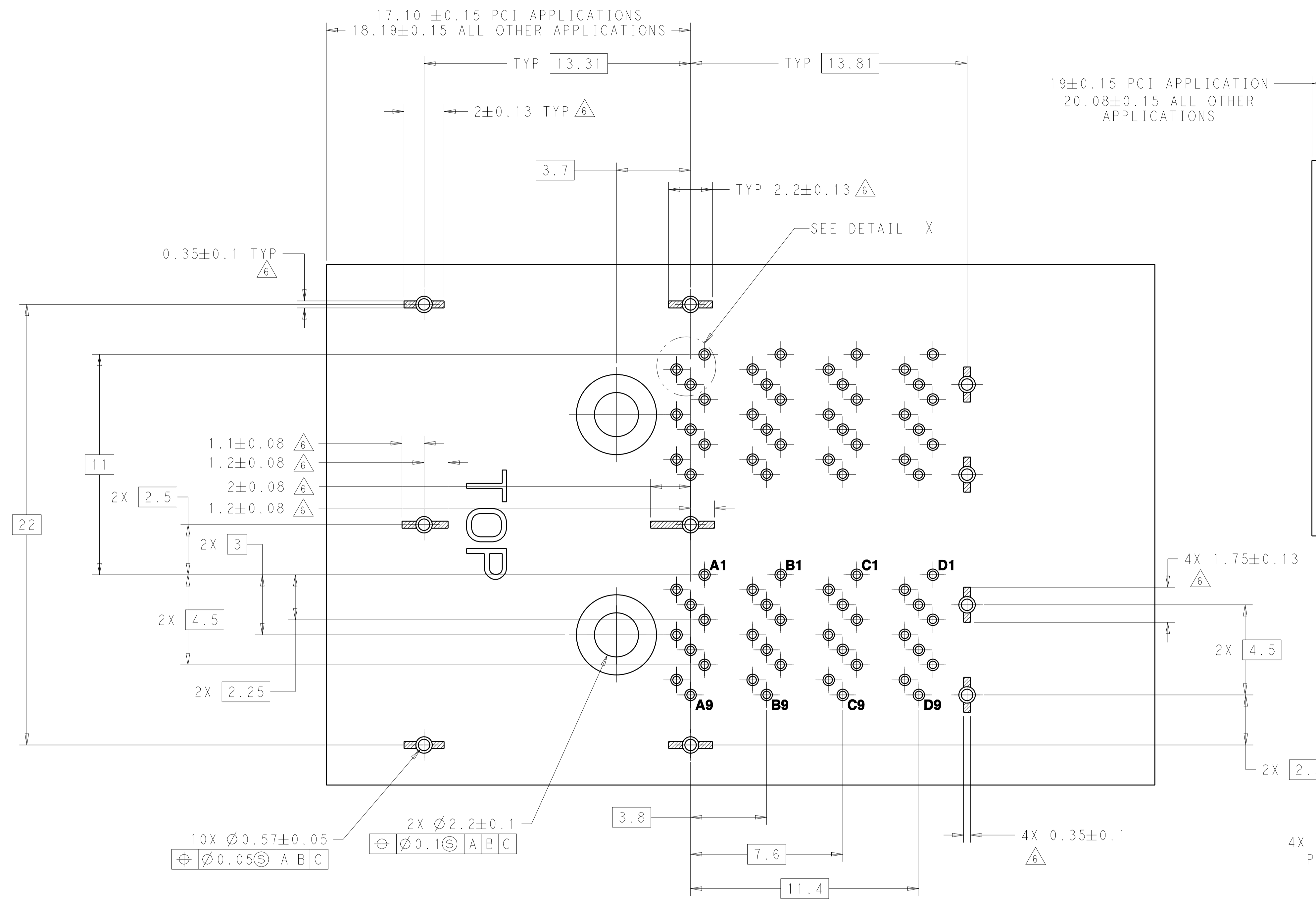

PANEL/PCB ASSEMBLY  
SCALE=5:1

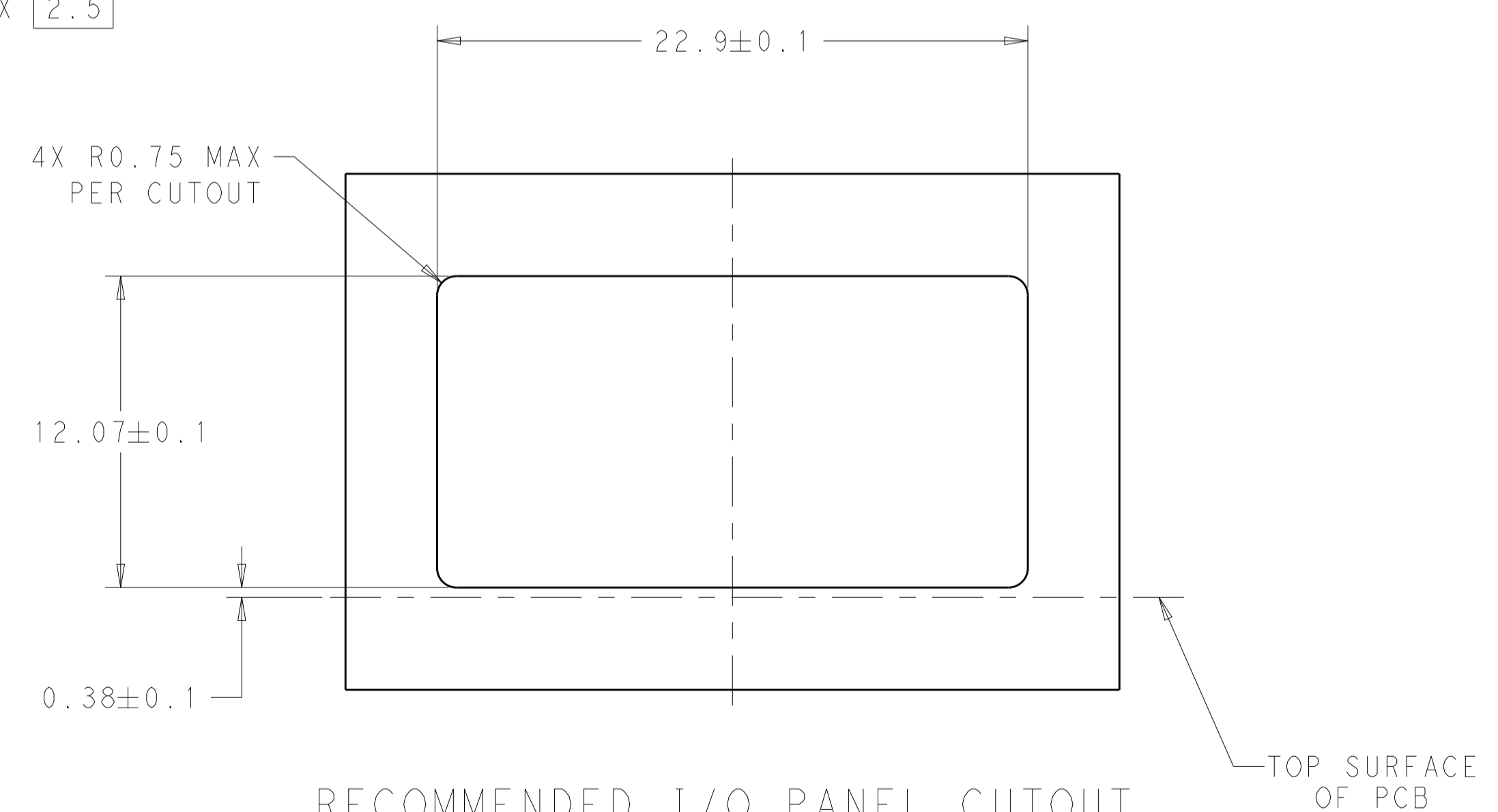

RECOMMENDED I/O PANEL CUTOUT  
SCALE=5:1

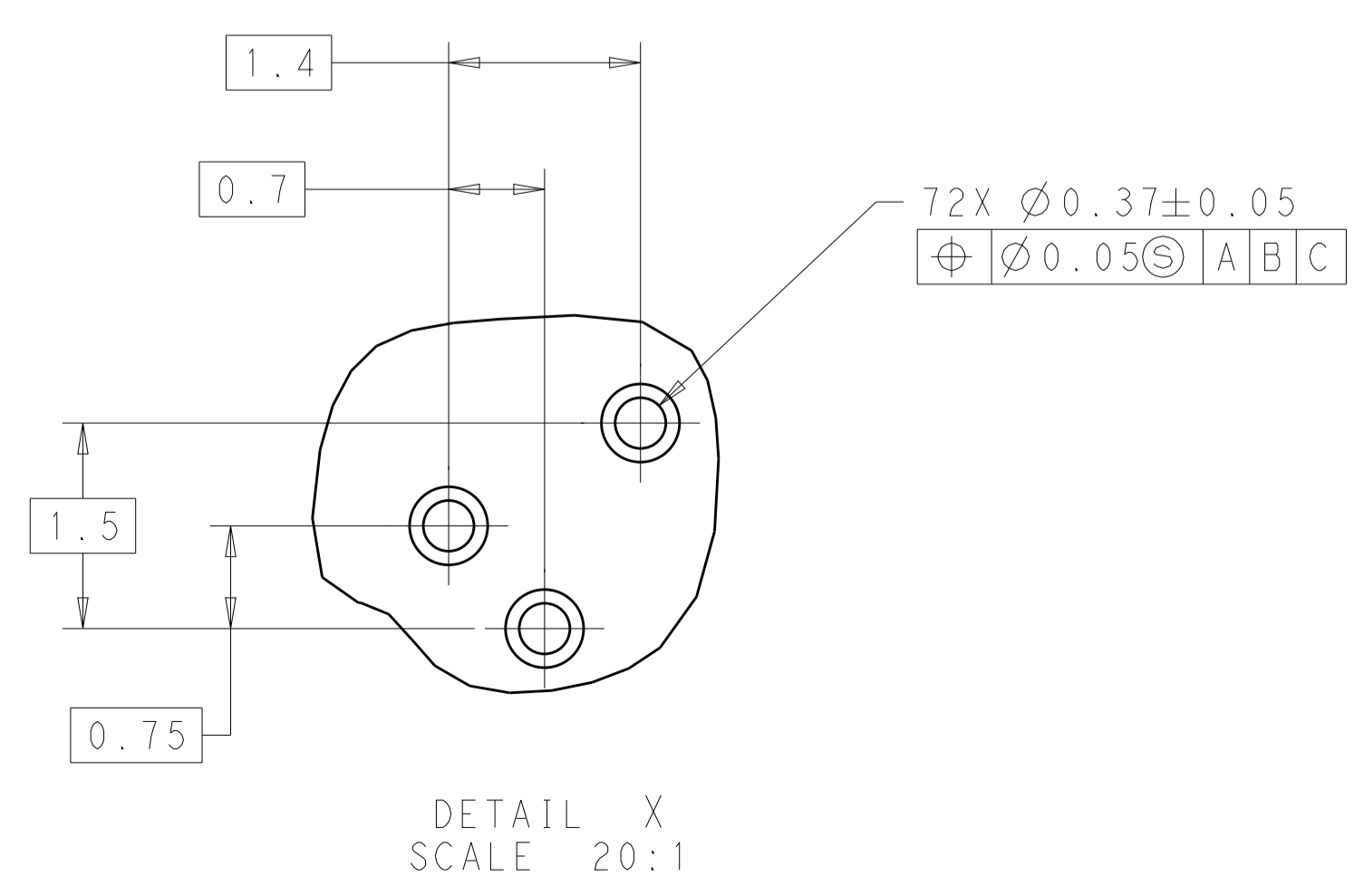
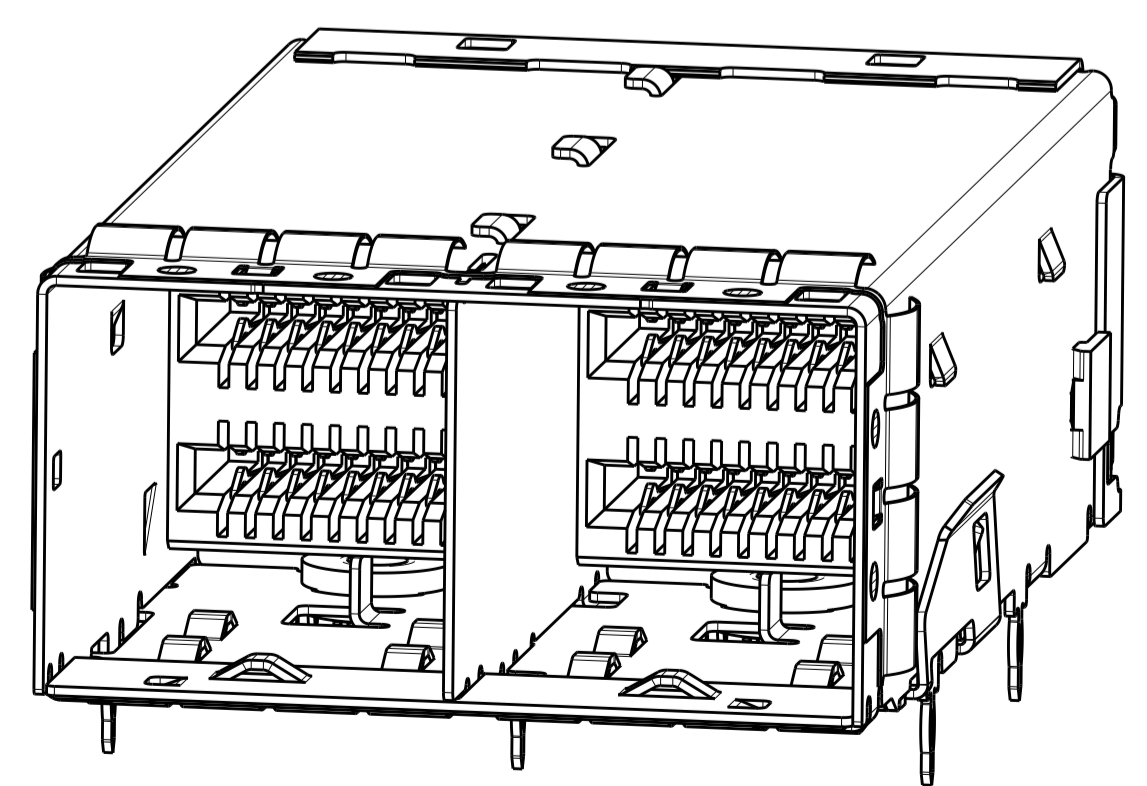

DETAIL X  
SCALE 20:1

THIS DRAWING IS A CONTROLLED DOCUMENT.		OWN B. MATTHEWS 18FEB2014	TE Connectivity
DIMENSIONS:		CHK D. GORENC 18FEB2014	
mm	TOLERANCES UNLESS OTHERWISE SPECIFIED:	APVD D. GORENC 18FEB2014	NAME
0 PLC ±	1 PLC ±	PRODUCT SPEC	RECEPTACLE ASSEMBLY, MINI-SAS HD, 2X
2 PLC ±	3 PLC ±	APPLICATION SPEC	SIZE CAGE CODE DRAWING NO
4 PLC ±	ANGLES ±	114-13316	RESTRICTED TO
MATERIAL	FINISH	WEIGHT	A100779C=2274682
Customer Drawing		SCALE 8:1	SHEET 2 OF 2 REV B