

THIS DRAWING IS UNPUBLISHED. RELEASED FOR PUBLICATION 20
 © COPYRIGHT 20 BY - ALL RIGHTS RESERVED.

REVISIONS				
P	LTR	DESCRIPTION	DATE	APVD
A		REVISED PER ECO-18-005007	23APR2018	AP EB

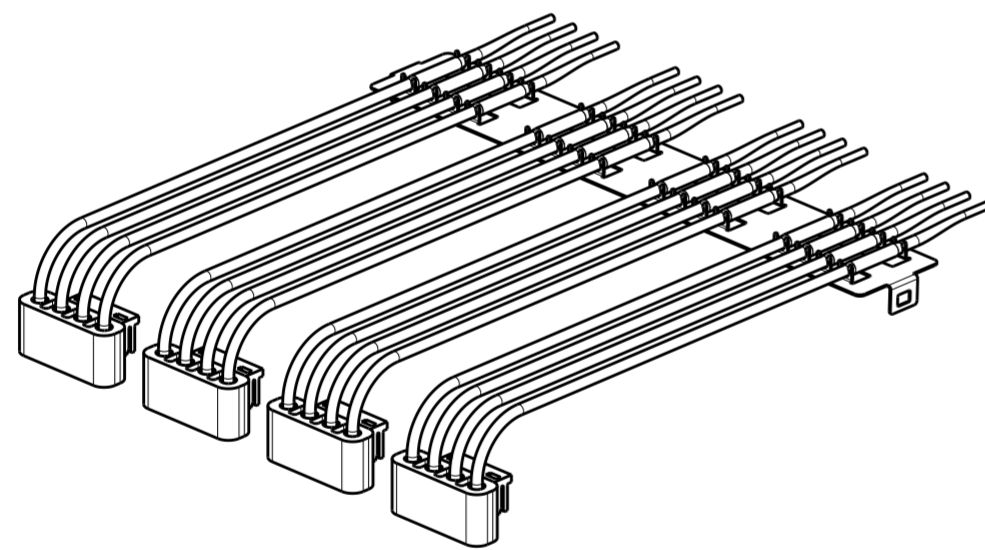

2325080-4
SCALE 1:1

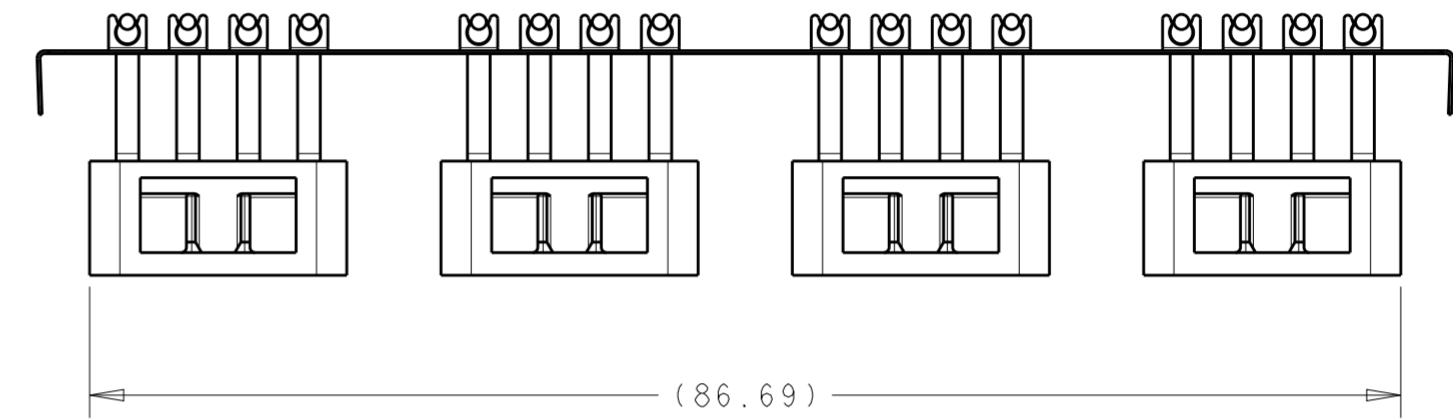
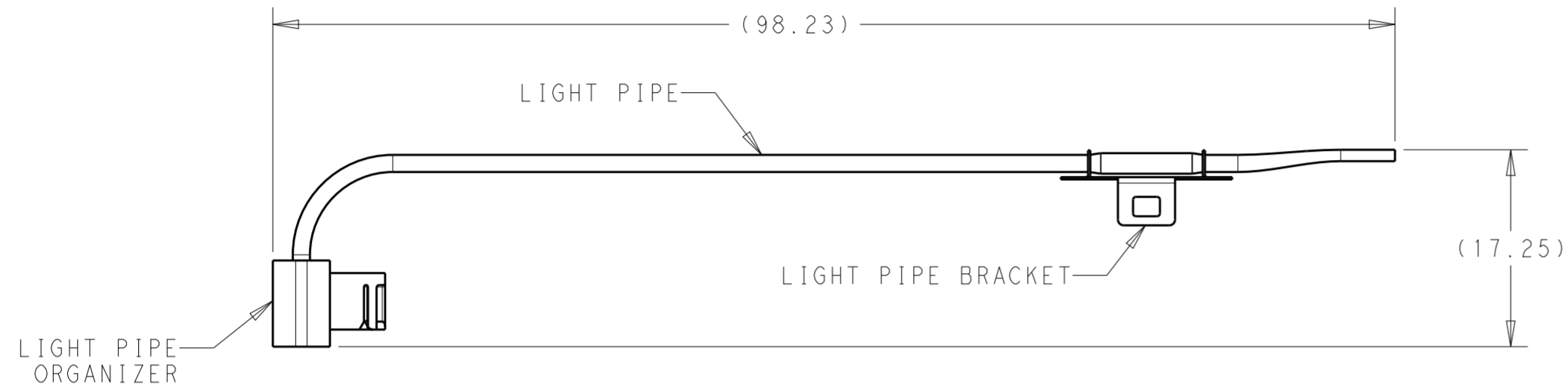
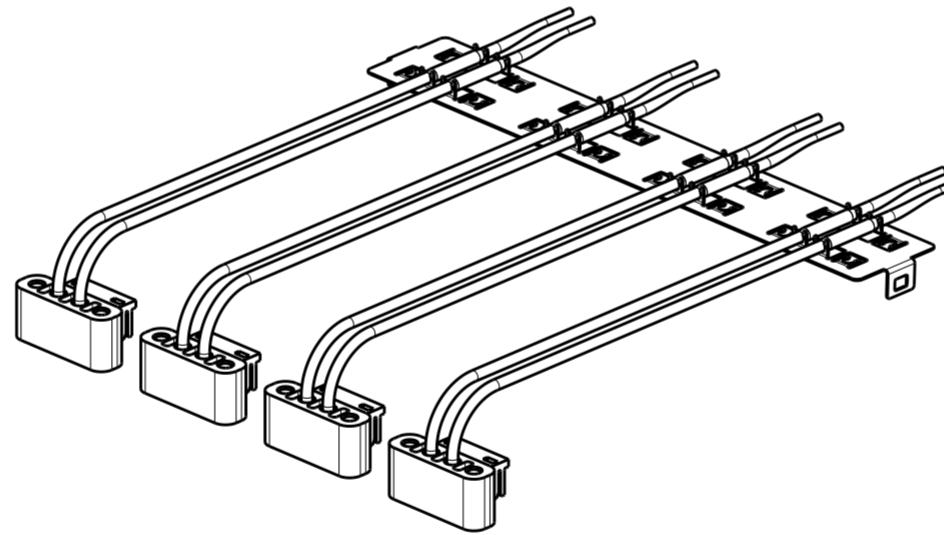

2325080-5
SCALE 1:1

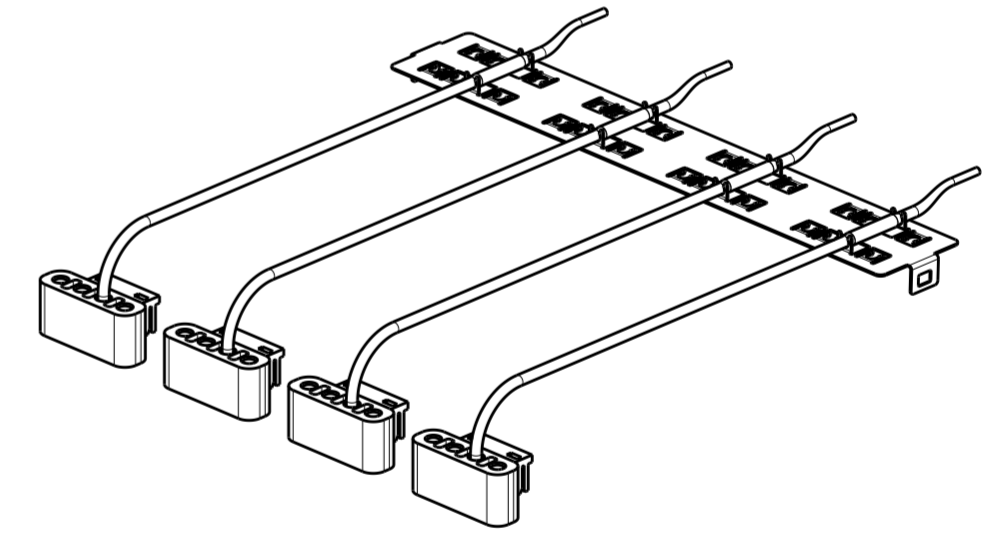

2325080-6
SCALE 1:1

1 LIGHT PIPE - CLEAR POLYCARBONATE.
 LIGHT PIPE ORGANIZER - POLYCARBONATE.
 LIGHT PIPE BRACKET - STAINLESS STEEL.

1	2325080-6
2	2325080-5
4	2325080-4
LIGHT PIPES PER PORT	PART NUMBER

THIS PRODUCT HAS NOT COMPLETED VALIDATION AND QUALIFICATION TESTING

THIS DRAWING IS A CONTROLLED DOCUMENT.		DWN M. SHIRK 17JAN2018	STE TE Connectivity	
		CHK E. BRIANT 17JAN2018		
DIMENSIONS: mm		APVD -	NAME LIGHT PIPE ASSEMBLY, 1X4, OSFP	
TOLERANCES UNLESS OTHERWISE SPECIFIED:		PRODUCT SPEC -	SIZE CAGE CODE DRAWING NO RESTRICTED TO	
0 PLC ±	1 PLC ±	APPLICATION SPEC -	A200779 C-2325080	
2 PLC ±	3 PLC ±	WEIGHT -	SCALE 2:1 SHEET 1 OF 1 REV A	
4 PLC ±	ANGLES ±	CUSTOMER DRAWING		
FINISH -				