

THIS DRAWING IS UNPUBLISHED. RELEASED FOR PUBLICATION 20
 © COPYRIGHT 20 BY - ALL RIGHTS RESERVED.

REVISIONS					
P	LTR	DESCRIPTION	DATE	DWN	APVD
B1		ECR-19-013004	26AUG2019	SR	JL
B2		ECR-20-000836	23JAN2020	SB	JL
B3		ECR-20-002949	02MAR2020	SR	JL
B4		ECR-20-006986	18MAY2020	SR	DD

- 1 MATERIALS:
 HOLDER: PBT ,COLOR: NATURAL;
 CONTACTS: COPPER ALLOY, Au/Ni PLATING (LED INTERFACE)
- 2. FOR SOLID, FUSED AND STRANDED CONDUCTOR WIRE TYPES AWG 18 AND 20
- 3. WIRE STRIP LENGTH: 11-12mm
- 4. MAX. WIRE INSULATION OUTER DIA: $\varnothing 2,3\text{mm}$
- 5. RECOMMENDED SCREW TORQUE: SEE APPLICATION SPECIFICATION 114-133107.
- 6. SCREWS TO BE USED: M3, #4-40
- 7. LED MATING ON 2 CORNERS WITH ADHESIVE TAPE 3M 9472LE 300LSE.
- 8 LAYOUTS ON SHEET 4
- 9. FOR COB-TO-HOLDER CROSS REFERENCE, REFER TO APPLICATION SPECIFICATION 114-32208
- 10 PACKAGED ONE TRAY OF 20 PCS PER BOX, 10 BOXES PER SHIPPING CARTON.

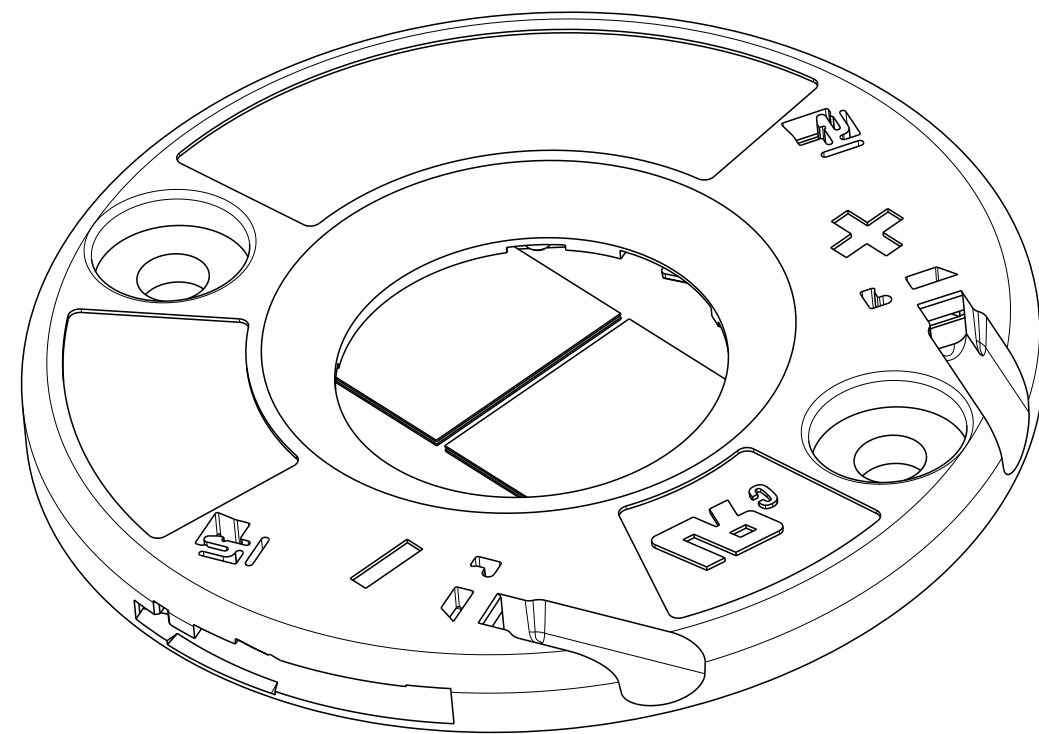

PAN HEAD
SCALE 3:1

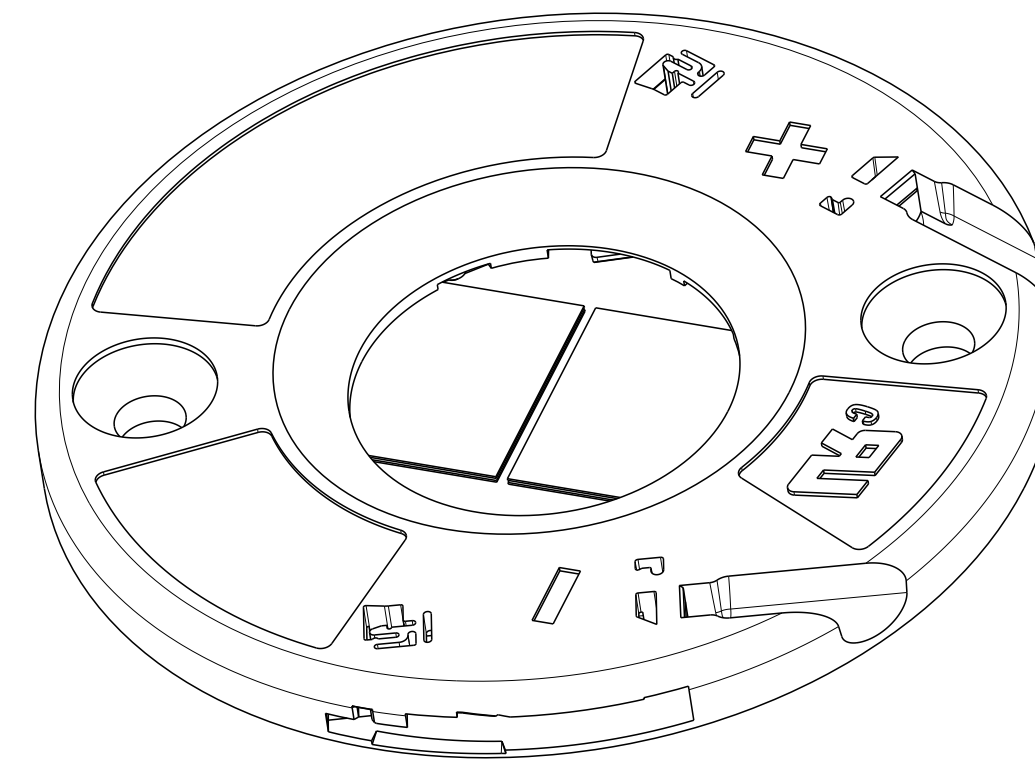

COUNTERSINK
SCALE 3:1

10	B	COUNTERSINK	5-2325807-3
	B	PAN HEAD	4-2325807-3
	A	PAN HEAD	4-2325807-2
	B	COUNTERSINK	1-2325807-3
	B	PAN HEAD	2325807-3
	A	COUNTERSINK	1-2325807-2
	A	PAN HEAD	2325807-2
	LED LAYOUT 8	DESCRIPTION	PART NO.

THIS DRAWING IS A CONTROLLED DOCUMENT.		DWN C. DAILY 18DEC2017	TE Connectivity	
		CHK J. LATORRE 18DEC2017		
DIMENSIONS:	TOLERANCES UNLESS OTHERWISE SPECIFIED:	APVD	NAME	LED HOLDER, 19x19 LUMAWISE Z45 LED
mm	0 PLC ± 1 PLC ±0.2 2 PLC ±0.13 3 PLC ± 4 PLC ±	PRODUCT SPEC	108-133062	
	ANGLES ±2°	APPLICATION SPEC	114-133107	
MATERIAL	FINISH	WEIGHT	SIZE	CAGE CODE
1	-	-	A2	00779
CUSTOMER DRAWING		SCALE	DRAWING NO	RESTRICTED TO
		2:1	C-2325807	-
		SHEET	REV	
		1 OF 4	B4	

THIS DRAWING IS UNPUBLISHED. RELEASED FOR PUBLICATION 20
 © COPYRIGHT 20 BY - ALL RIGHTS RESERVED.

REVISIONS				
P	LTR	DESCRIPTION	DATE	APVD
-	-	SEE SHEET 1	-	-

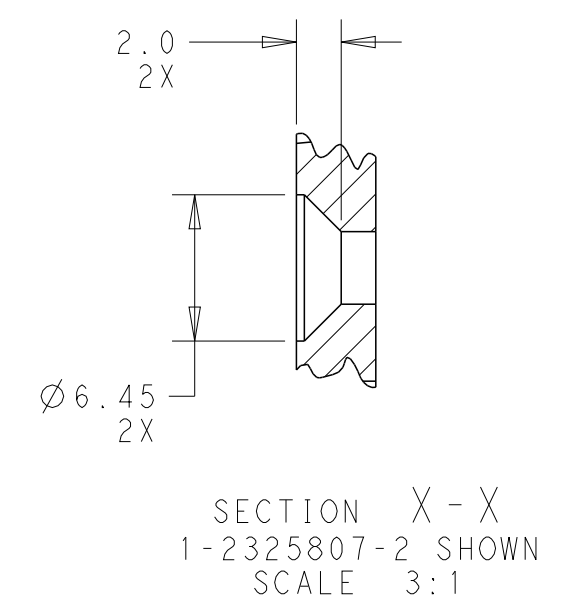
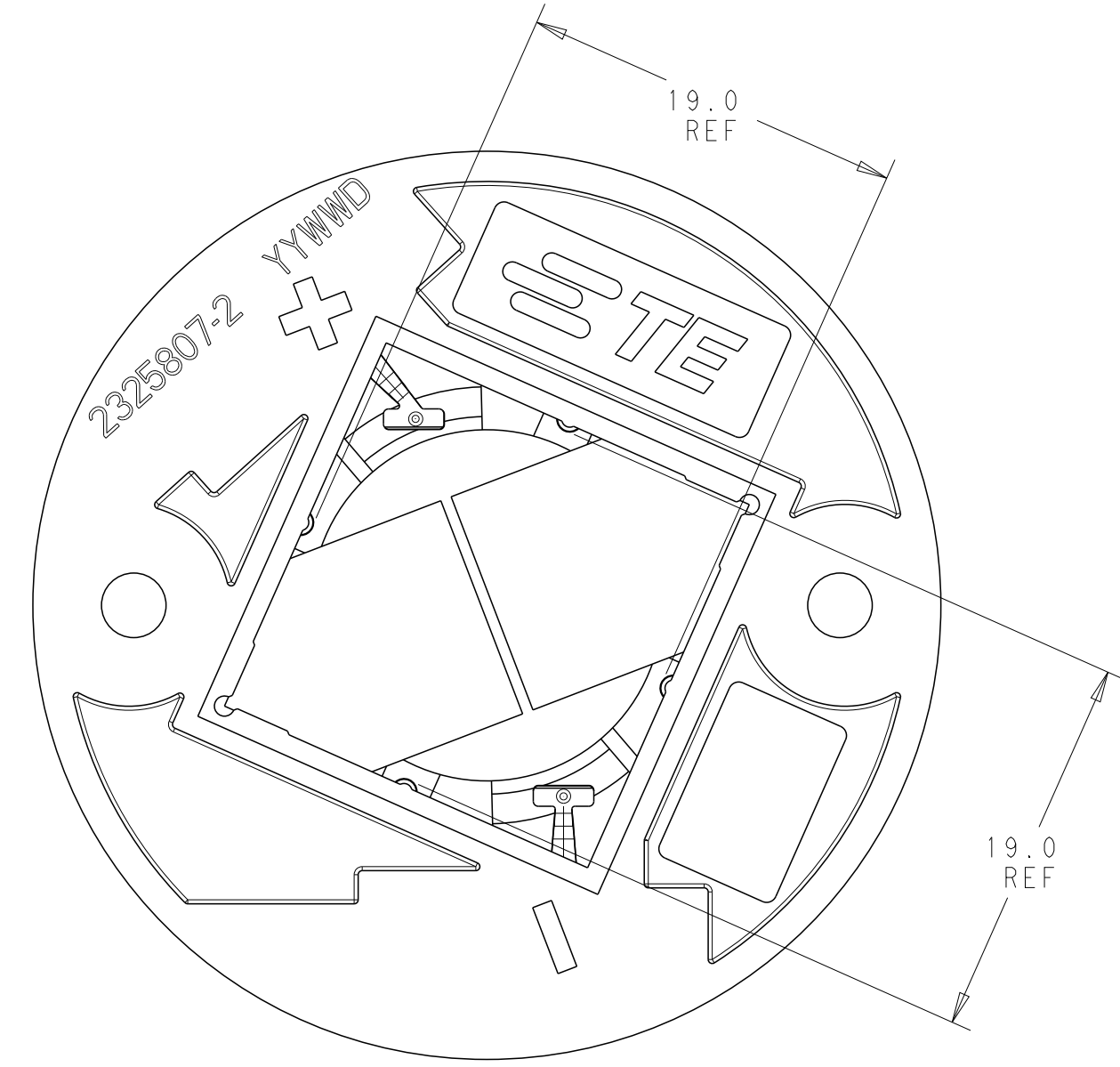
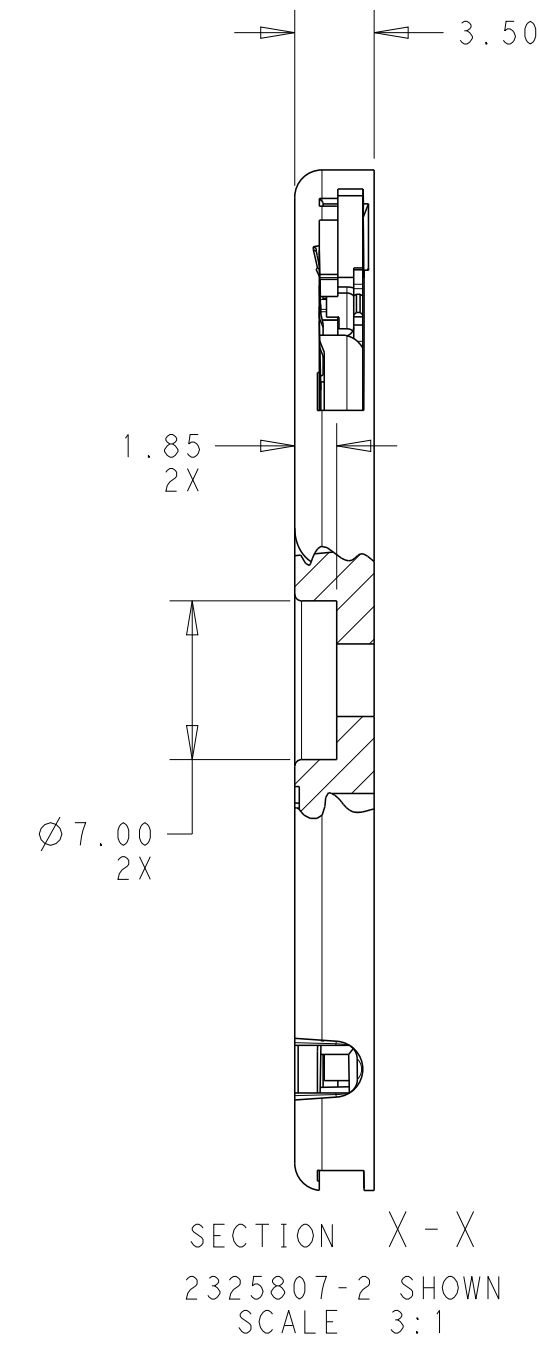
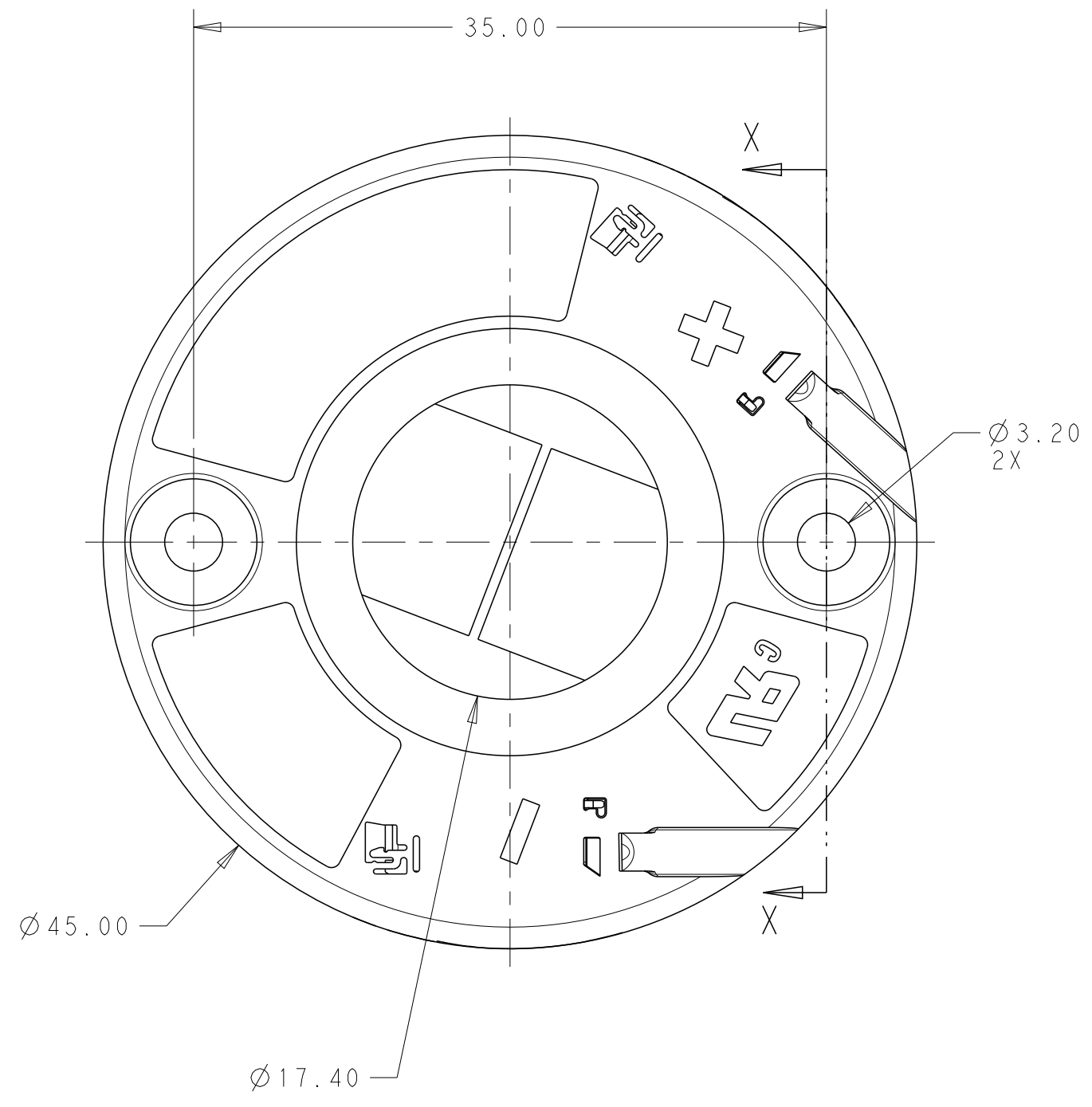

THIS DRAWING IS A CONTROLLED DOCUMENT.		DWN C. DAILY 18DEC2017	STE TE Connectivity	
		CHK J. LATORRE 18DEC2017		
DIMENSIONS:	TOLERANCES UNLESS OTHERWISE SPECIFIED:	APVD -	NAME LED HOLDER, 19x19 LUMAWISE Z45 LED	
mm	0 PLC ± 1 PLC ±0.2 2 PLC ±0.13 3 PLC ± 4 PLC ±	PRODUCT SPEC 108-133062	SIZE -	
	ANGLES ±2°	APPLICATION SPEC 114-133107	CAGE CODE A200779	DRAWING NO C-2325807
MATERIAL	FINISH -	WEIGHT -	RESTRICTED TO -	
		CUSTOMER DRAWING	SCALE 3:1	SHEET 2 OF 4
			REV B4	

THIS DRAWING IS UNPUBLISHED. RELEASED FOR PUBLICATION 20
 © COPYRIGHT 20 BY - ALL RIGHTS RESERVED.

REVISIONS				
P	LTR	DESCRIPTION	DATE	APVD
-	-	SEE SHEET 1	-	-

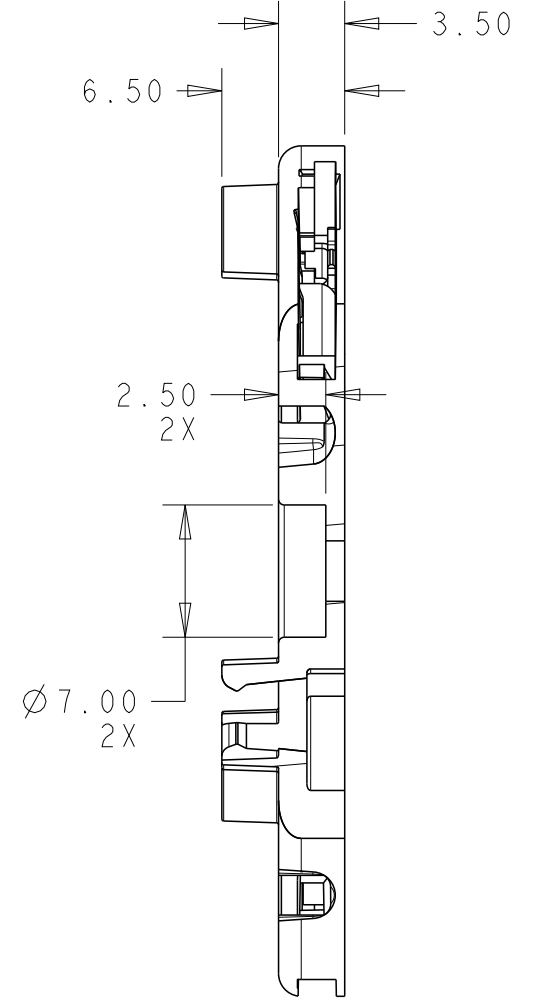
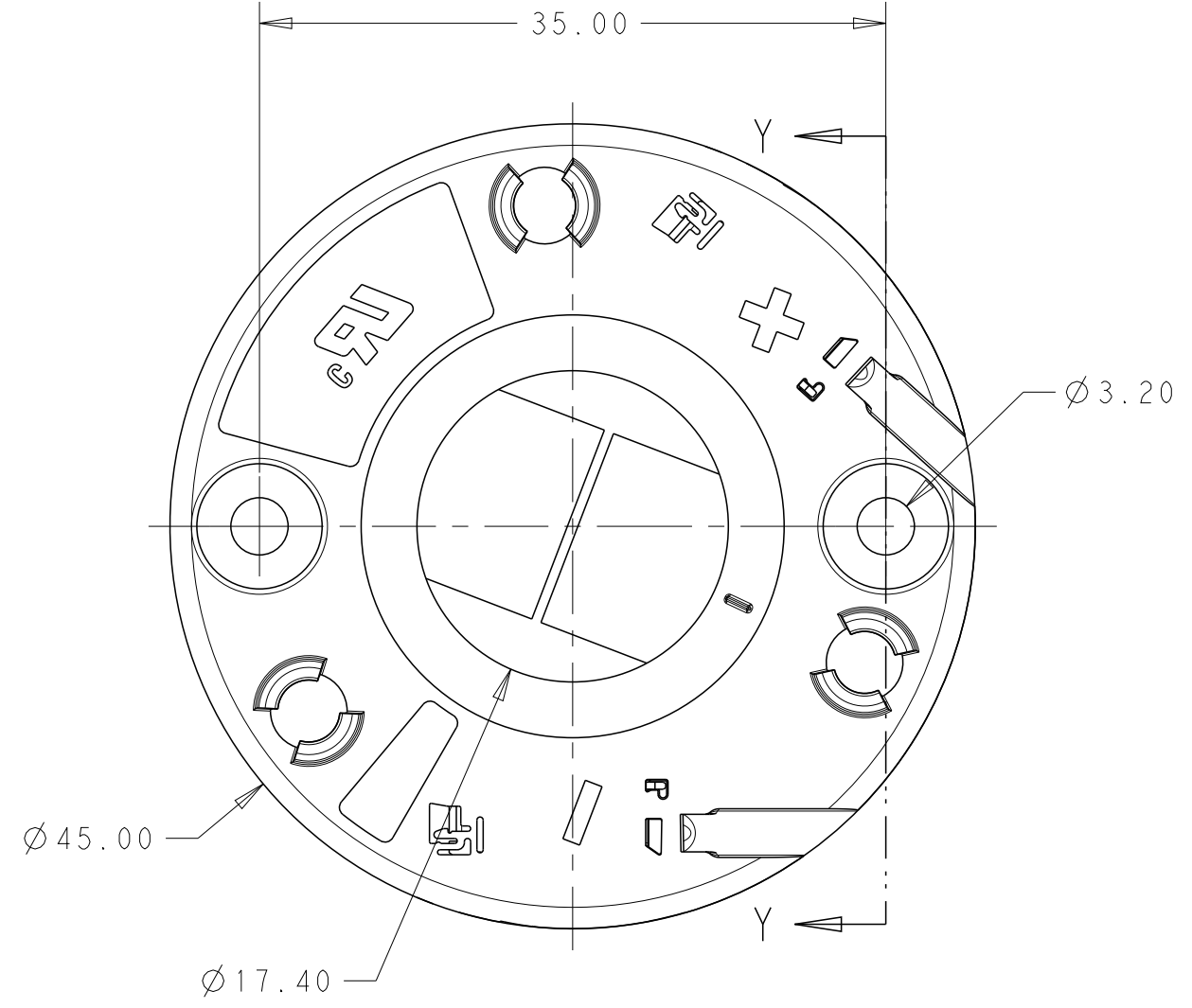

SECTION Y - Y
4-2325807-2 SHOWN

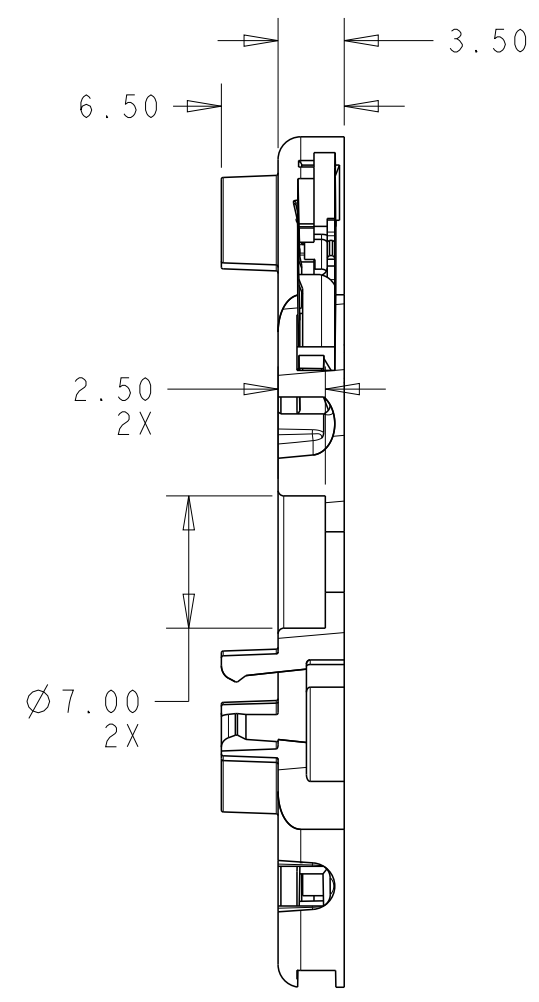
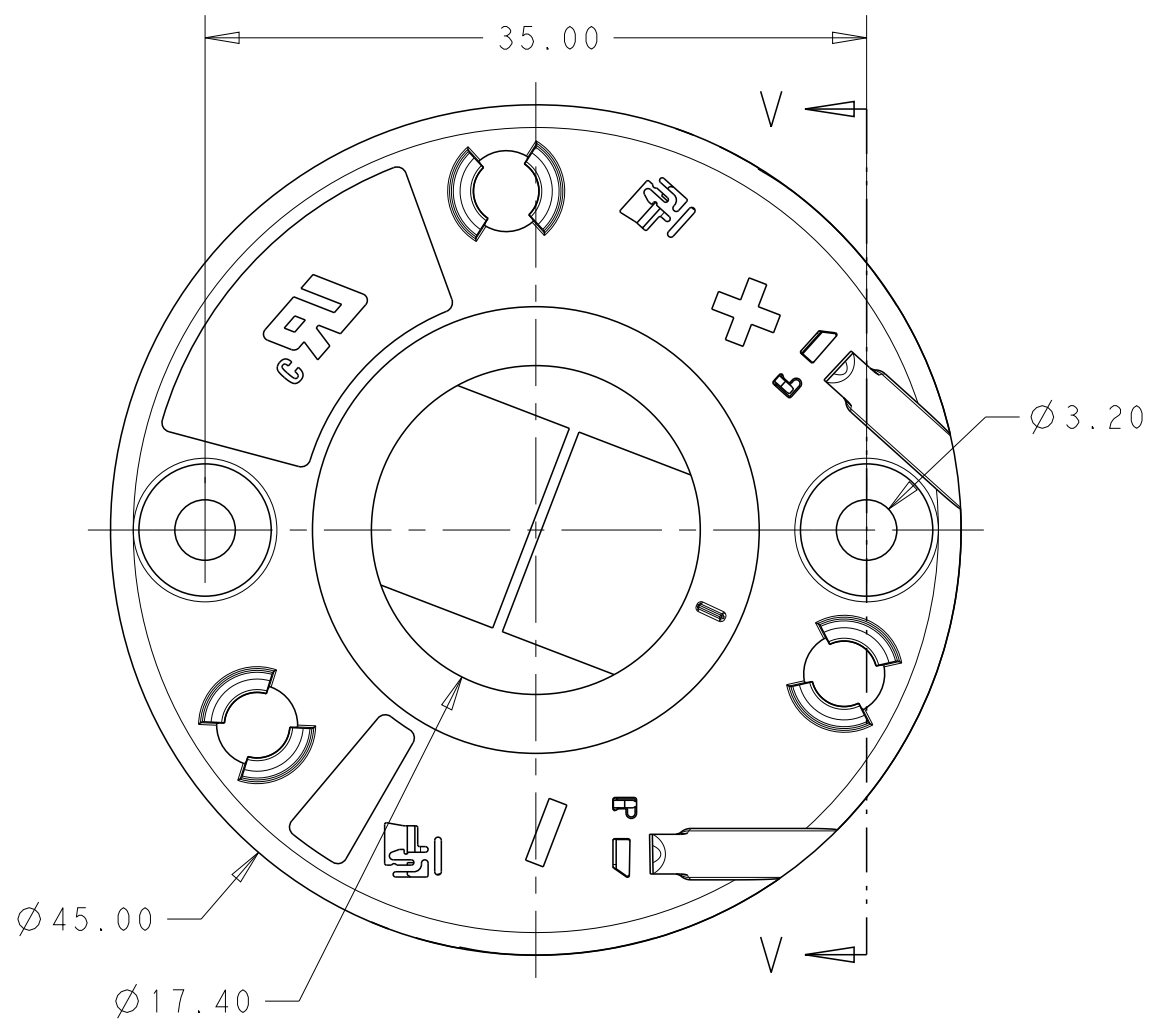
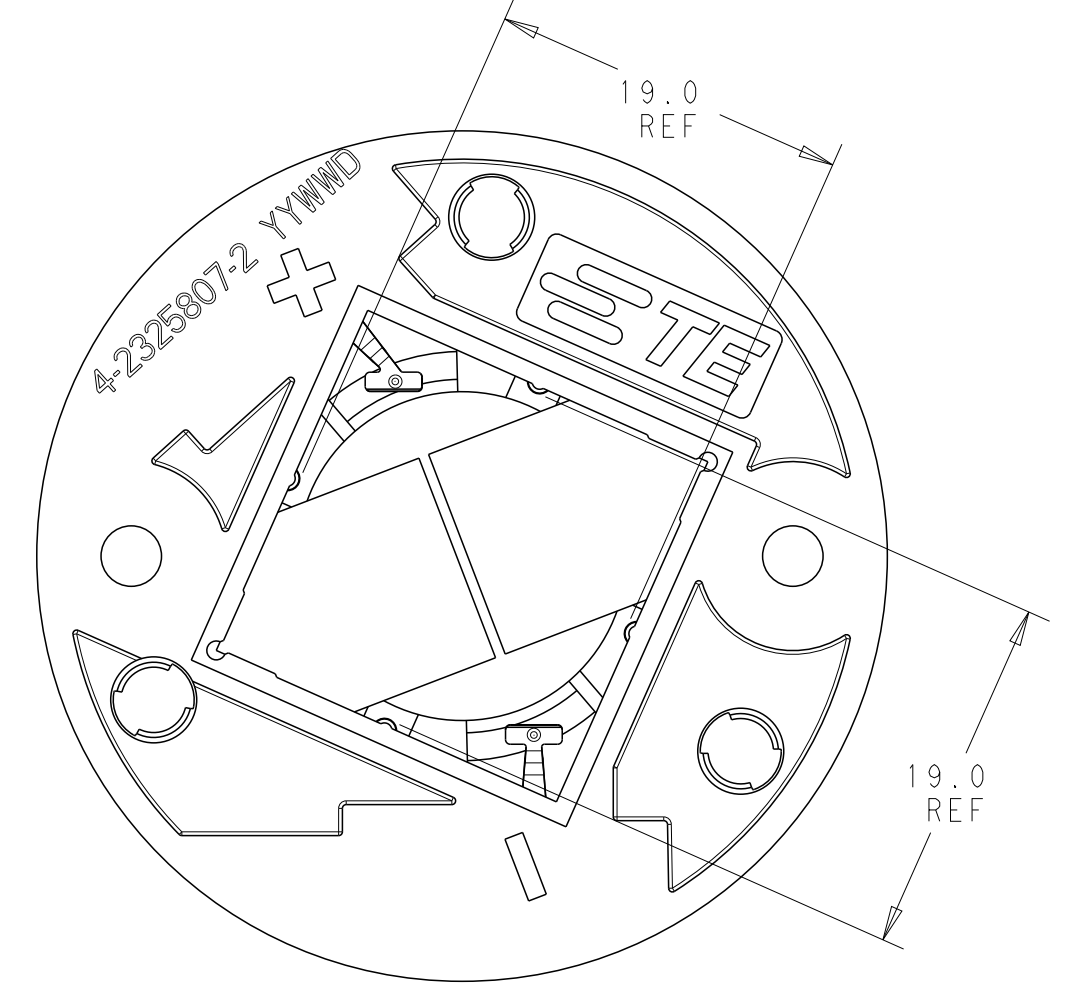

SECTION V - V
4-2325807-3 SHOWN

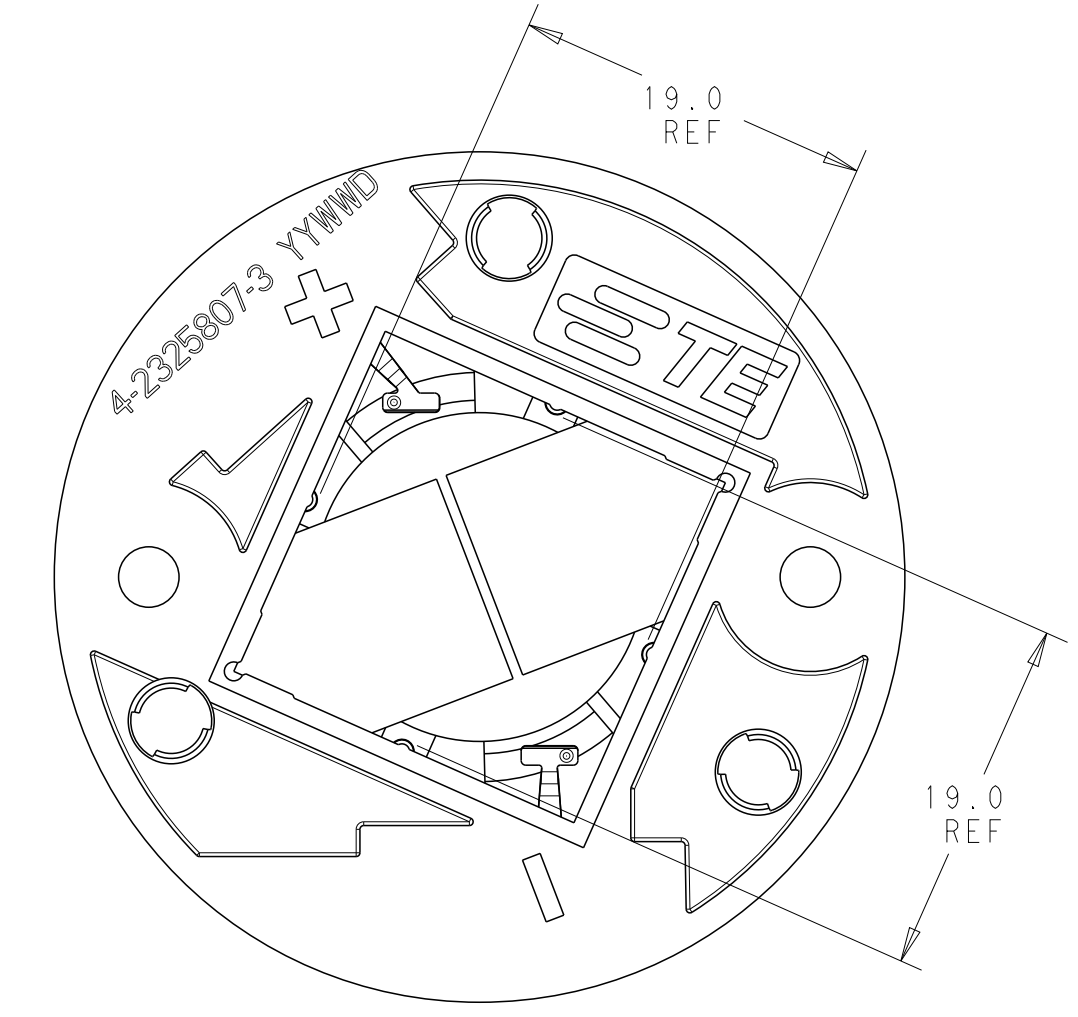

THIS DRAWING IS A CONTROLLED DOCUMENT.		DWN C. DAILY 18DEC2017	STE TE Connectivity	
		CHK J. LATORRE 18DEC2017		
DIMENSIONS:		APVD -	NAME LED HOLDER, 19x19 LUMAWISE Z45 LED	
mm	TOLERANCES UNLESS OTHERWISE SPECIFIED:	PRODUCT SPEC 108-133062	SIZE A200779	
	0 PLC ±	APPLICATION SPEC 114-133107	CAGE CODE C-2325807	DRAWING NO
	1 PLC ±0.2	WEIGHT -	RESTRICTED TO	
	2 PLC ±0.13	CUSTOMER DRAWING	SCALE 2:1	SHEET 3 OF 4
	3 PLC ±		REV B4	
	4 PLC ±			
	ANGLES ±2°			
	FINISH			