

THIS DRAWING IS UNPUBLISHED. RELEASED FOR PUBLICATION
 © COPYRIGHT copyright.d8te- ALL RIGHTS RESERVED.

REVISIONS				
P	LTR	DESCRIPTION	DATE	APVD
A		RELEASED PER ECN 21-105007	6-14-21	CT FB

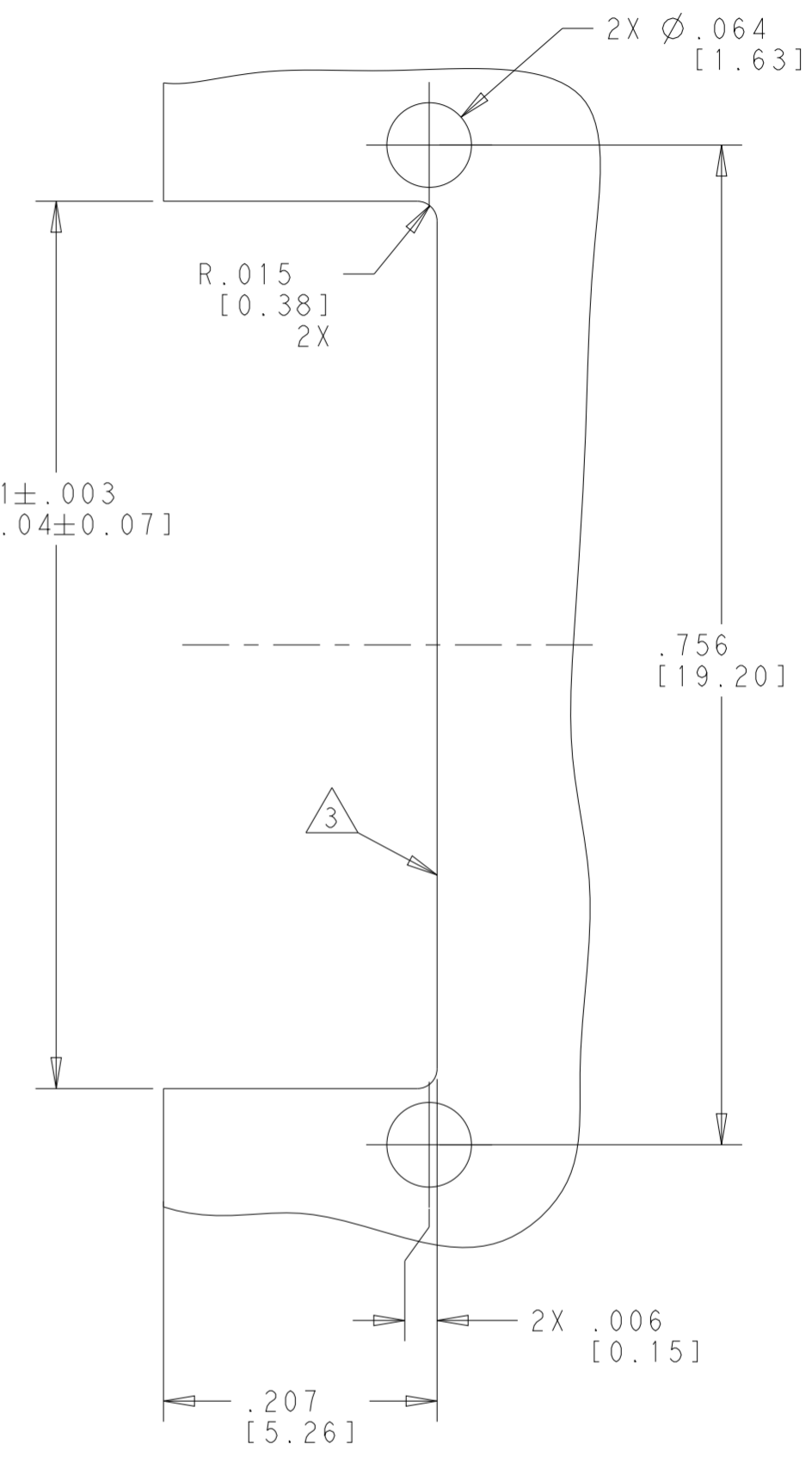
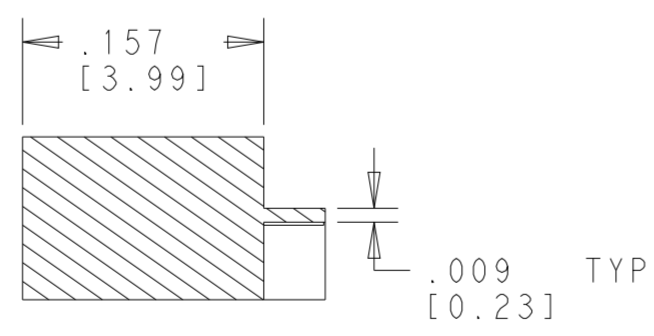
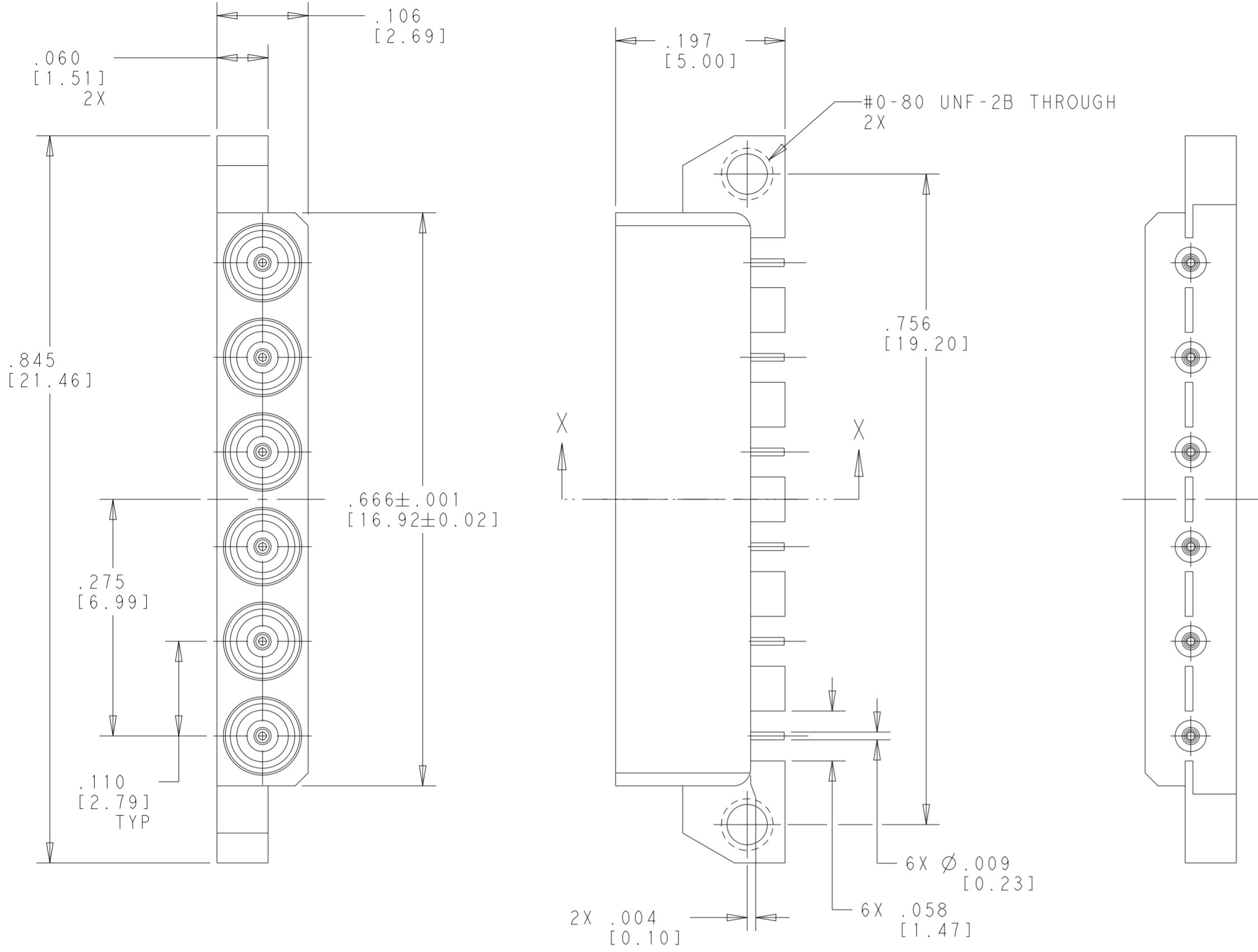

- 1 MATERIAL:
BODY AND CENTER CONTACT: COPPER ALLOY
INSULATOR: TEFLON (PTFE)
- 2 FINISH: FRONT BODY: 50-90 μIN GOLD PLATE OVER NICKEL
CENTER CONTACT: 35-70 μIN GOLD PLATE OVER NICKEL
REAR BODY: 3-15 μIN GOLD PLATE OVER NICKEL
- 3 CONNECTOR TO BE POSITIONED AGAINST THIS SURFACE PRIOR TO SOLDERING.

2337098-1
PART NO.

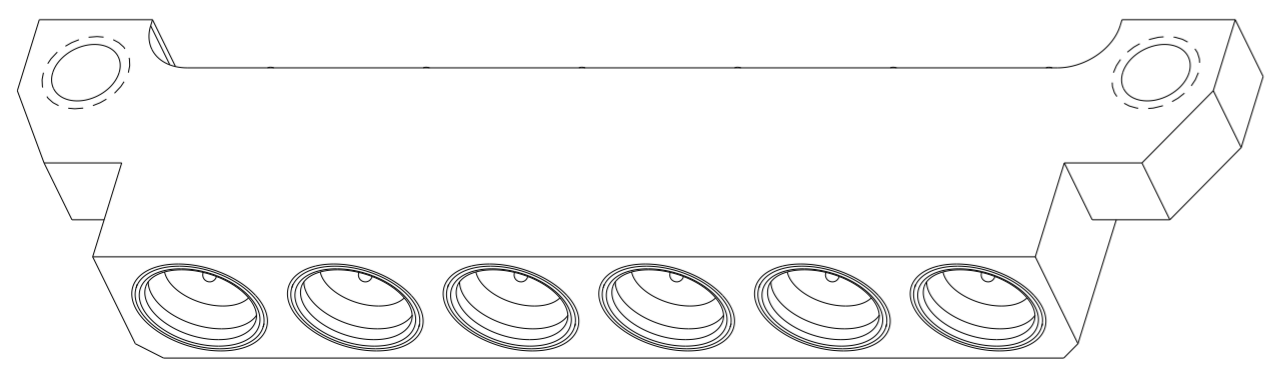

THIS DRAWING IS A CONTROLLED DOCUMENT.		DWN K. MILLER 05JUL2018	STE TE Connectivity	
DIMENSIONS: INCHES [mm]		CHK F. BLASICK 23JUL2018		
TOLERANCES UNLESS OTHERWISE SPECIFIED:		APVD F. BLASICK 23JUL2018	NAME SMPS EDGE LAUNCH, 6 POSITION .110 CENTERLINE SPACING	
0 PLC ±	1 PLC ±	PRODUCT SPEC	SIZE	RESTRICTED TO
2 PLC ±	3 PLC ±.005(0.13)	APPLICATION SPEC	CAGE CODE	OF 1
4 PLC ±	ANGLES ±	FINISH	DRAWING NO	REV A
MATERIAL	1	WEIGHT	A200779	SCALE 8:1
CUSTOMER DRAWING		C-2337098		SHEET 1 OF 1