

THIS DRAWING IS UNPUBLISHED. RELEASED FOR PUBLICATION 20  
 © COPYRIGHT 20 BY - ALL RIGHTS RESERVED.

REVISIONS				
P	LTR	DESCRIPTION	DATE	APVD
A		PRODUCTION RELEASE	13JUN2019	JW SH
A1		REVISED PER ECN-21-123572	14OCT2021	SH SZ

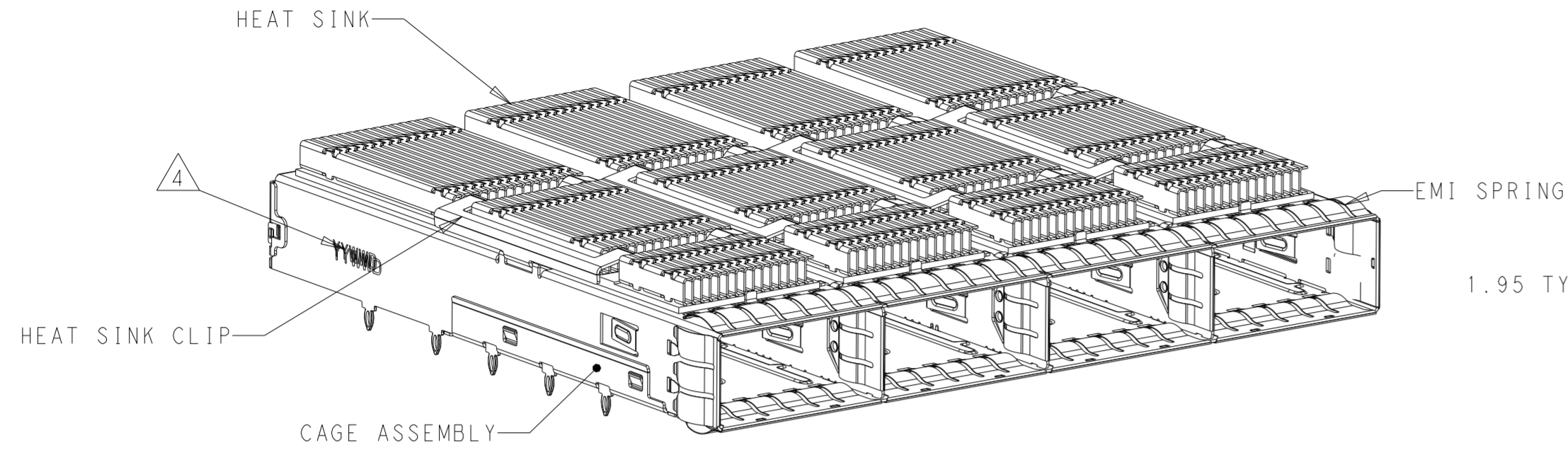

2343989-1 AS SHOWN

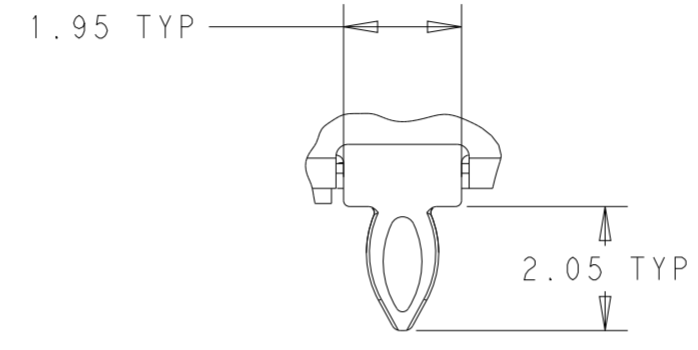

DETAIL A  
SCALE 8:1

- 1 CAGE ASSEMBLY: STAINLESS STEEL.  
HEAT SINK: ALUMINUM/NICKEL PLATE.  
HEAT SINK CLIP: STAINLESS STEEL.  
EMI SPRING: COPPER ALLOY/NICKEL PLATE.
- 2 REFERENCE APPLICATION SPECIFICATION 114-32023 FOR RECOMMENDED DRILL HOLE DIAMETER AND PLATING THICKNESS. BOARD LAYOUT PER THIS PRINT.
- 3 DATUM AND BASIC DIMENSION ESTABLISHED BY CUSTOMER.
- 4 DATE CODE (YYWW) MARKED APPROXIMATELY AS SHOWN.
- 5. MATES WITH QSFP DD MSA COMPATIBLE TRANSCEIVER.
- 6. MINIMUM PC BOARD THICKNESS: SINGLE SIDED: 1.45 MIN  
DOUBLE SIDED: 2.20 MIN
- 7 ONLY FOR VERSION WITH REAR EONS

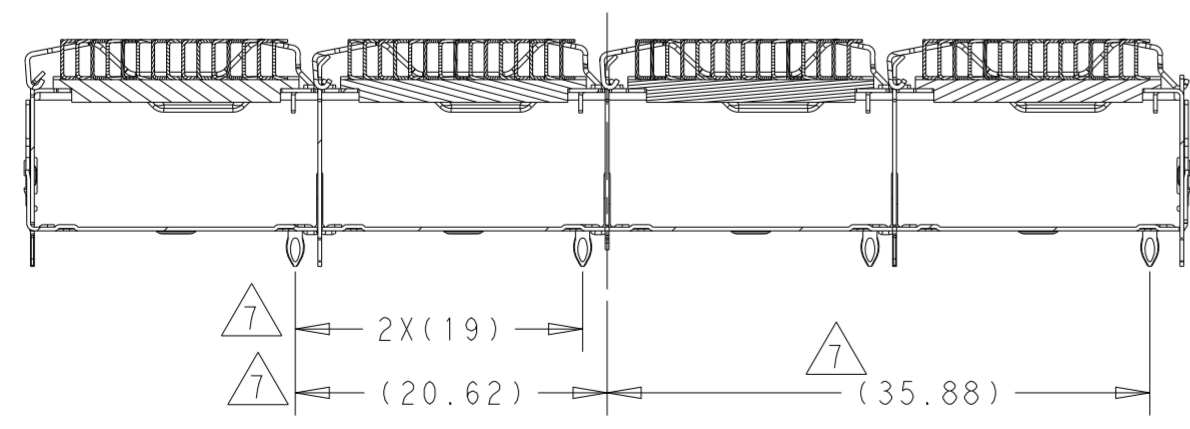
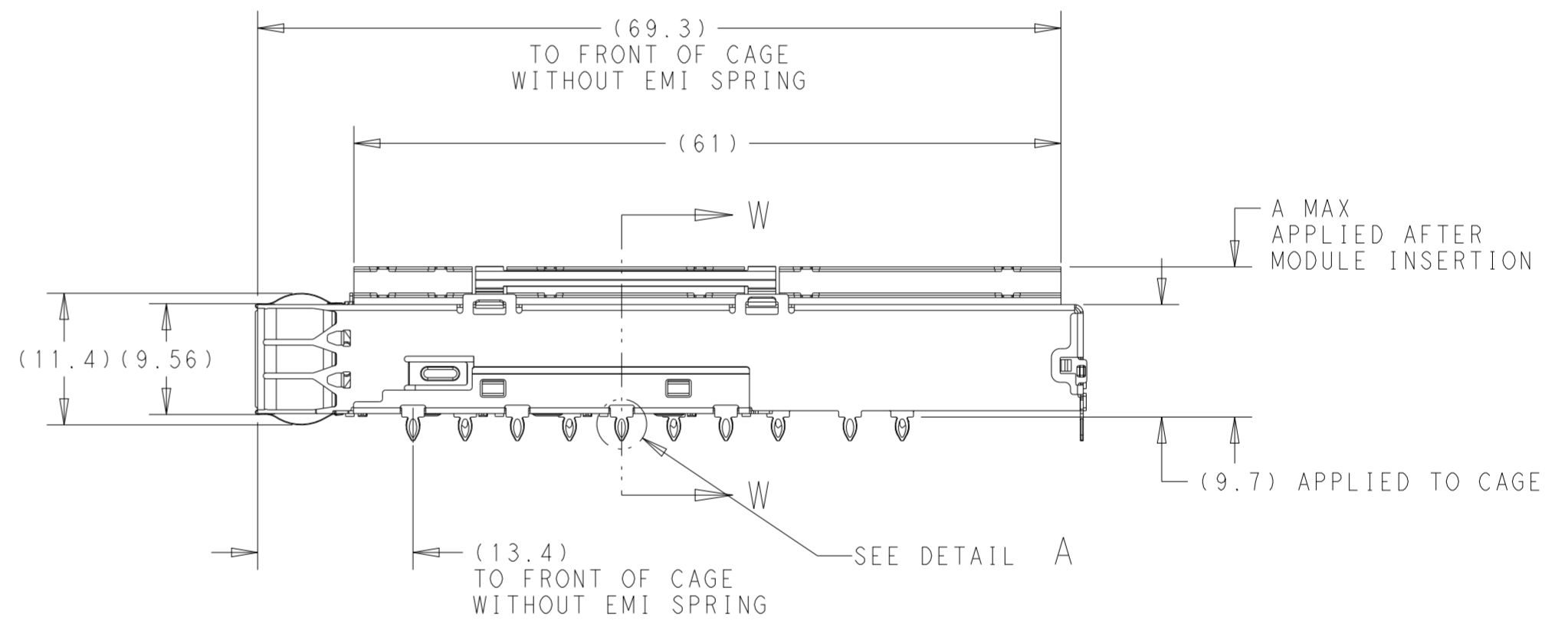
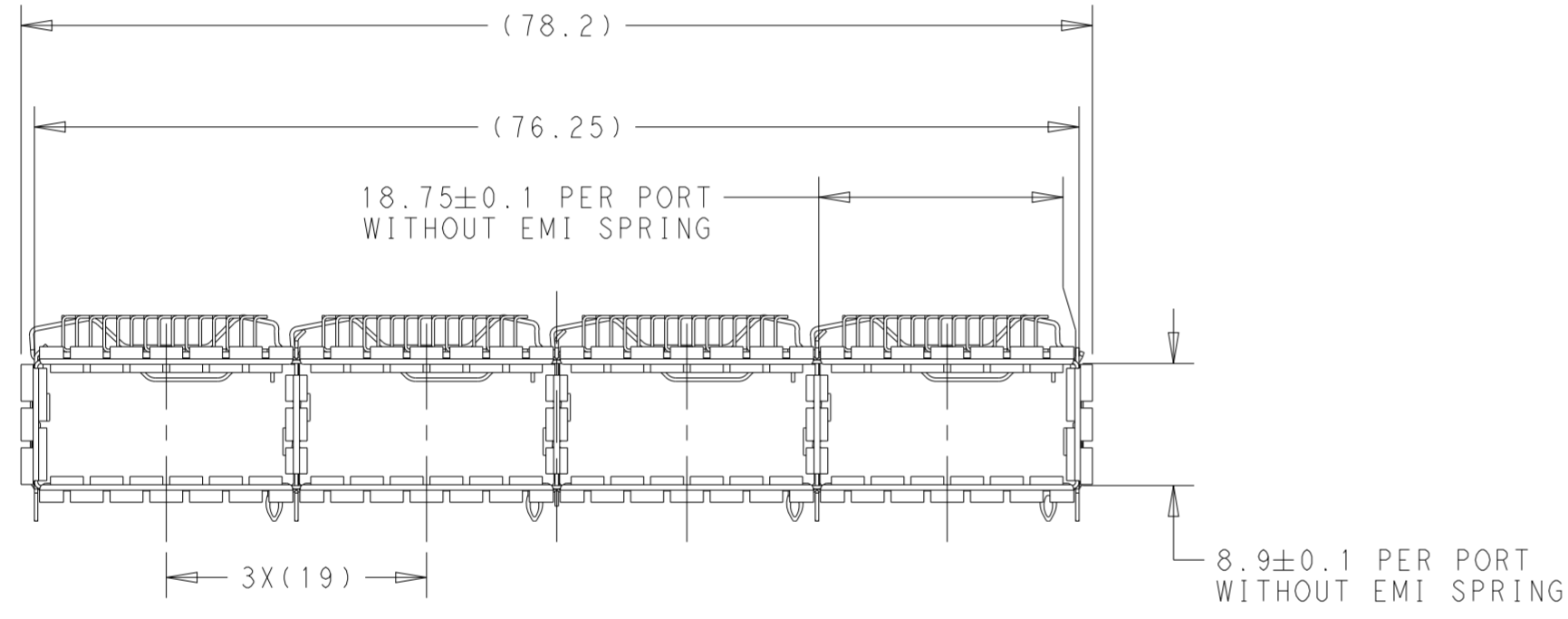

For 2343989-1/-2-3 WITH REAR EONS  
SECTION W-W

VERSION	DIM A	PART NUMBER
W REAR EONS	15.5	2343989-7
W/O REAR EONS	23	1-2343989-3
W/O REAR EONS	16	1-2343989-2
W/O REAR EONS	13.7	1-2343989-1
W REAR EONS	19.75	2343989-6
W REAR EONS	15.55	2343989-5
W REAR EONS	23	2343989-3
W REAR EONS	16	2343989-2
W REAR EONS	13.7	2343989-1

THIS DRAWING IS A CONTROLLED DOCUMENT.		DWN J. WANG 10OCT2018	TE Connectivity	
DIMENSIONS: mm		CHK S. HAN 10OCT2018		
TOLERANCES UNLESS OTHERWISE SPECIFIED:		APVD S. HAN 10OCT2018	NAME CAGE WITH HEATSINK THRU BEZEL, 1X4, QSFP DD	
0 PLC ±0.25	1 PLC ±0.25	PRODUCT SPEC	SIZE CAGE CODE DRAWING NO RESTRICTED TO	
2 PLC ±0.25	3 PLC ±	APPLICATION SPEC	A2 - C-2343989	
4 PLC ±	ANGLES ±	WEIGHT	SCALE 2:1 SHEET 1 OF 7 REV A1	
FINISH		CUSTOMER DRAWING		

THIS DRAWING IS UNPUBLISHED. RELEASED FOR PUBLICATION 20  
 © COPYRIGHT 20 BY - ALL RIGHTS RESERVED.

REVISIONS				
P	LTR	DESCRIPTION	DATE	APVD
-		SEE SHEET 1	-	-

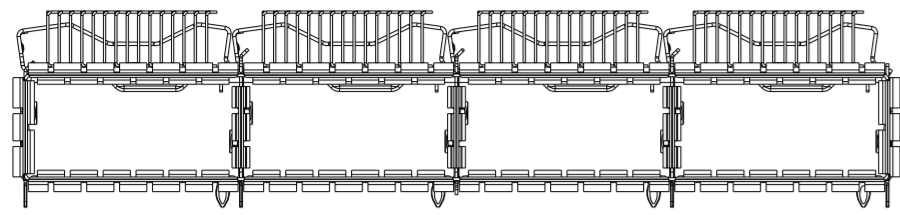

2343989-2  
 UNMARKED DIMENSIONS SAME AS 2343989-1  
 SCALE 3:2

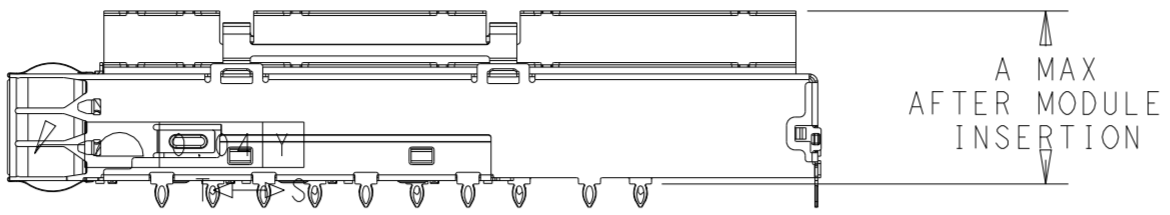

A MAX  
 AFTER MODULE  
 INSERTION

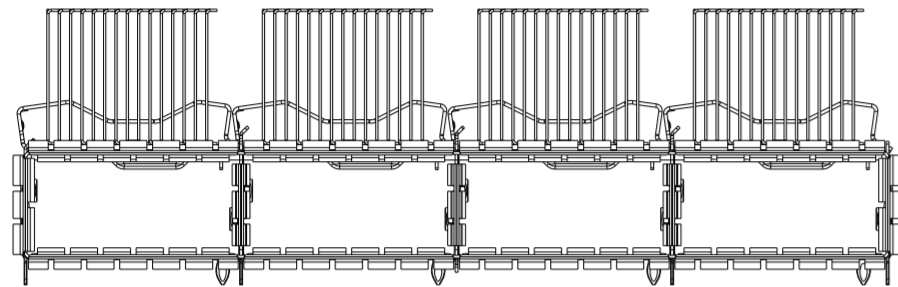
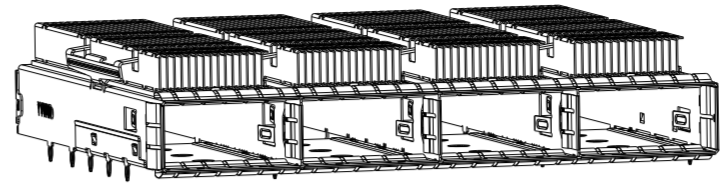

2343989-3  
 UNMARKED DIMENSIONS SAME AS 2343989-1  
 SCALE 3:2

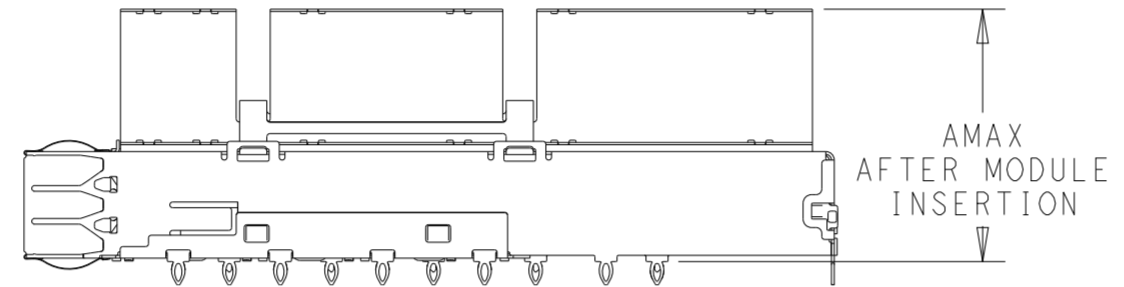

A MAX  
 AFTER MODULE  
 INSERTION

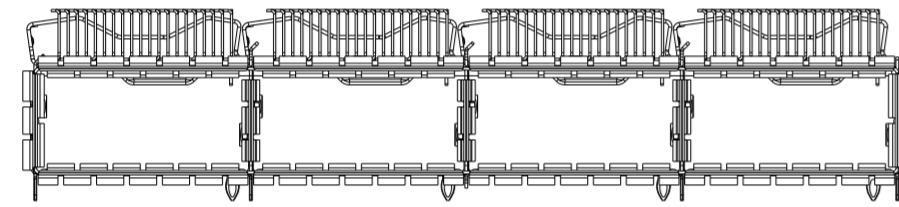
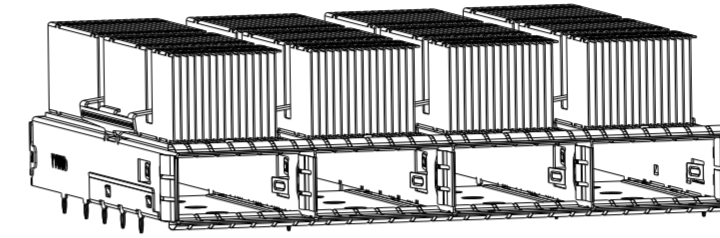

2343989-5  
 UNMARKED DIMENSIONS SAME AS 2343989-3  
 SCALE 3:2

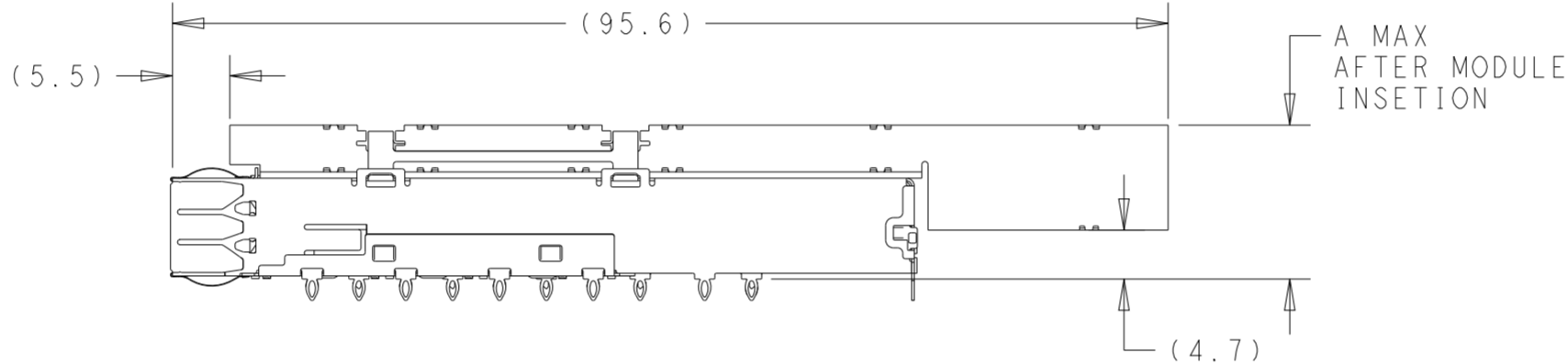

A MAX  
 AFTER MODULE  
 INSERTION

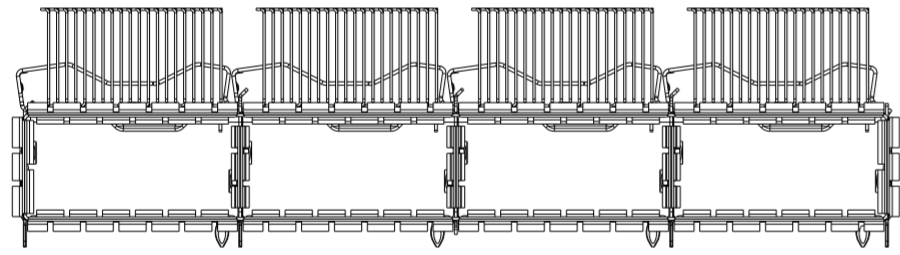
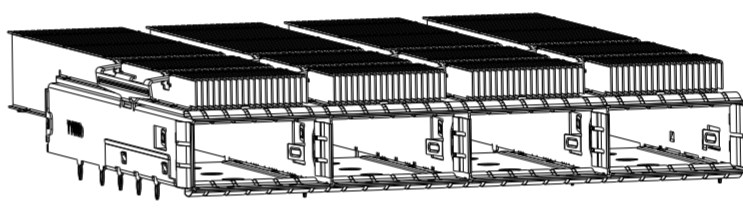

2343989-6  
 UNMARKED DIMENSIONS SAME AS 2343989-3  
 SCALE 3:2

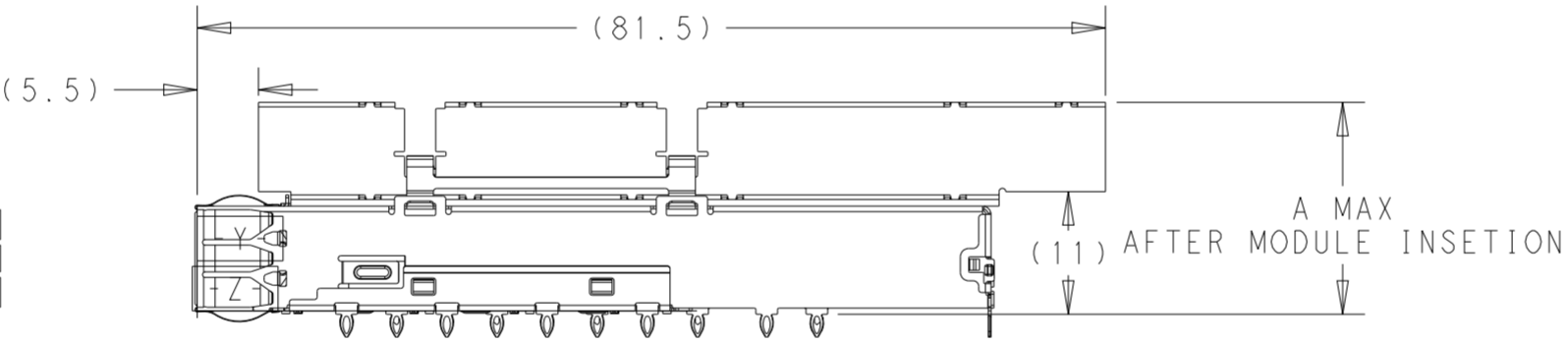

A MAX  
 AFTER MODULE  
 INSERTION

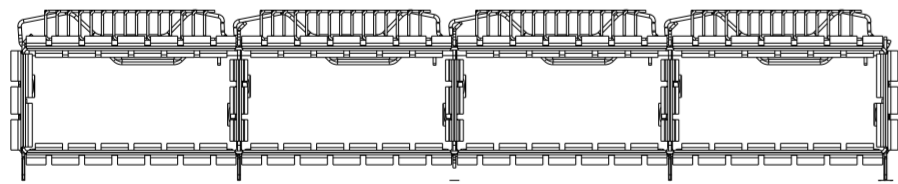
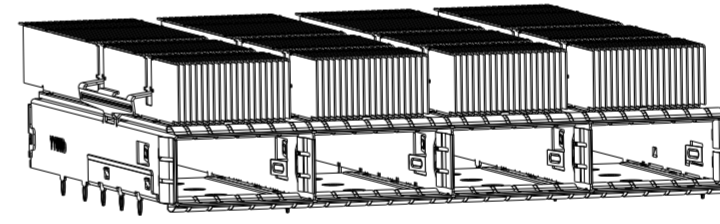

1-2343989-1  
 WITHOUT REAR EONS  
 UNMARKED DIMENSIONS SAME AS 2343989-1  
 SCALE 3:2

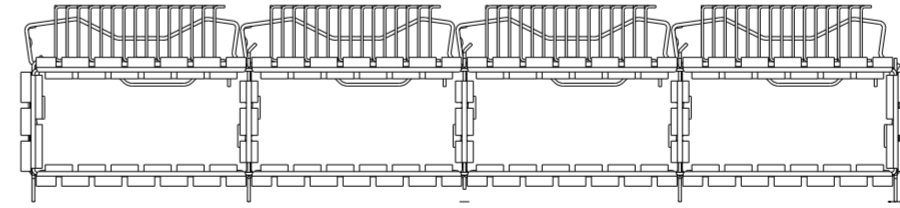
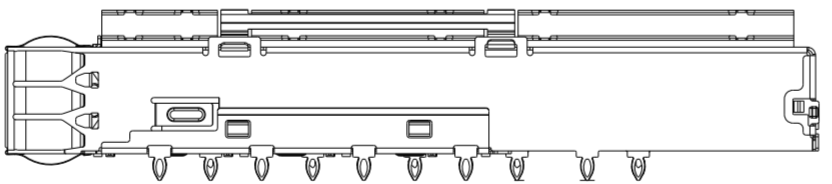

1-2343989-2  
 WITHOUT REAR EONS  
 UNMARKED DIMENSIONS SAME AS 2343989-2  
 SCALE 3:2

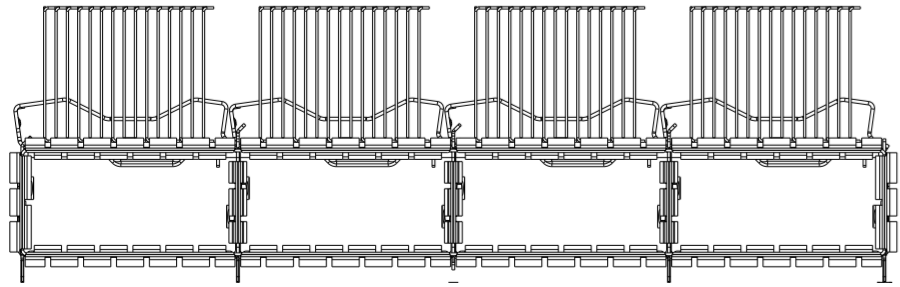
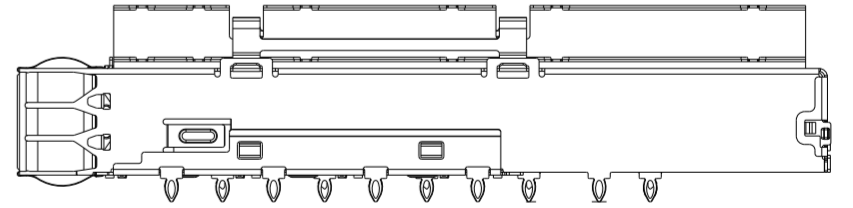

1-2343989-3  
 WITHOUT REAR EONS  
 UNMARKED DIMENSIONS SAME AS 2343989-3  
 SCALE 3:2

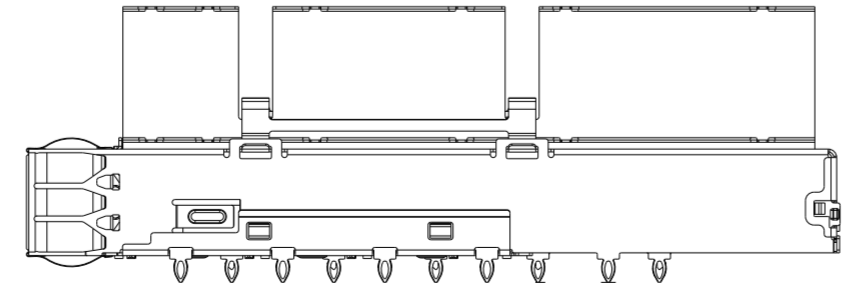

THIS DRAWING IS A CONTROLLED DOCUMENT.		DWN J. WANG 10OCT2018	TE Connectivity
DIMENSIONS:		CHK S. HAN 10OCT2018	
TOLERANCES UNLESS OTHERWISE SPECIFIED:		APVD S. HAN 10OCT2018	
mm		PRODUCT SPEC	
0 PLC ±0.25 1 PLC ±0.25 2 PLC ±0.25 3 PLC ± 4 PLC ± ANGLES ± FINISH ±		APPLICATION SPEC	NAME CAGE WITH HEATSINK THRU BEZEL, 1X4, QSFP DD
MATERIAL	-	WEIGHT	SIZE A2
-		CUSTOMER DRAWING	CAGE CODE -
		SCALE 2:1	DRAWING NO C-2343989
		SHEET 2 OF 7	RESTRICTED TO -
		REV A1	

THIS DRAWING IS UNPUBLISHED. RELEASED FOR PUBLICATION 20  
 © COPYRIGHT 20 BY - ALL RIGHTS RESERVED.

REVISIONS				
P	LTR	DESCRIPTION	DATE	APVD
-		SEE SHEET 1	-	-

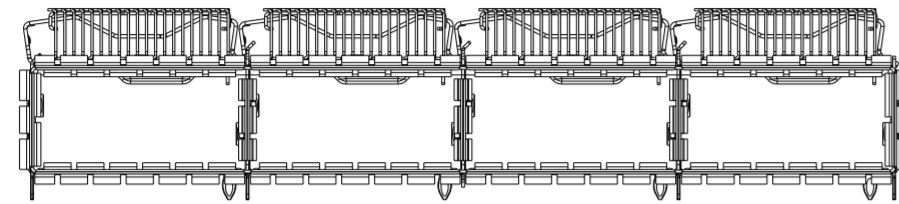

2343989-7 AS SHOWN  
 SAME AS -1 EXCEPT HEAT SINK  
 SCALE 3:2

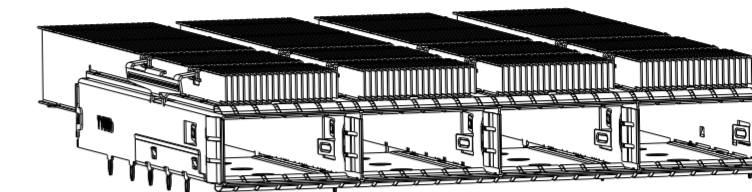
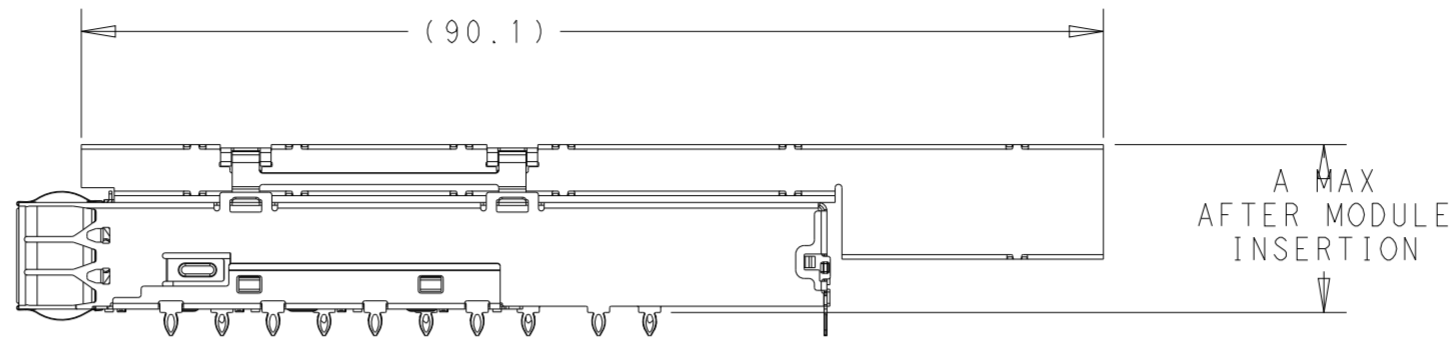

THIS DRAWING IS A CONTROLLED DOCUMENT.		DWN J. WANG	10OCT2018	 TE Connectivity	
DIMENSIONS: mm		CHK S. HAN	10OCT2018		
TOLERANCES UNLESS OTHERWISE SPECIFIED:		APVD S. HAN	10OCT2018	NAME CAGE WITH HEATSINK THRU BEZEL, 1X4, QSFP DD	
0 PLC ±0.25 1 PLC ±0.25 2 PLC ±0.25 3 PLC ± 4 PLC ± ANGLES ± FINISH ±		PRODUCT SPEC -		RESTRICTED TO -	
MATERIAL -		APPLICATION SPEC -		SIZE A2	CAGE CODE -
		WEIGHT -		DRAWING NO C-2343989	
		CUSTOMER DRAWING		SCALE 2:1	SHEET 3 OF 7
				REV A1	

THIS DRAWING IS UNPUBLISHED. RELEASED FOR PUBLICATION 20  
 © COPYRIGHT 20 BY - ALL RIGHTS RESERVED.

REVISIONS				
P	LTR	DESCRIPTION	DATE	APVD
-	-	SEE SHEET 1	-	-

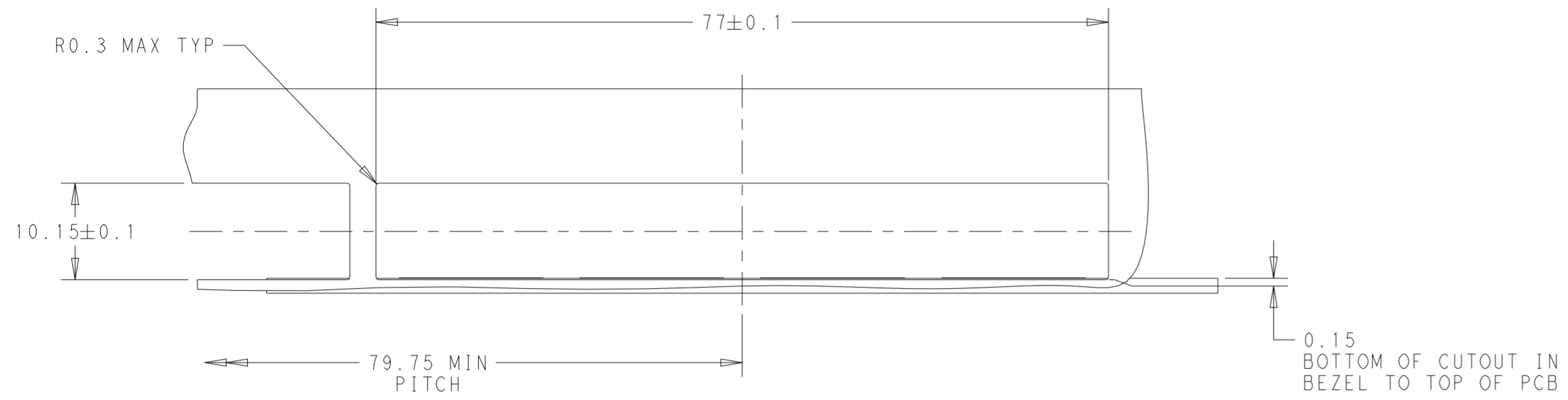

CAGE ASSEMBLY OMITTED FOR CLARITY

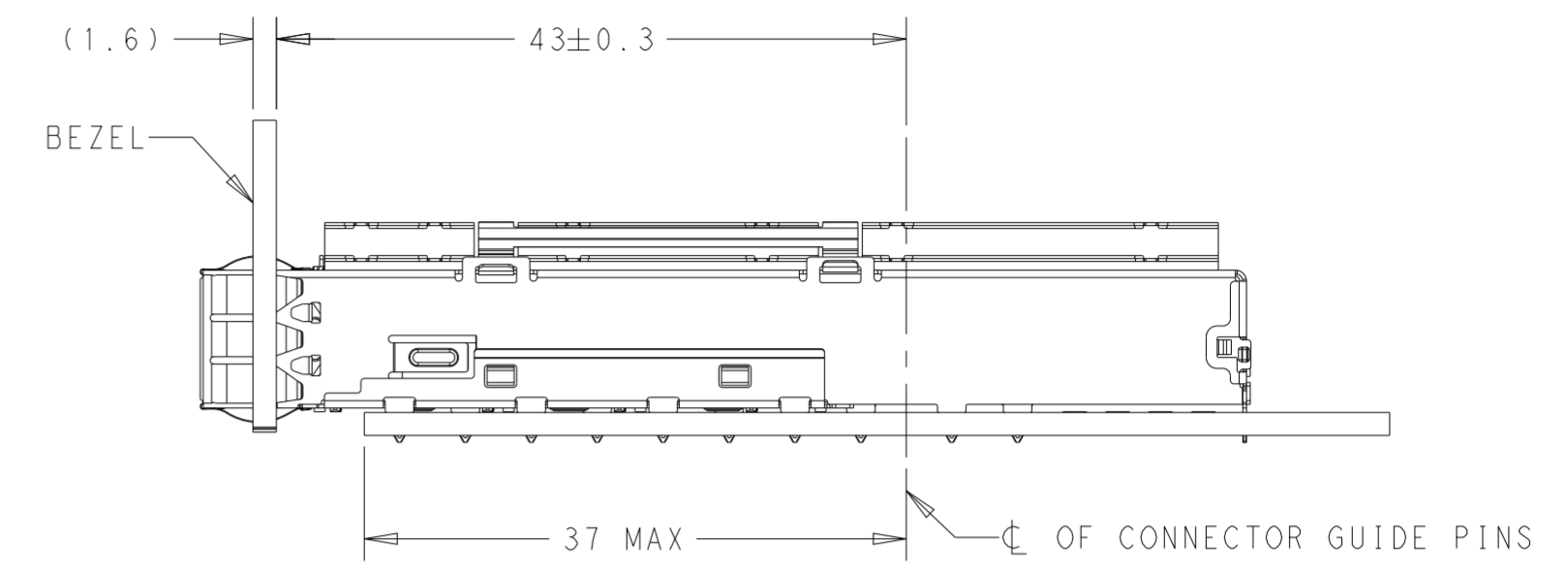

SINGLE SIDE MOUNTING

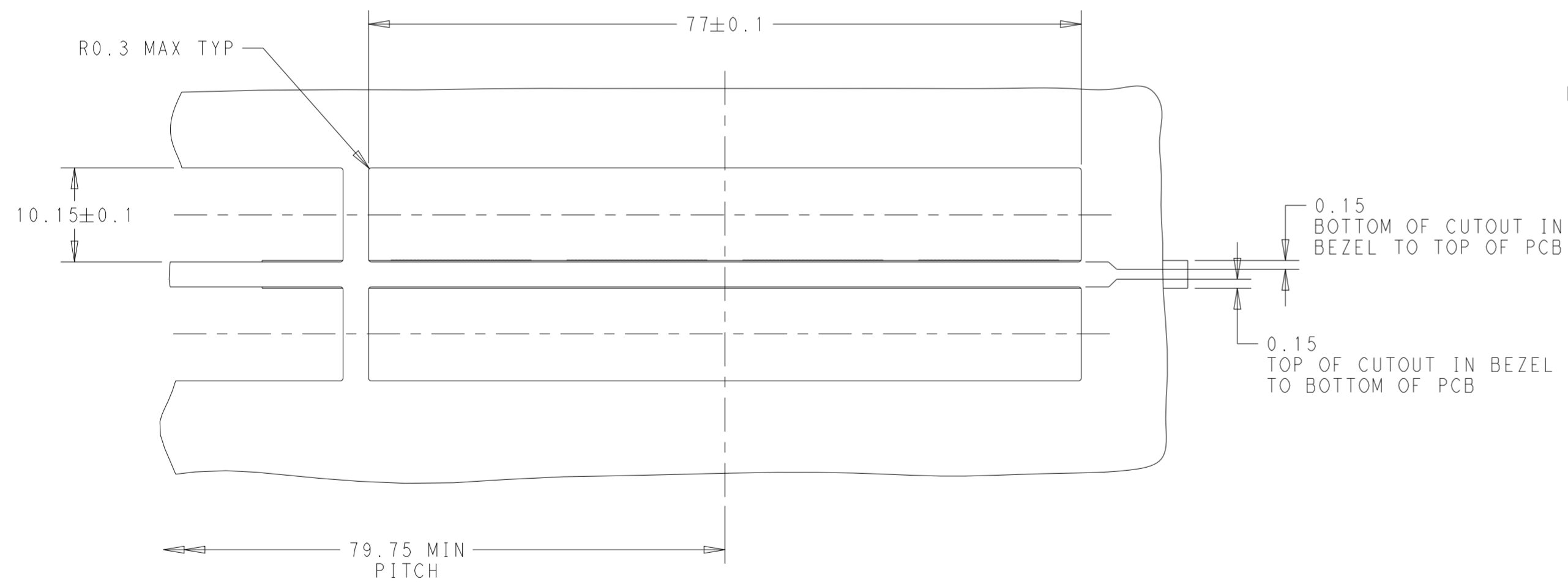

CAGE ASSEMBLY OMITTED FOR CLARITY

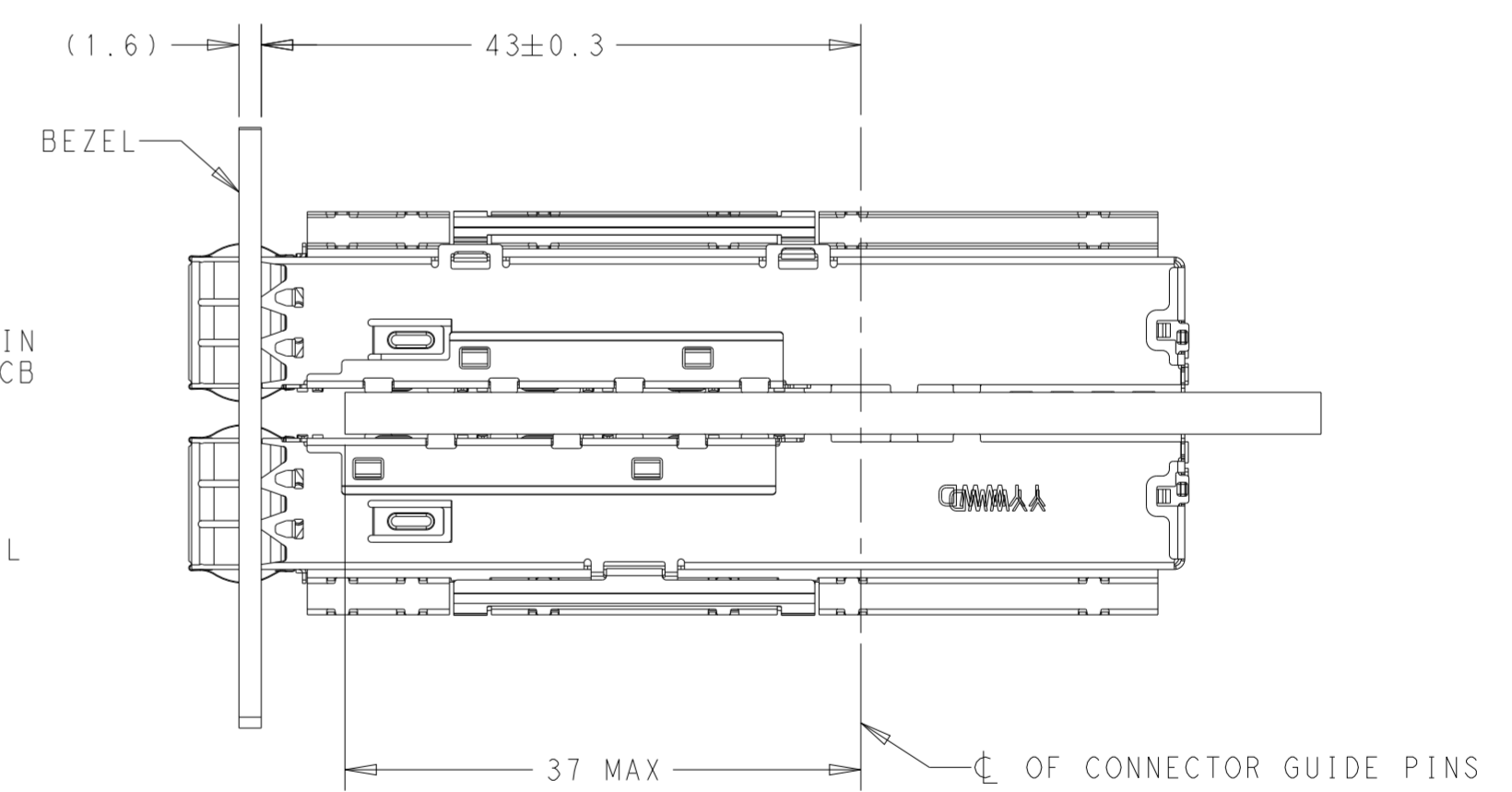

BELLY TO BELLY MOUNTING

THIS DRAWING IS A CONTROLLED DOCUMENT.		DWN J. WANG 10OCT2018	TE Connectivity	
DIMENSIONS: mm		CHK S. HAN 10OCT2018		
TOLERANCES UNLESS OTHERWISE SPECIFIED:		APVD S. HAN 10OCT2018	NAME CAGE WITH HEATSINK THRU BEZEL, 1X4, QSFP DD	
		PRODUCT SPEC -	SIZE A2	
MATERIAL -		APPLICATION SPEC -	CAGE CODE -	DRAWING NO. C-2343989
FINISH -		WEIGHT -	RESTRICTED TO -	SCALE 2:1
-		CUSTOMER DRAWING	SHEET 4 OF 7	REV A1

REVISIONS				
P	LTR	DESCRIPTION	DATE	APVD
-	-	SEE SHEET 1	-	-

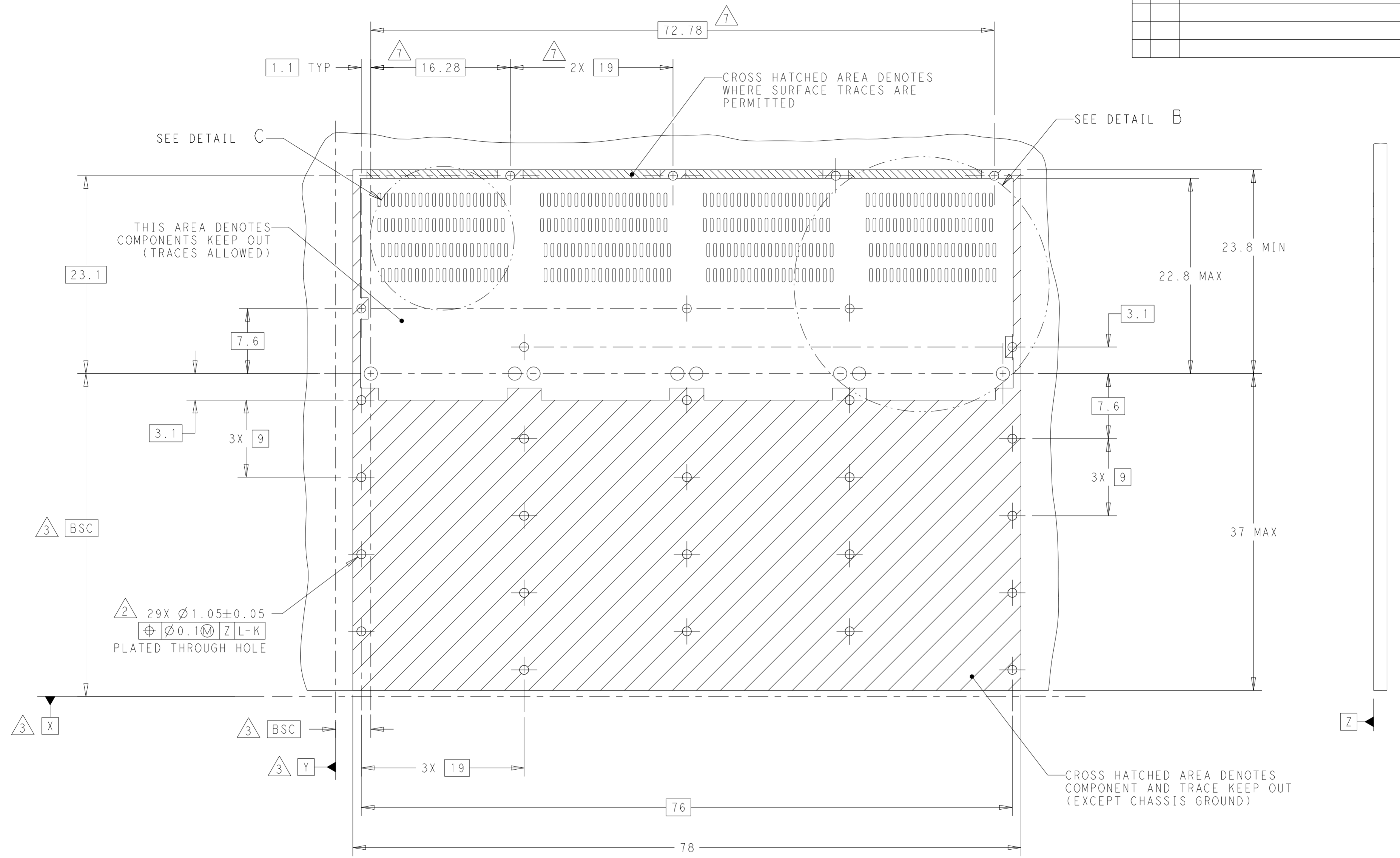

RECOMMENDED PCB LAYOUT  
 SINGLE TYPE  
 SCALE 3:1

THIS DRAWING IS A CONTROLLED DOCUMENT.		DWN J. WANG	10OCT2018	 TE Connectivity	NAME CAGE WITH HEATSINK THRU BEZEL, 1X4, QSFP DD
DIMENSIONS: mm		CHK S. HAN	10OCT2018		
		APVD S. HAN	10OCT2018		
TOLERANCES UNLESS OTHERWISE SPECIFIED:		PRODUCT SPEC		APPLICATION SPEC	RESTRICTED TO
0 PLC ±0.25 1 PLC ±0.25 2 PLC ±0.25 3 PLC ± 4 PLC ± ANGLES ± FINISH ±		WEIGHT		SIZE A2	CAGE CODE -
MATERIAL		CUSTOMER DRAWING		DRAWING NO C-2343989	SCALE 2:1
				SHEET 5 OF 7	REV A1

THIS DRAWING IS UNPUBLISHED. RELEASED FOR PUBLICATION 20  
 © COPYRIGHT 20 BY - ALL RIGHTS RESERVED.

REVISIONS				
P	LTR	DESCRIPTION	DATE	APVD
-	-	SEE SHEET 1	-	-

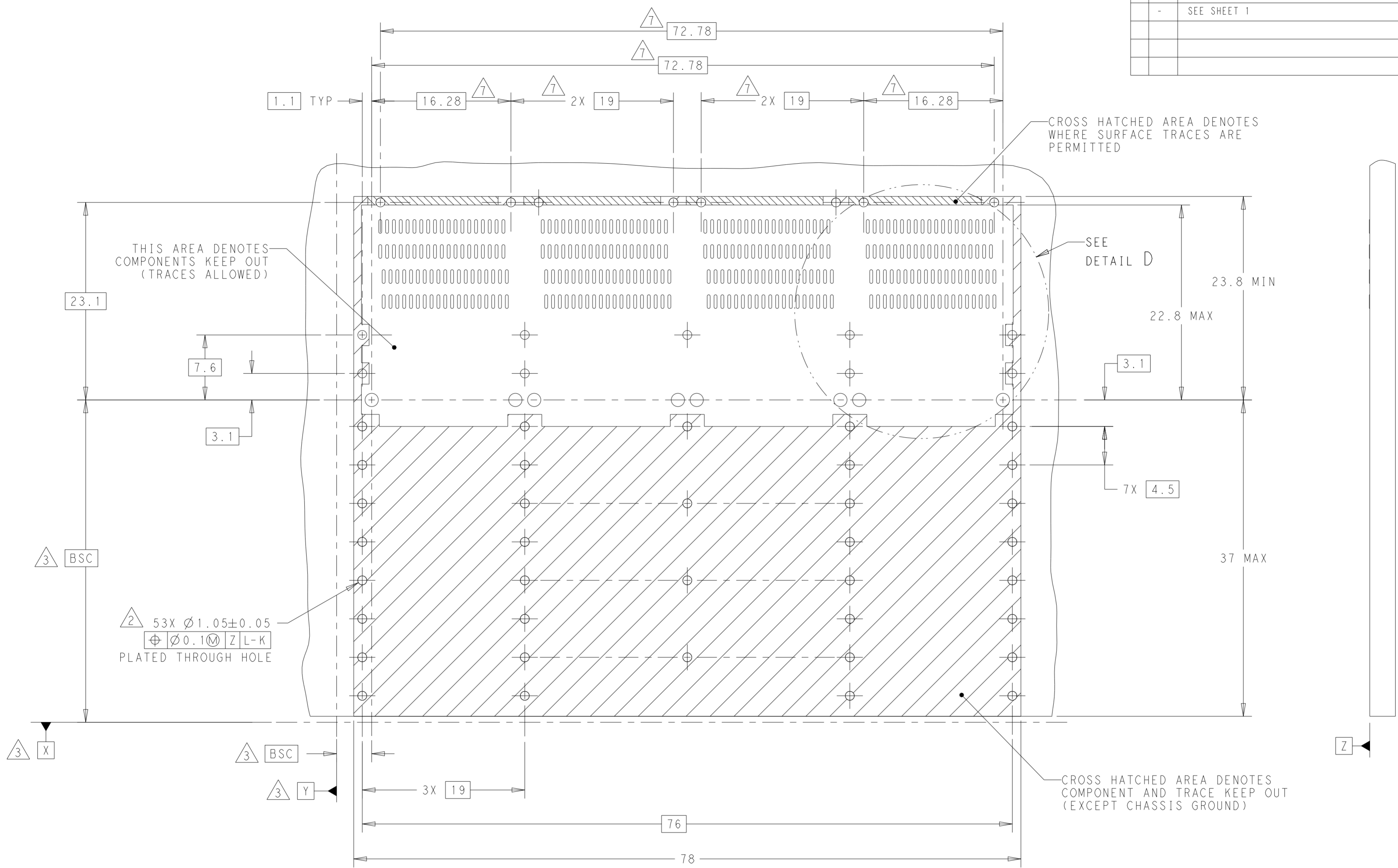

RECOMMENDED PCB LAYOUT  
 BELLY TO BELLY  
 SCALE 3:1

THIS DRAWING IS A CONTROLLED DOCUMENT.		DWN J. WANG	10OCT2018	 TE Connectivity	NAME CAGE WITH HEATSINK THRU BEZEL, 1X4, QSFP DD
DIMENSIONS: mm		CHK S. HAN	10OCT2018		
		APVD S. HAN	10OCT2018		
TOLERANCES UNLESS OTHERWISE SPECIFIED:		PRODUCT SPEC	-		
0 PLC ±0.25 1 PLC ±0.25 2 PLC ±0.25 3 PLC ± 4 PLC ± ANGLES ± FINISH ±		APPLICATION SPEC	-	SIZE A2	CAGE CODE -
MATERIAL -		WEIGHT -	CUSTOMER DRAWING	DRAWING NO C-2343989	RESTRICTED TO -
			SCALE 2:1	SHEET 6 OF 7	REV A1