

THIS DRAWING IS UNPUBLISHED. RELEASED FOR PUBLICATION 20  
 © COPYRIGHT 20 BY - ALL RIGHTS RESERVED.

REVISIONS				
P	LTR	DESCRIPTION	DATE	APVD
A		PRODUCTION RELEASE	13JUN2019	JW SH
A1		REVISED PER ECN-21-123572	14OCT2021	SH SZ

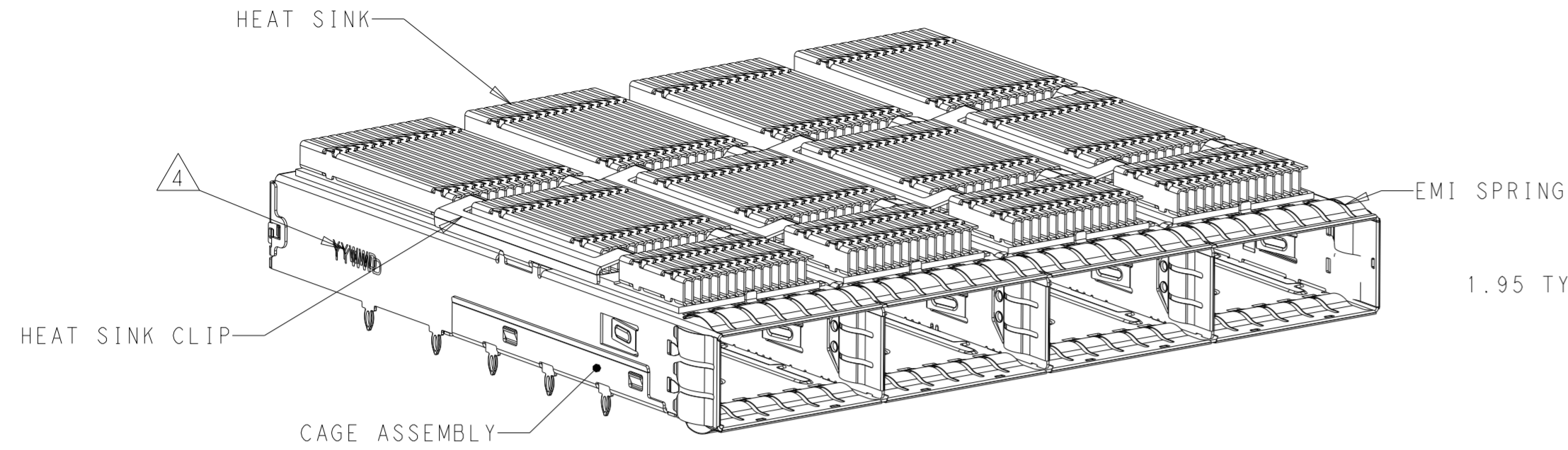

2343989-1 AS SHOWN

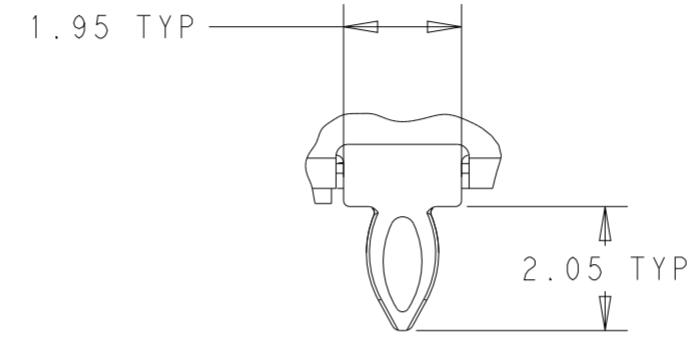

DETAIL A  
SCALE 8:1

- 1 CAGE ASSEMBLY: STAINLESS STEEL.  
HEAT SINK: ALUMINUM/NICKEL PLATE.  
HEAT SINK CLIP: STAINLESS STEEL.  
EMI SPRING: COPPER ALLOY/NICKEL PLATE.
- 2 REFERENCE APPLICATION SPECIFICATION 114-32023 FOR RECOMMENDED DRILL HOLE DIAMETER AND PLATING THICKNESS. BOARD LAYOUT PER THIS PRINT.
- 3 DATUM AND BASIC DIMENSION ESTABLISHED BY CUSTOMER.
- 4 DATE CODE (YYWW) MARKED APPROXIMATELY AS SHOWN.
- 5. MATES WITH QSFP DD MSA COMPATIBLE TRANSCEIVER.
- 6. MINIMUM PC BOARD THICKNESS: SINGLE SIDED: 1.45 MIN  
DOUBLE SIDED: 2.20 MIN
- 7 ONLY FOR VERSION WITH REAR EONS

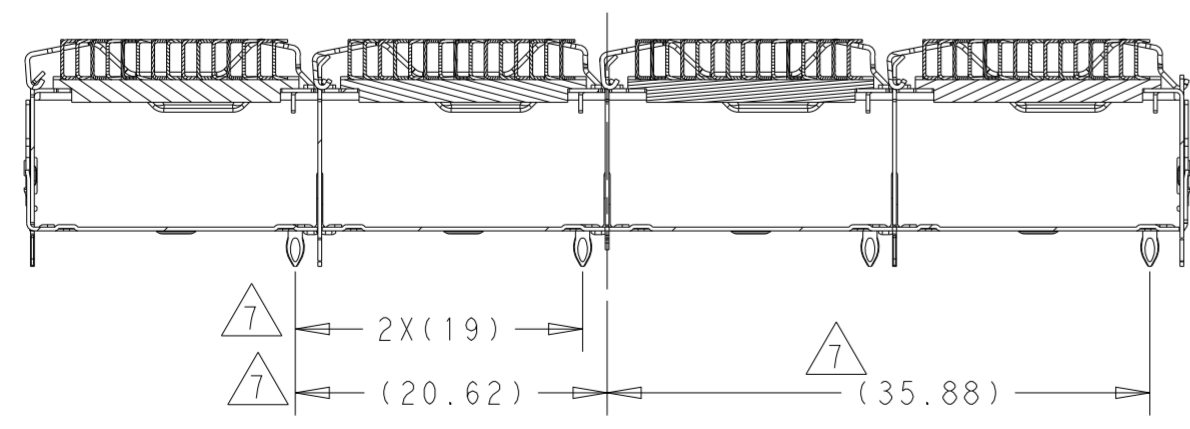
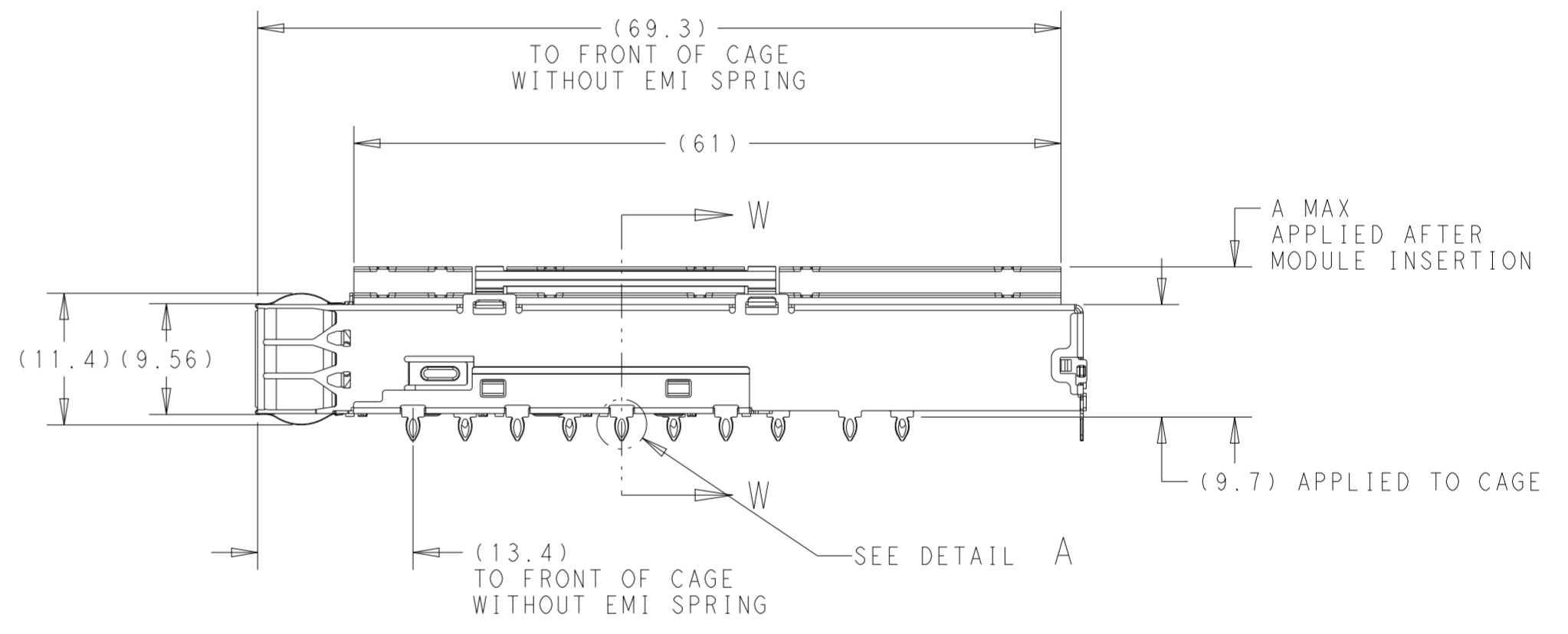
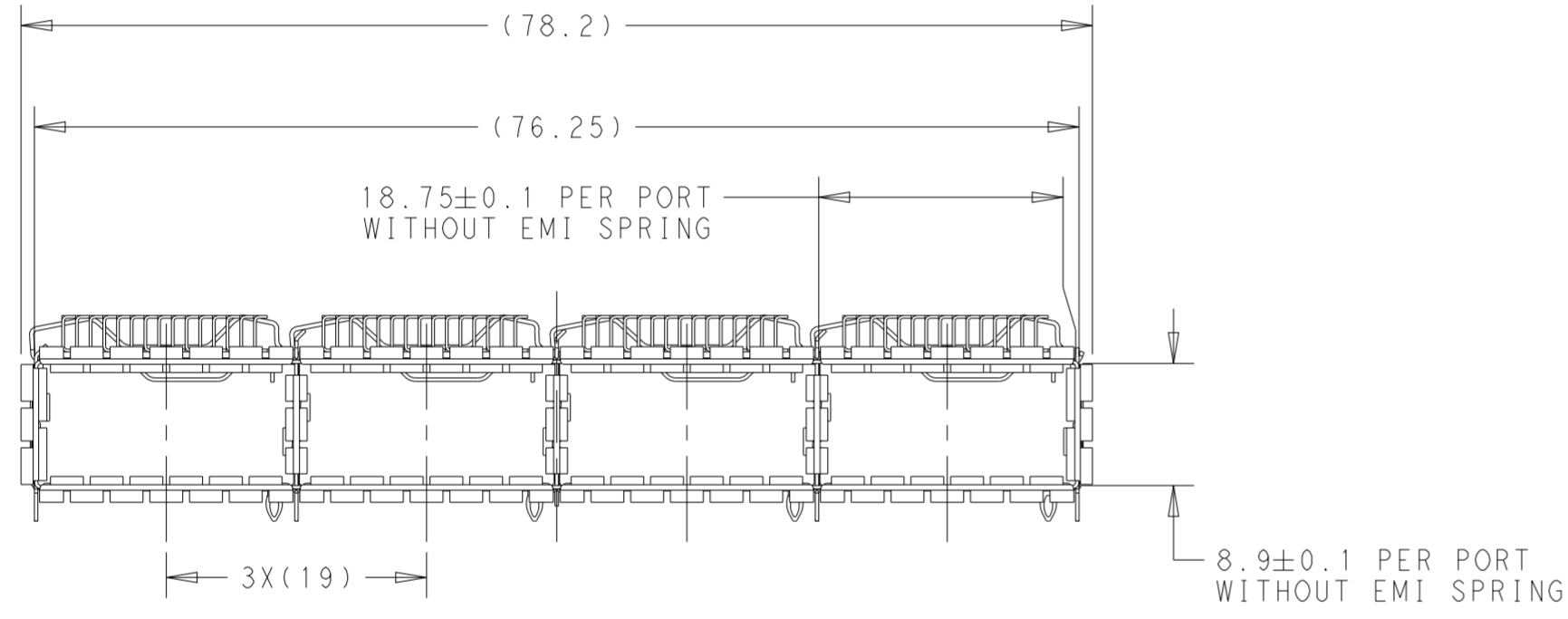

For 2343989-1/-2-3 WITH REAR EONS  
SECTION W-W

VERSION	DIM A	PART NUMBER
W REAR EONS	15.5	2343989-7
W/O REAR EONS	23	1-2343989-3
W/O REAR EONS	16	1-2343989-2
W/O REAR EONS	13.7	1-2343989-1
W REAR EONS	19.75	2343989-6
W REAR EONS	15.55	2343989-5
W REAR EONS	23	2343989-3
W REAR EONS	16	2343989-2
W REAR EONS	13.7	2343989-1

THIS DRAWING IS A CONTROLLED DOCUMENT.		DWN J. WANG 10OCT2018	TE Connectivity	
DIMENSIONS: mm		CHK S. HAN 10OCT2018		
TOLERANCES UNLESS OTHERWISE SPECIFIED:		APVD S. HAN 10OCT2018	NAME CAGE WITH HEATSINK THRU BEZEL, 1X4, QSFP DD	
0 PLC ±0.25	1 PLC ±0.25	PRODUCT SPEC -	SIZE A2	CAGE CODE -
2 PLC ±0.25	3 PLC ±	APPLICATION SPEC -	DRAWING NO C-2343989	RESTRICTED TO -
4 PLC ±	ANGLES ±	WEIGHT -	SCALE 2:1	SHEET 1 OF 7
FINISH -1	FINISH -1	CUSTOMER DRAWING	REV A1	

REVISIONS				
P	LTR	DESCRIPTION	DATE	APVD
-		SEE SHEET 1	-	-

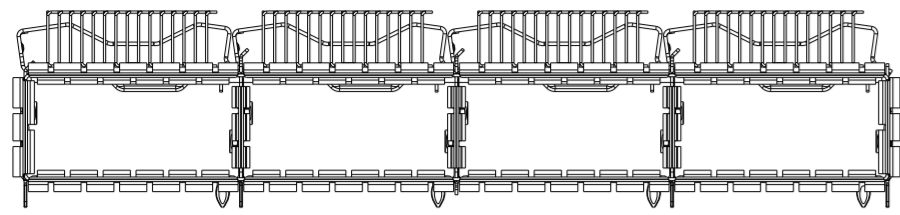

2343989-2  
 UNMARKED DIMENSIONS SAME AS 2343989-1  
 SCALE 3:2

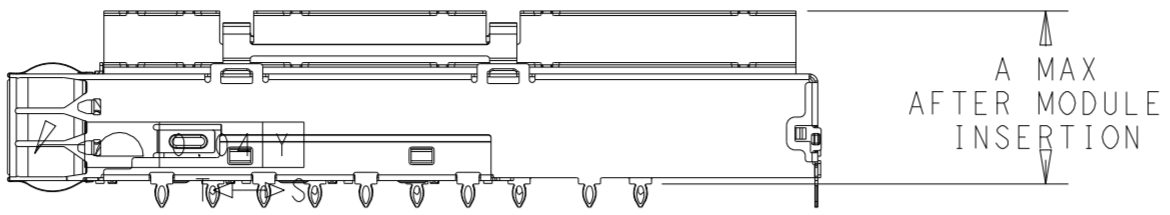

A MAX  
 AFTER MODULE  
 INSERTION

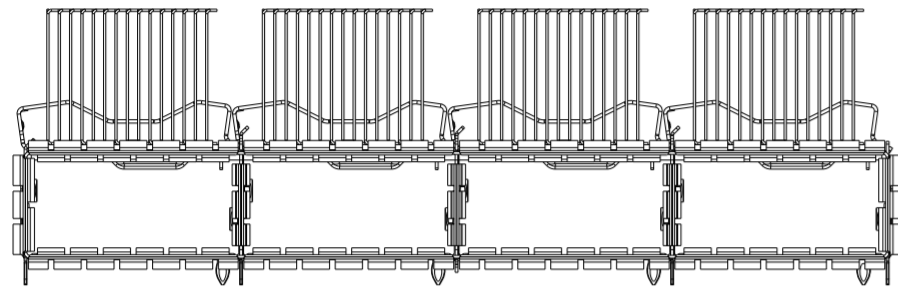
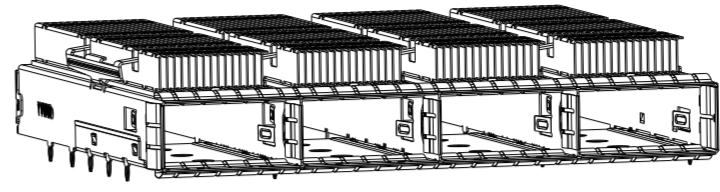

2343989-3  
 UNMARKED DIMENSIONS SAME AS 2343989-1  
 SCALE 3:2

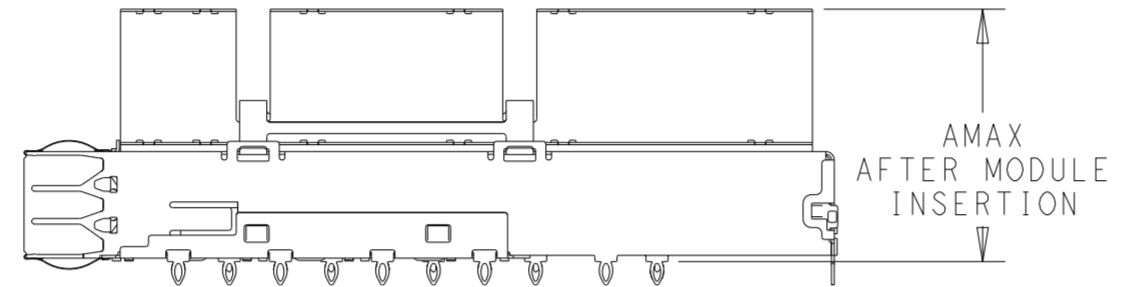

A MAX  
 AFTER MODULE  
 INSERTION

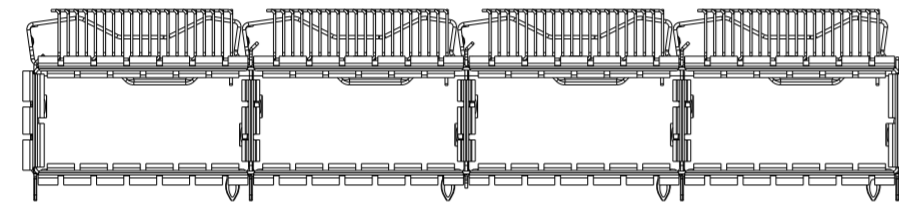
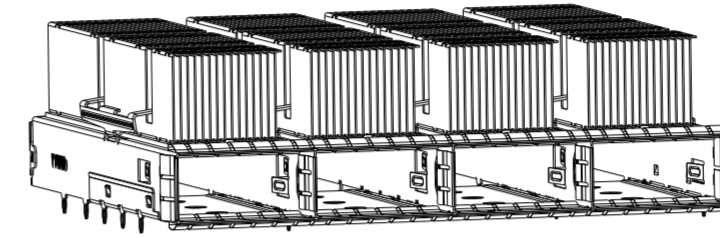

2343989-5  
 UNMARKED DIMENSIONS SAME AS 2343989-3  
 SCALE 3:2

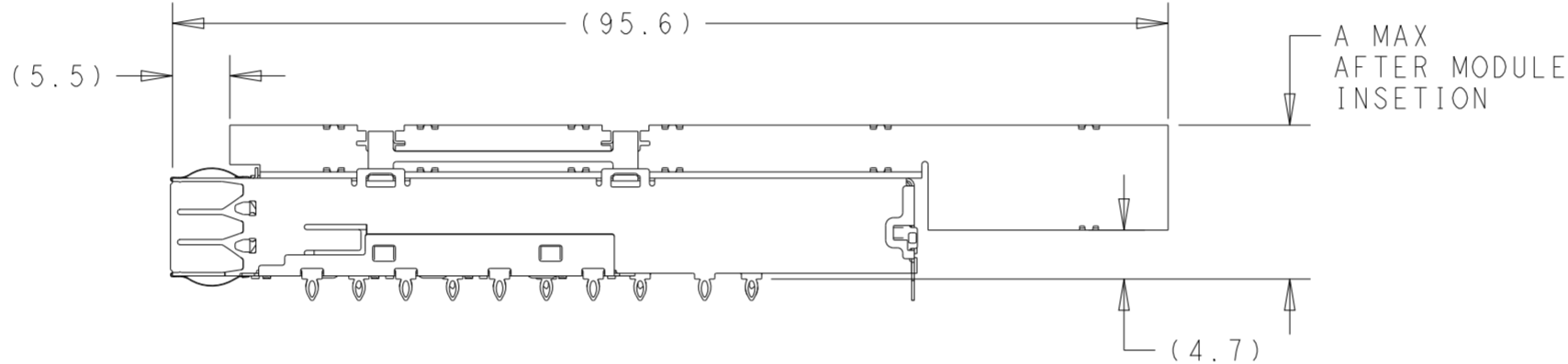

A MAX  
 AFTER MODULE  
 INSERTION

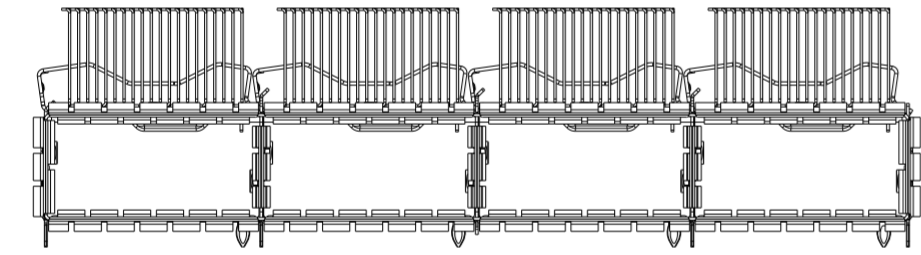
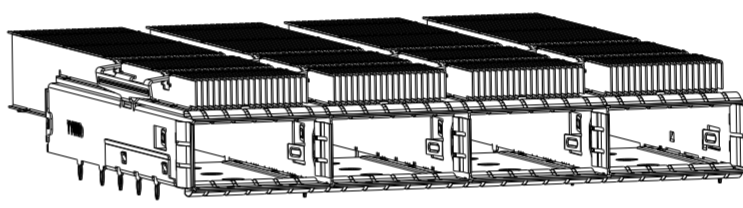

2343989-6  
 UNMARKED DIMENSIONS SAME AS 2343989-3  
 SCALE 3:2

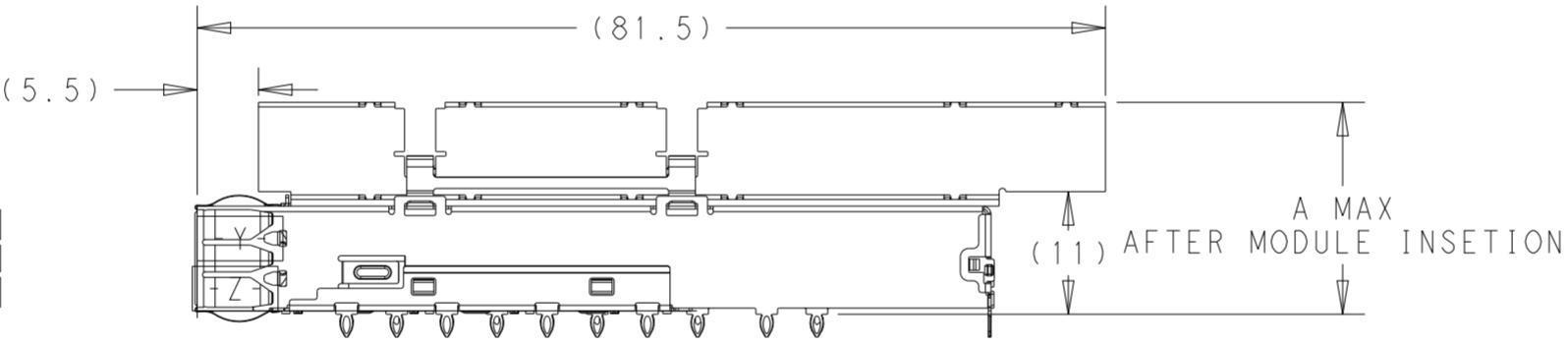

A MAX  
 AFTER MODULE  
 INSERTION

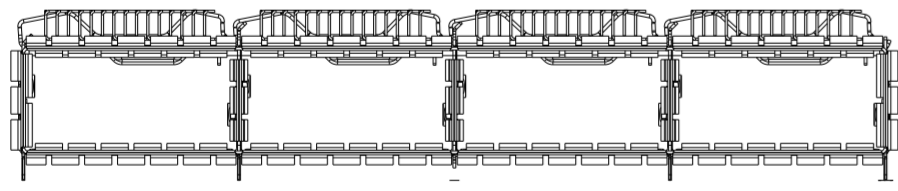
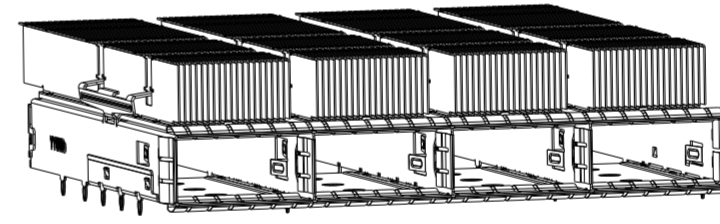

1-2343989-1  
 WITHOUT REAR EONS  
 UNMARKED DIMENSIONS SAME AS 2343989-1  
 SCALE 3:2

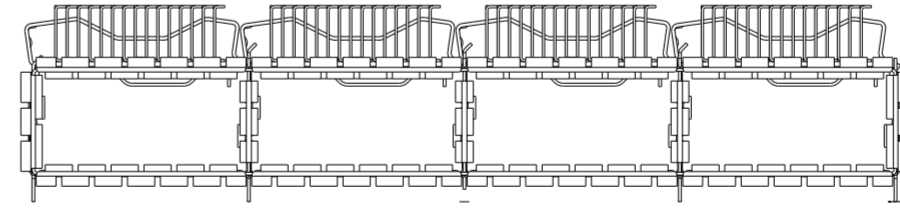
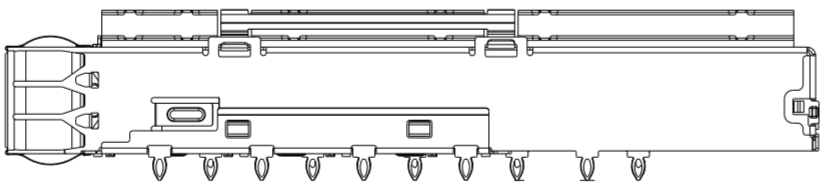

1-2343989-2  
 WITHOUT REAR EONS  
 UNMARKED DIMENSIONS SAME AS 2343989-2  
 SCALE 3:2

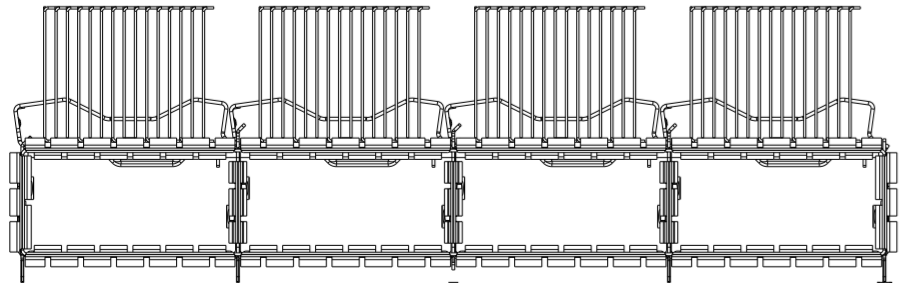
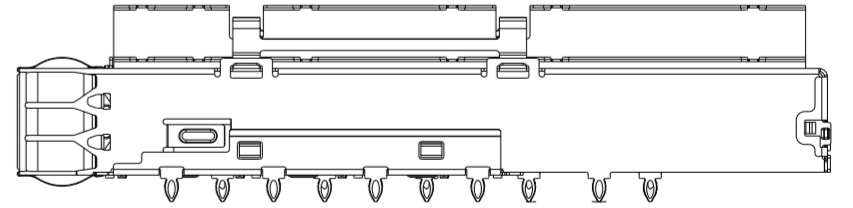

1-2343989-3  
 WITHOUT REAR EONS  
 UNMARKED DIMENSIONS SAME AS 2343989-3  
 SCALE 3:2

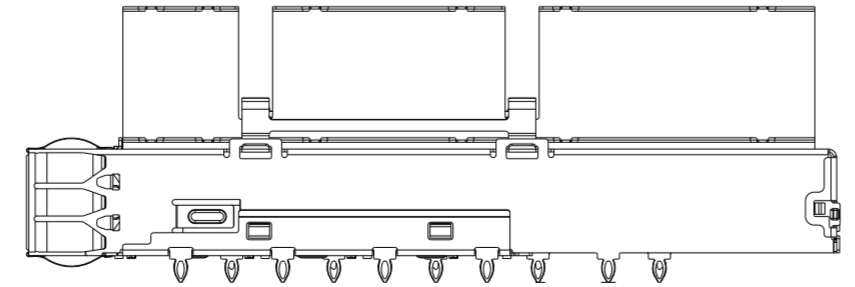

THIS DRAWING IS A CONTROLLED DOCUMENT.		DWN J. WANG 10OCT2018	 TE Connectivity	NAME CAGE WITH HEATSINK THRU BEZEL, 1X4, QSFP DD		
DIMENSIONS: mm		CHK S. HAN 10OCT2018		SIZE A2	CAGE CODE -	DRAWING NO C-2343989
TOLERANCES UNLESS OTHERWISE SPECIFIED: 0 PLC ±0.25 1 PLC ±0.25 2 PLC ±0.25 3 PLC ± 4 PLC ± ANGLES ± FINISH		APVD S. HAN 10OCT2018		RESTRICTED TO -	SCALE 2:1	SHEET 2 OF 7
MATERIAL -		PRODUCT SPEC -		WEIGHT -	CUSTOMER DRAWING	REV A1

THIS DRAWING IS UNPUBLISHED. RELEASED FOR PUBLICATION 20  
 © COPYRIGHT 20 BY - ALL RIGHTS RESERVED.

REVISIONS				
P	LTR	DESCRIPTION	DATE	APVD
-		SEE SHEET 1	-	-

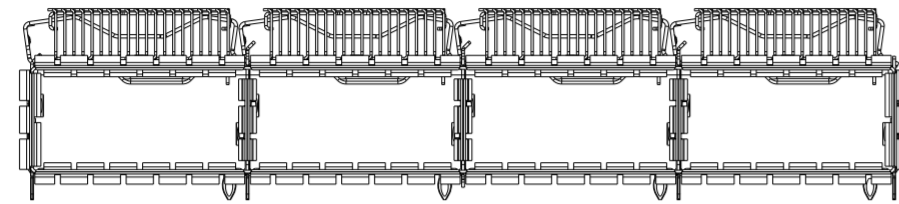

2343989-7 AS SHOWN  
 SAME AS -1 EXCEPT HEAT SINK  
 SCALE 3:2

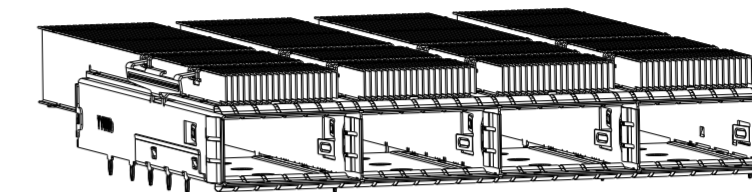
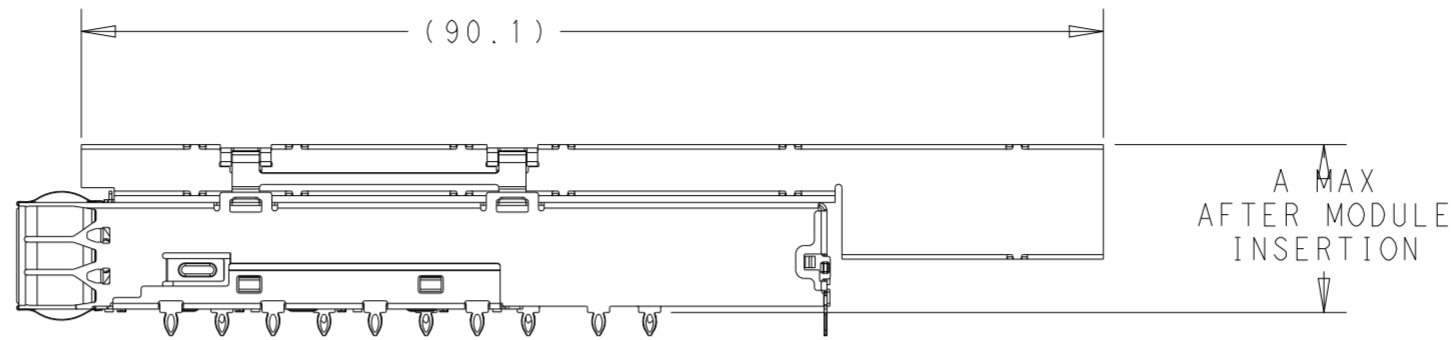

THIS DRAWING IS A CONTROLLED DOCUMENT.		DWN J. WANG 10OCT2018	 TE Connectivity	
DIMENSIONS: mm		CHK S. HAN 10OCT2018		
TOLERANCES UNLESS OTHERWISE SPECIFIED:		APVD S. HAN 10OCT2018	NAME CAGE WITH HEATSINK THRU BEZEL, 1X4, QSFP DD	
0 PLC ±0.25 1 PLC ±0.25 2 PLC ±0.25 3 PLC ± 4 PLC ± ANGLES ± FINISH ±		PRODUCT SPEC -	RESTRICTED TO -	
MATERIAL -		APPLICATION SPEC -	SIZE A2	CAGE CODE -
		WEIGHT -	DRAWING NO C-2343989	
		CUSTOMER DRAWING	SCALE 2:1	SHEET 3 OF 7
			REV A1	

THIS DRAWING IS UNPUBLISHED. RELEASED FOR PUBLICATION 20  
 © COPYRIGHT 20 BY - ALL RIGHTS RESERVED.

REVISIONS				
P	LTR	DESCRIPTION	DATE	APVD
-	-	SEE SHEET 1	-	-

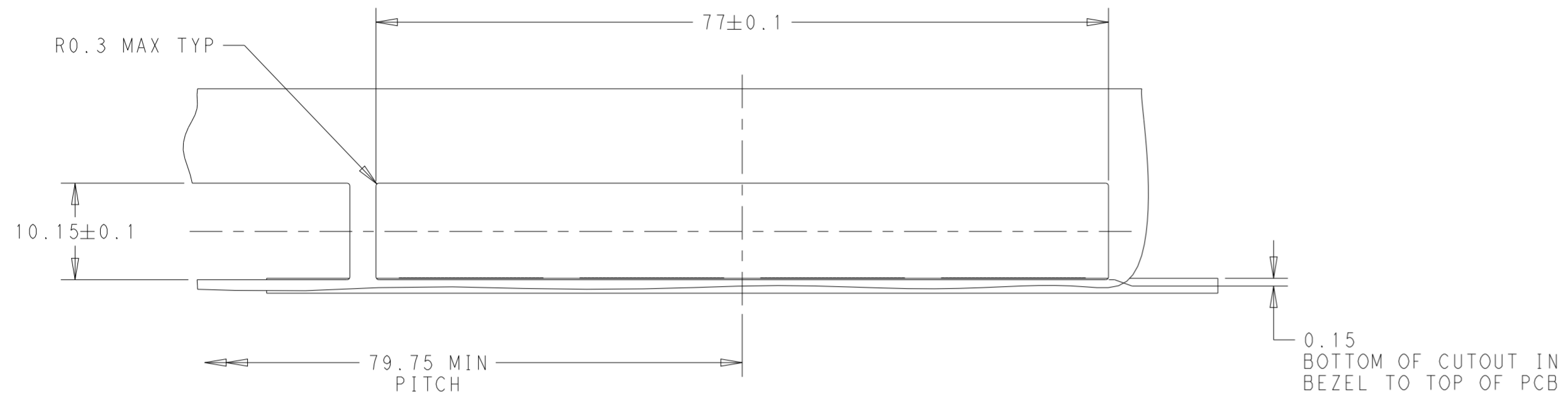

CAGE ASSEMBLY OMITTED FOR CLARITY

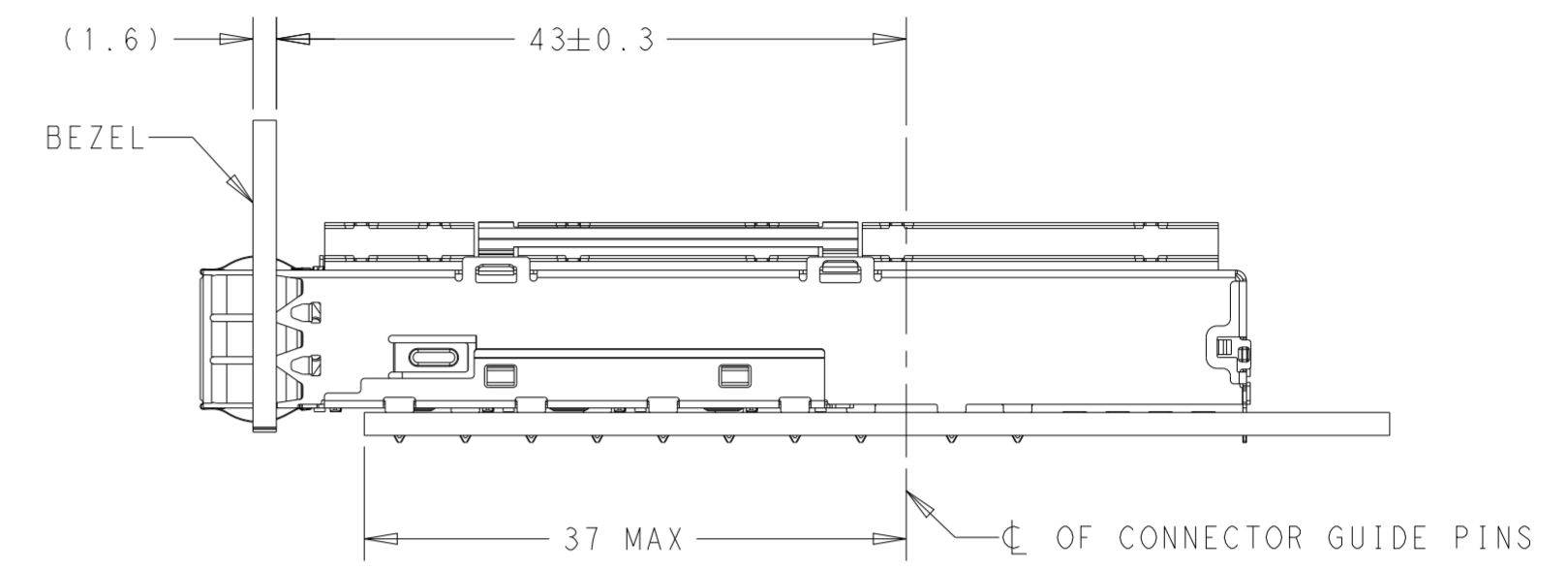

SINGLE SIDE MOUNTING

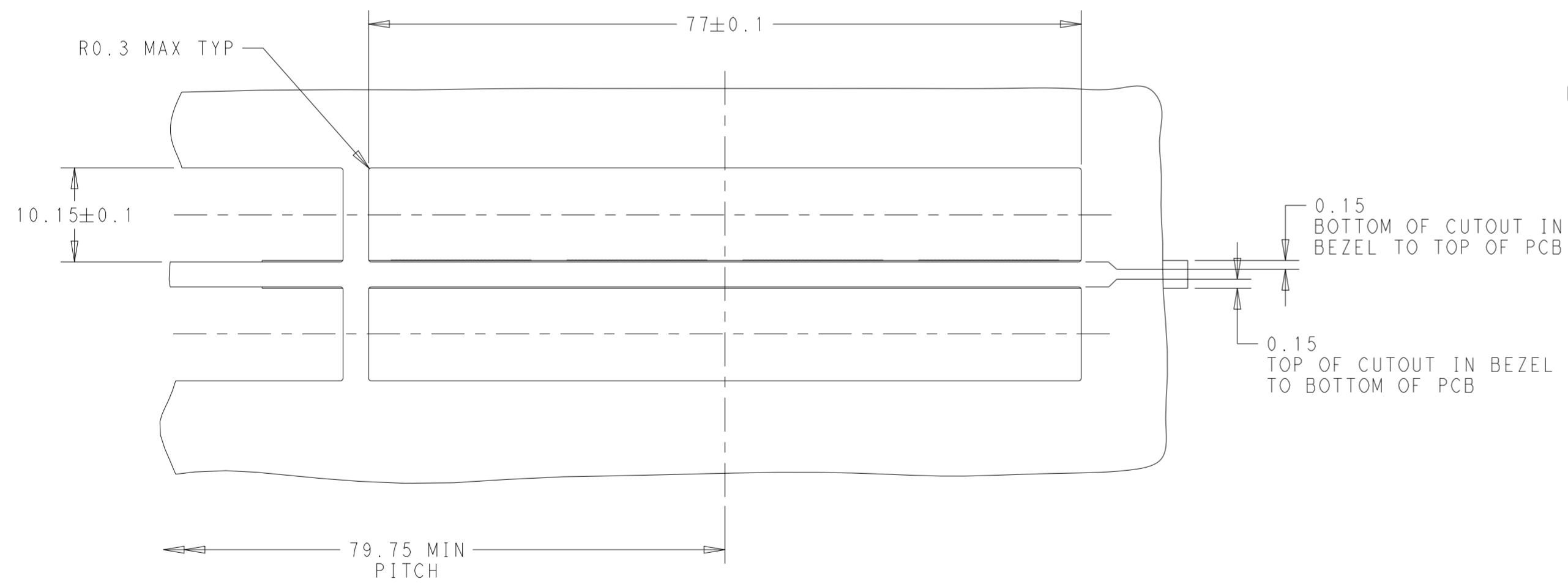

CAGE ASSEMBLY OMITTED FOR CLARITY

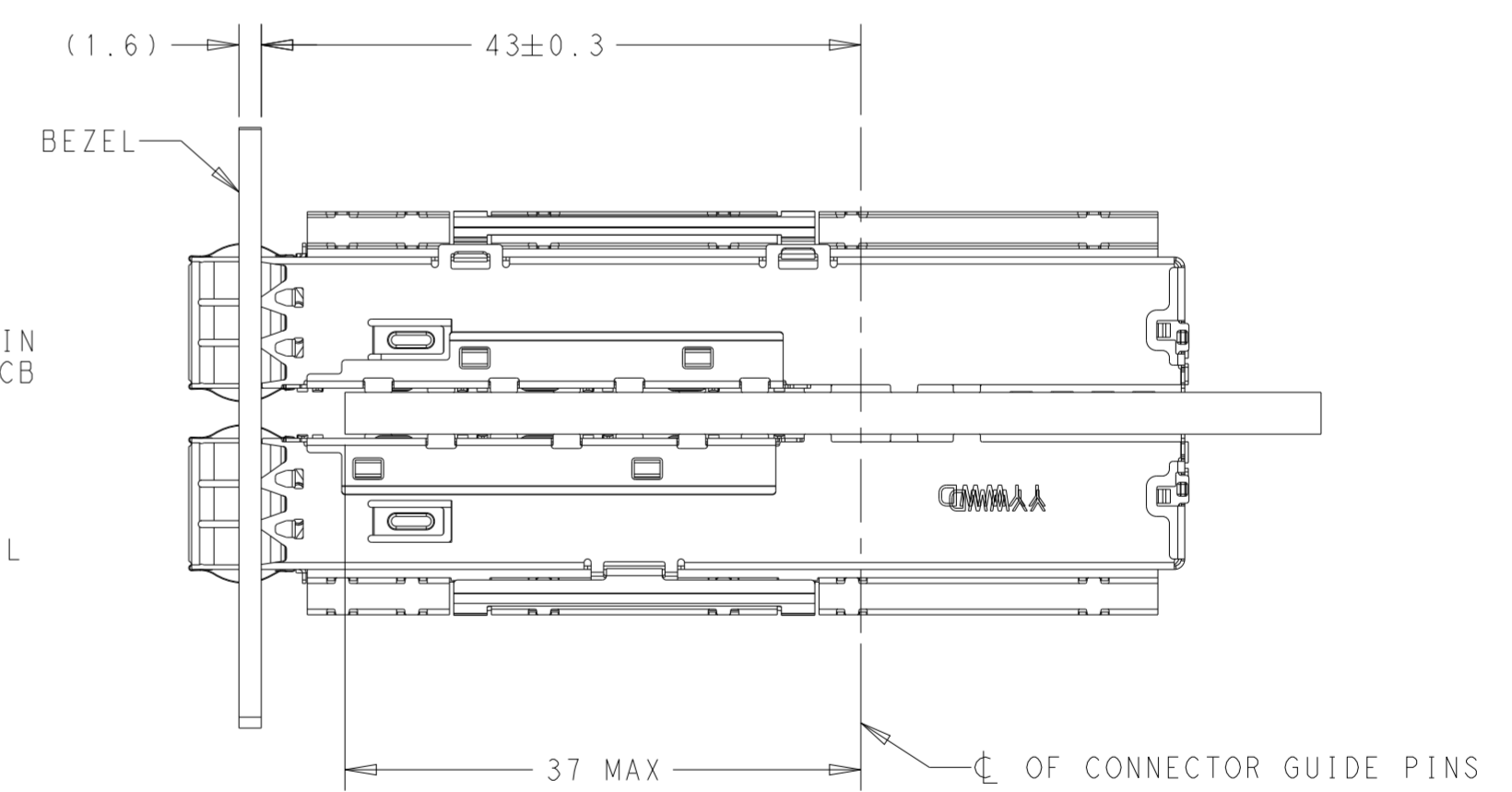

BELLY TO BELLY MOUNTING

THIS DRAWING IS A CONTROLLED DOCUMENT.		DWN J. WANG 10OCT2018	TE Connectivity	
DIMENSIONS: mm		CHK S. HAN 10OCT2018		
TOLERANCES UNLESS OTHERWISE SPECIFIED:		APVD S. HAN 10OCT2018	NAME CAGE WITH HEATSINK THRU BEZEL, 1X4, QSFP DD	
0 PLC	±0.25	PRODUCT SPEC	SIZE	CAGE CODE
1 PLC	±0.25	APPLICATION SPEC	A2	-
2 PLC	±0.25	WEIGHT	SCALE	DRAWING NO
3 PLC	±	CUSTOMER DRAWING	2:1	C-2343989
4 PLC	±	RESTRICTED TO	SHEET	4 OF 7
ANGLES	±	REV	REV	A1
FINISH	-			

REVISIONS				
P	LTR	DESCRIPTION	DATE	APVD
-	-	SEE SHEET 1	-	-

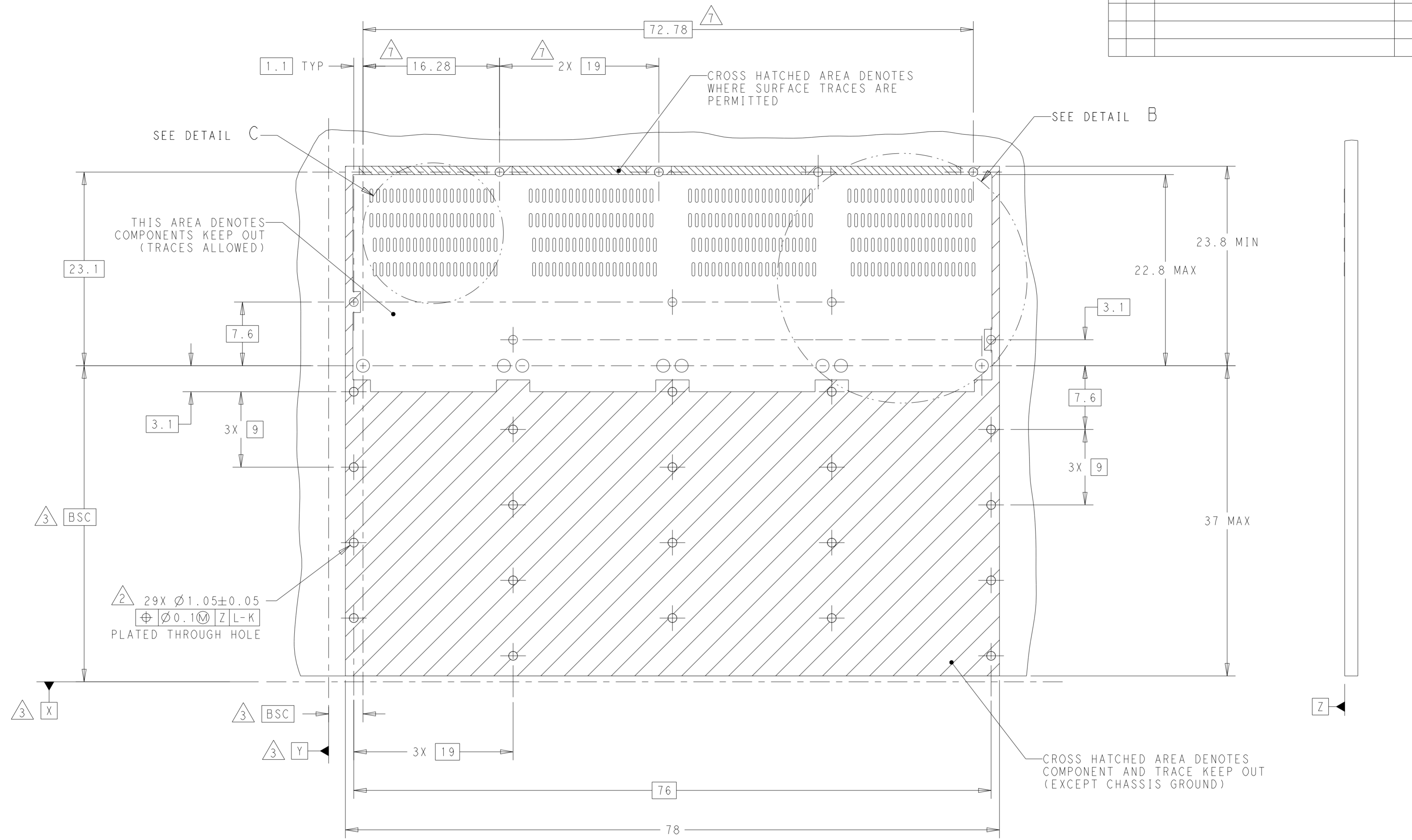

RECOMMENDED PCB LAYOUT  
 SINGLE TYPE  
 SCALE 3:1

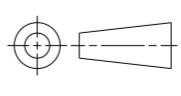
THIS DRAWING IS A CONTROLLED DOCUMENT.		DWN J. WANG	10OCT2018	 TE Connectivity
DIMENSIONS: mm		CHK S. HAN	10OCT2018	
		APVD S. HAN	10OCT2018	
TOLERANCES UNLESS OTHERWISE SPECIFIED:		PRODUCT SPEC		NAME CAGE WITH HEATSINK THRU BEZEL, 1X4, QSFP DD
0 PLC	±0.25	APPLICATION SPEC		SIZE A2
1 PLC	±0.25	WEIGHT		CAGE CODE -
2 PLC	±0.25	CUSTOMER DRAWING		DRAWING NO C-2343989
3 PLC	±	SCALE		2:1
4 PLC	±	SHEET		5 OF 7
ANGLES	±	REV		A1
FINISH	±	RESTRICTED TO		

REVISIONS				
P	LTR	DESCRIPTION	DATE	APVD
-	-	SEE SHEET 1	-	-

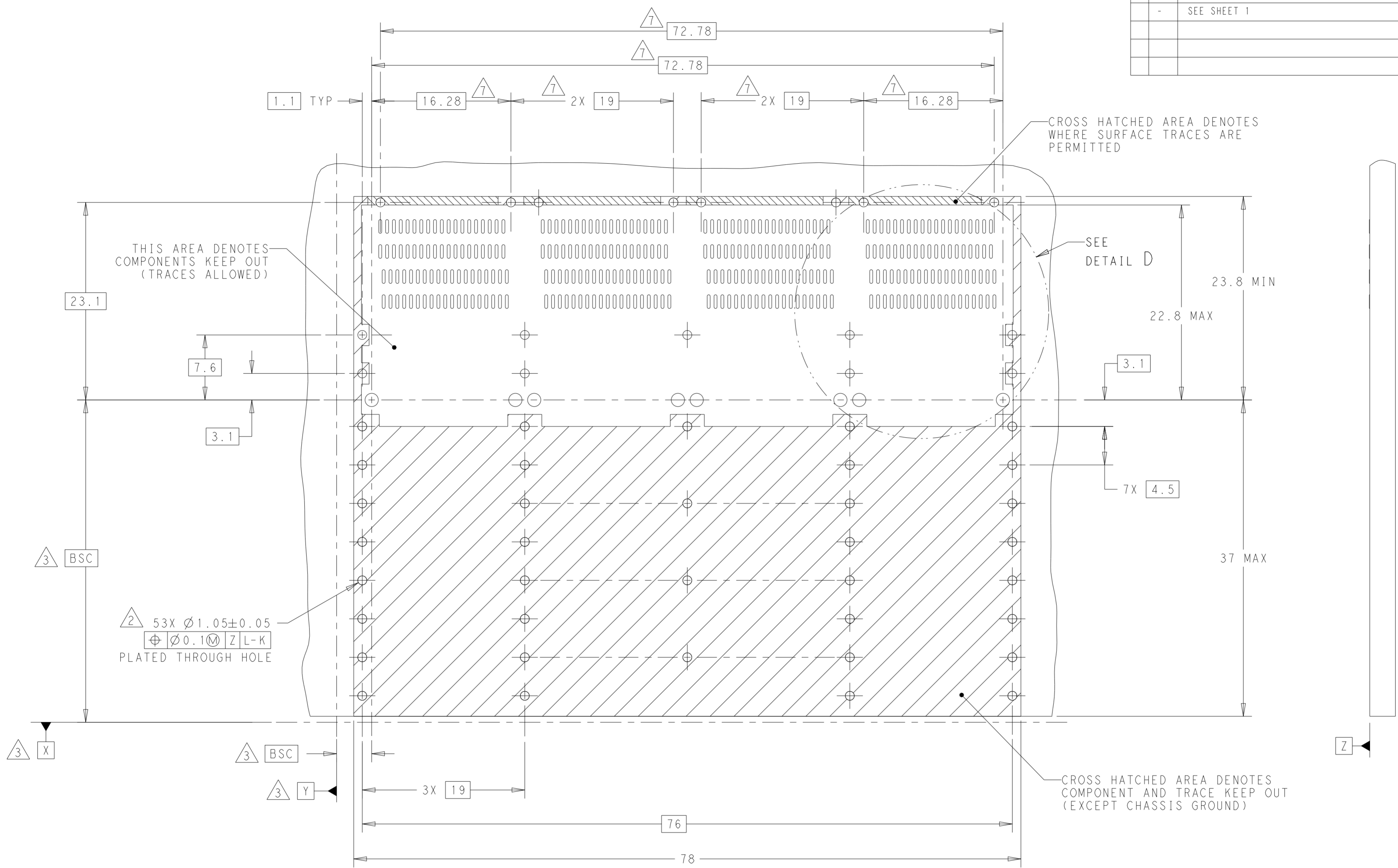

RECOMMENDED PCB LAYOUT  
 BELLY TO BELLY  
 SCALE 3:1

THIS DRAWING IS A CONTROLLED DOCUMENT.		DWN J. WANG 10OCT2018	 TE Connectivity
DIMENSIONS: mm		CHK S. HAN 10OCT2018	
TOLERANCES UNLESS OTHERWISE SPECIFIED:		APVD S. HAN 10OCT2018	NAME CAGE WITH HEATSINK THRU BEZEL, 1X4, QSFP DD
0 PLC ±0.25	1 PLC ±0.25	PRODUCT SPEC	SIZE A2
2 PLC ±0.25	3 PLC ±	APPLICATION SPEC	CAGE CODE -
4 PLC ±	ANGLES ±	WEIGHT	DRAWING NO C-2343989
MATERIAL	FINISH	CUSTOMER DRAWING	RESTRICTED TO -
		SCALE 2:1	SHEET 6 OF 7
		REV A1	