

P	LTR	DESCRIPTION	DATE	DWN	APVD
1		INITIAL ISSUE	19AUG2020	SM	MZ
2		DRAFTING UPDATES	03SEP2020	SM	MZ
A		PRODUCT UNDER TESTING	24NOV2020	SM	MZ

NOTES:

1. PART NUMBERS: 1-2359422-1 AND 1-2359422-2 ARE CRIMPED CONTACT VERSIONS. CONTACTS SUPPLIED SEPARATELY ON REELS, MUST PURCHASED ACCORDING TO WIRE SIZES. BELOW ARE THE CONTACT PART NUMBERS:

CONTACT P/N	WIRE SIZE
2359527-1	1.5mm ² TO 2.5mm ² 16AWG TO 14AWG
2359527-2	2.5mm ² TO 4.0mm ² 14AWG TO 12AWG

- MATERIALS:
PLASTICS: PBT+PC ALLOY, UL-V0, UV-F1
CONTACTS: COPPER ALLOY, TIN PLATED
SCREWS : STAINLESS STEEL
- OPERATING RATINGS :
VOLTAGE (max): 600Vac Max
CURRENT (max): 25A ON 4.0mm² & 20A ON 12AWG
TEMPERATURE : -40°C TO 85°C
IP RATING : IP67 & IP68
- FOR ASSEMBLY INSTRUCTIONS, REFER APPLICATION SPECIFICATION 114-133123
- PACKAGING: MOQ 200 pcs IN PE BAG

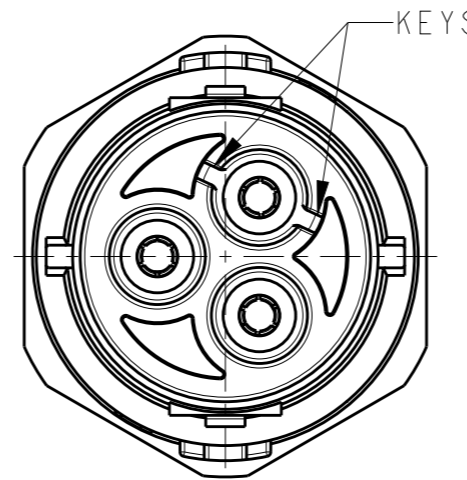
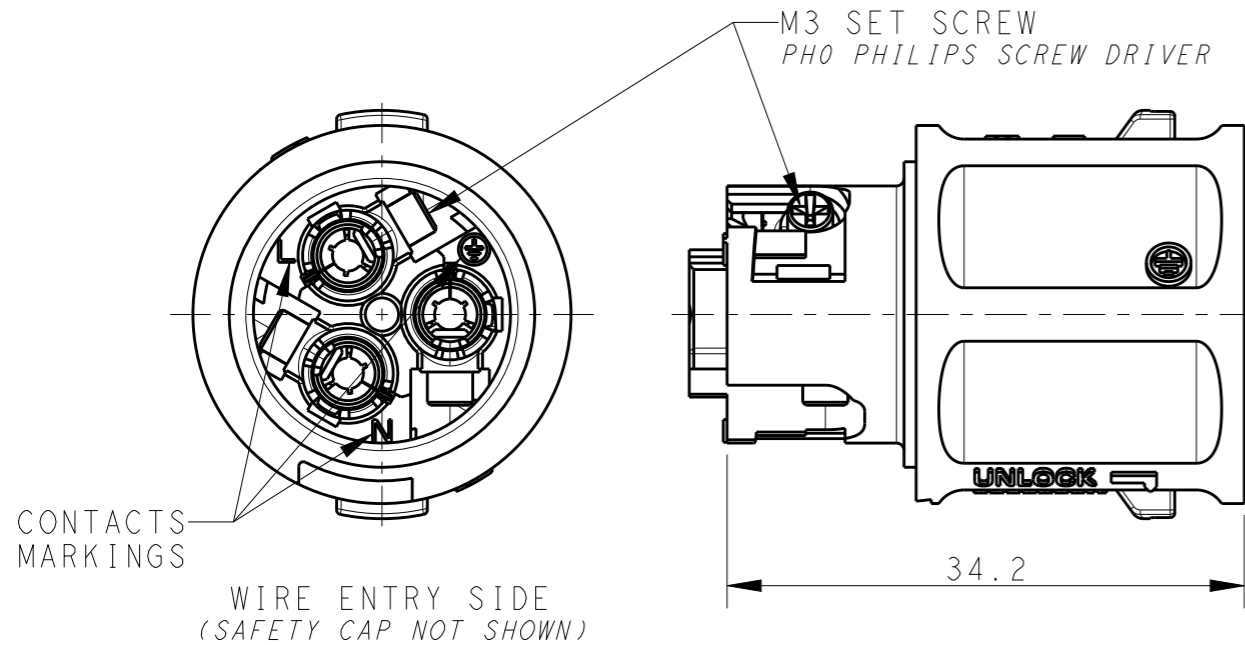
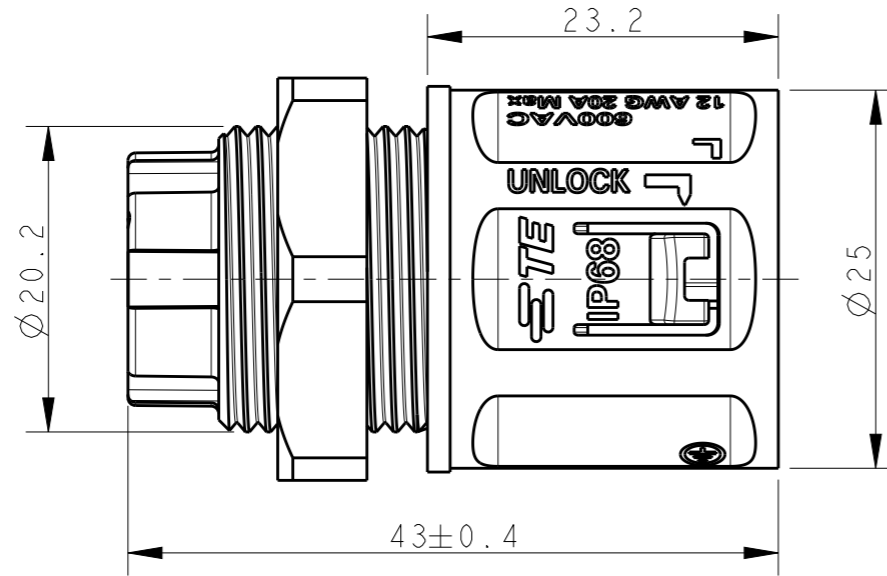

PANEL CUT-OUT RECOMMENDED SIZE

PRODUCT UNDER TESTING
CONTACT PRODUCT ENGINEERING BEFORE USING THIS PRINT

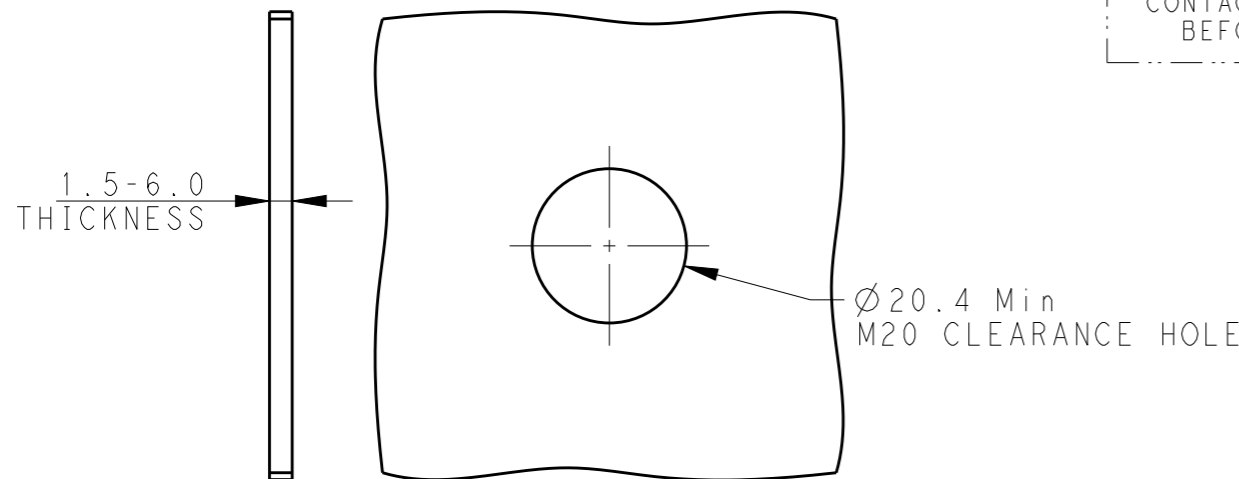

KEY B	CRIMP	PANEL MOUNT SOCKET CONNECTOR	1-2359422-2
KEY A			1-2359422-1
KEY B	SCREW		2359422-2
KEY A			2359422-1
POLARIZING KEY	TERMINATION TYPE	DESCRIPTION	PART NUMBER

THIS DRAWING IS A CONTROLLED DOCUMENT.		DWN	19AUG2020	TE Connectivity NAME NECTOR T, 3Pos, SOCKET CONNECTOR PANEL MOUNT	
DIMENSIONS: mm		CHK	03SEP2020		
TOLERANCES UNLESS OTHERWISE SPECIFIED:		APVD	24NOV2020		
0 PLC ±0.2 1 PLC ±0.2 2 PLC ±0.1 3 PLC ± 4 PLC ± ANGLES ±1°		PRODUCT SPEC	108-133123		
MATERIAL	FINISH	APPLICATION SPEC	114-133123	SIZE	A3
-	-	WEIGHT	-	CAGE CODE	00779
-	-	CUSTOMER DRAWING		DRAWING NO	C-2359422
			SCALE	2:1	SHEET 1 OF 2
					REV A

P	LTR	DESCRIPTION	DATE	DWN	APVD
-		SEE SHEET 1	-	-	-

CRIMP TERMINATION TYPE
 1-2359422-1 & 1-2359422-2
 REFER 114-133123 FOR DETAILED INSTRUCTION

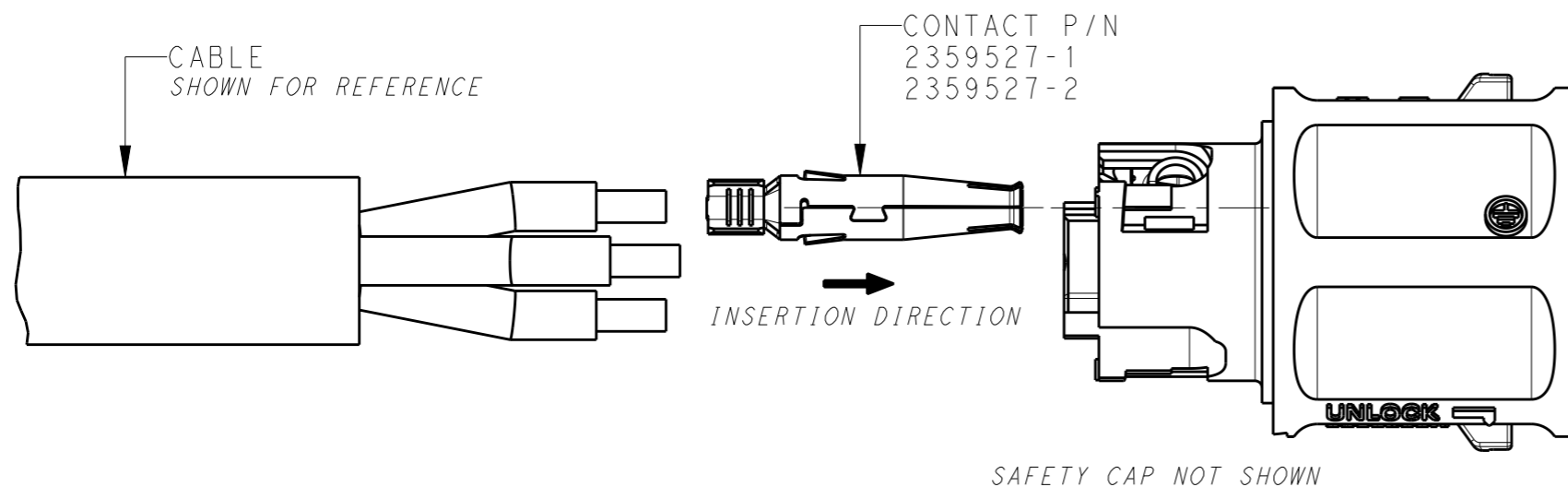

EXPLODED COMPONENTS

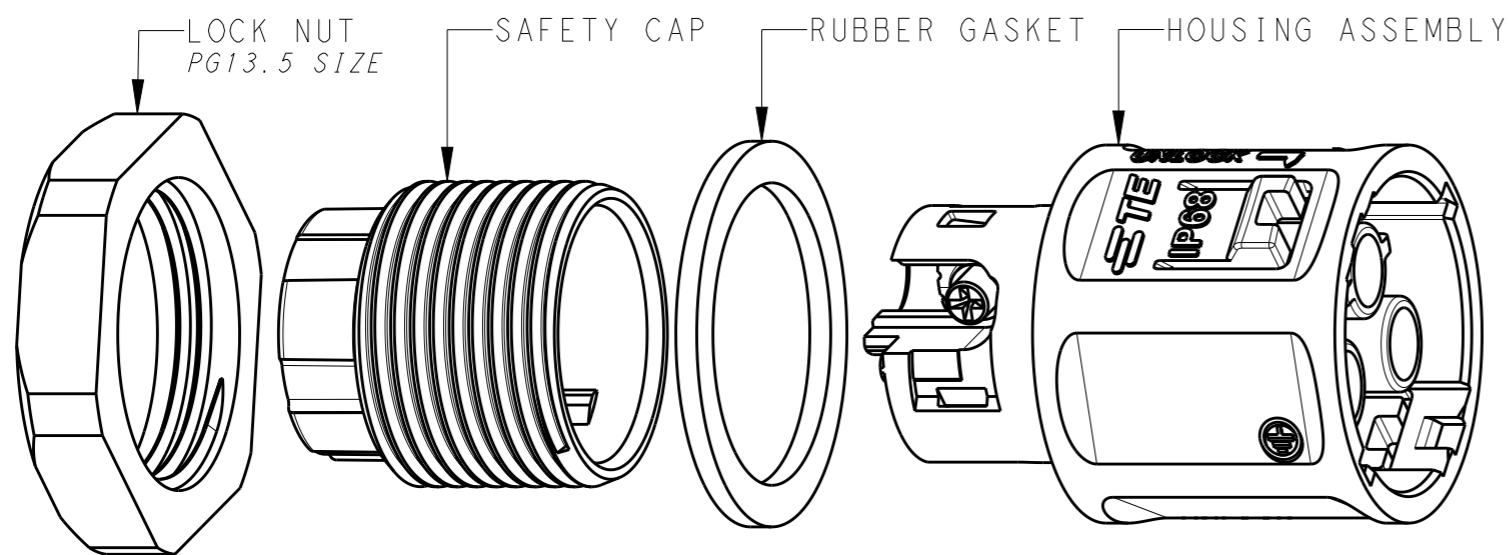

POLARIZING KEY A
 2359422-1
 1-2359422-1

POLARIZING KEY B
 2359422-2
 1-2359422-2

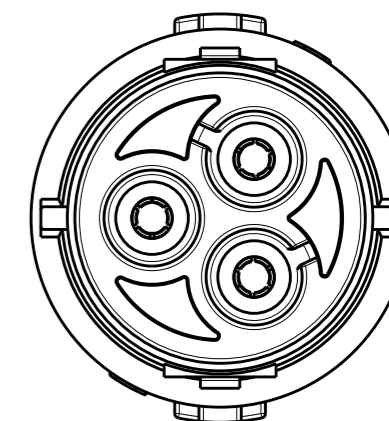
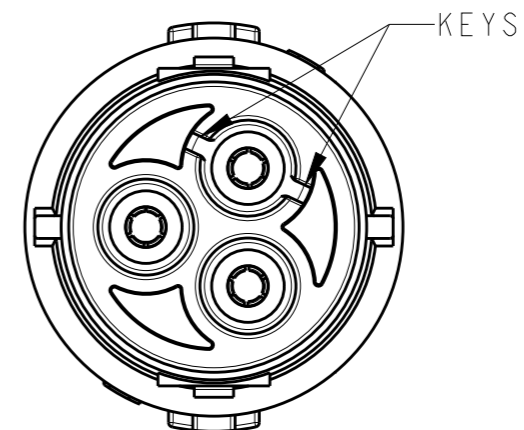

THIS DRAWING IS A CONTROLLED DOCUMENT.

DIMENSIONS: mm	TOLERANCES UNLESS OTHERWISE SPECIFIED:
	0 PLC ±0.2
	1 PLC ±0.2
	2 PLC ±0.1
	3 PLC ±
	4 PLC ±
	ANGLES ±1°
MATERIAL	FINISH
-	-
-	-

DWN	19AUG2020
SUBHASH.M	
CHK	03SEP2020
M. ZUCCA	
APVD	24NOV2020
PETER OTT	
PRODUCT SPEC	108-133123
APPLICATION SPEC	114-133123
WEIGHT	-
CUSTOMER DRAWING	

TE TE Connectivity	
NAME NECTOR T, 3Pos, SOCKET CONNECTOR PANEL MOUNT	
SIZE	RESTRICTED TO
A3	-
CAGE CODE	SCALE
00779	2:1
DRAWING NO	SHEET
C-2359422	2 OF 2
REV	A