

P	LTR	DESCRIPTION	DATE	DWN	APVD
A		RELEASE PER ECN-22-172004	30AUG2022	LL	DZ

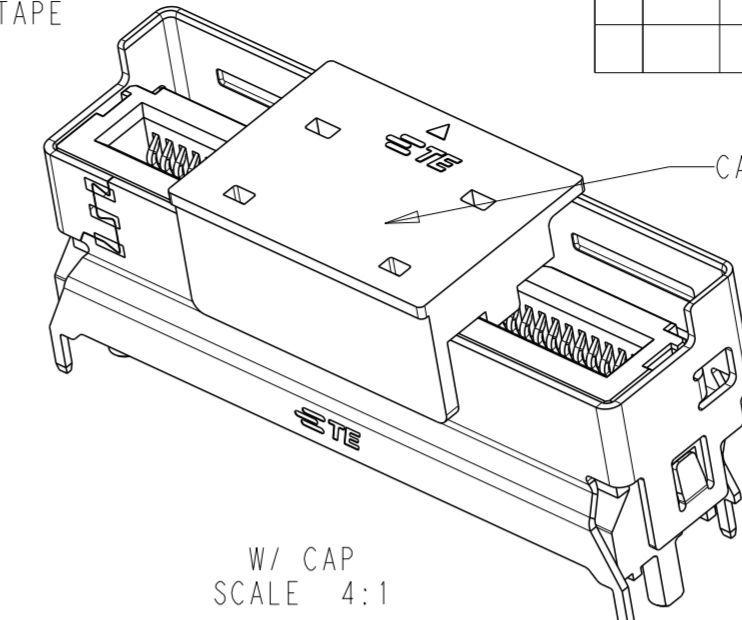

W/ PICK AND PLACE TAPE SCALE 4:1

W/ CAP SCALE 4:1

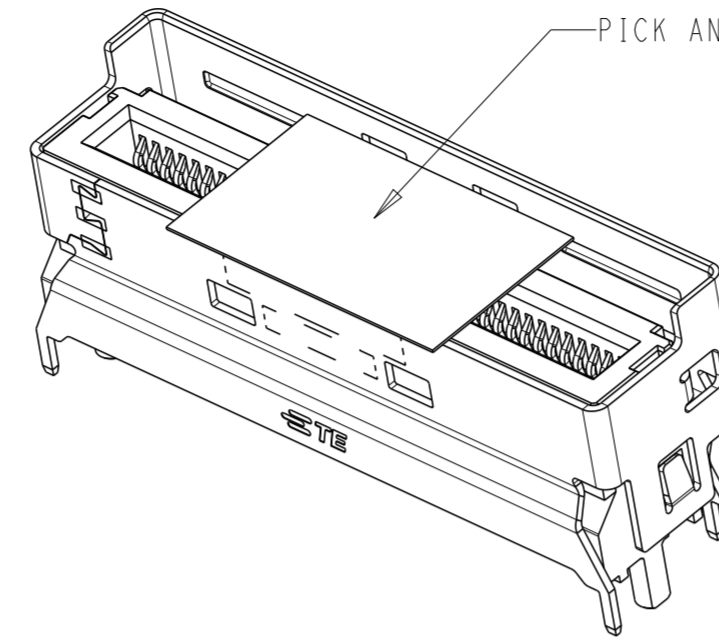
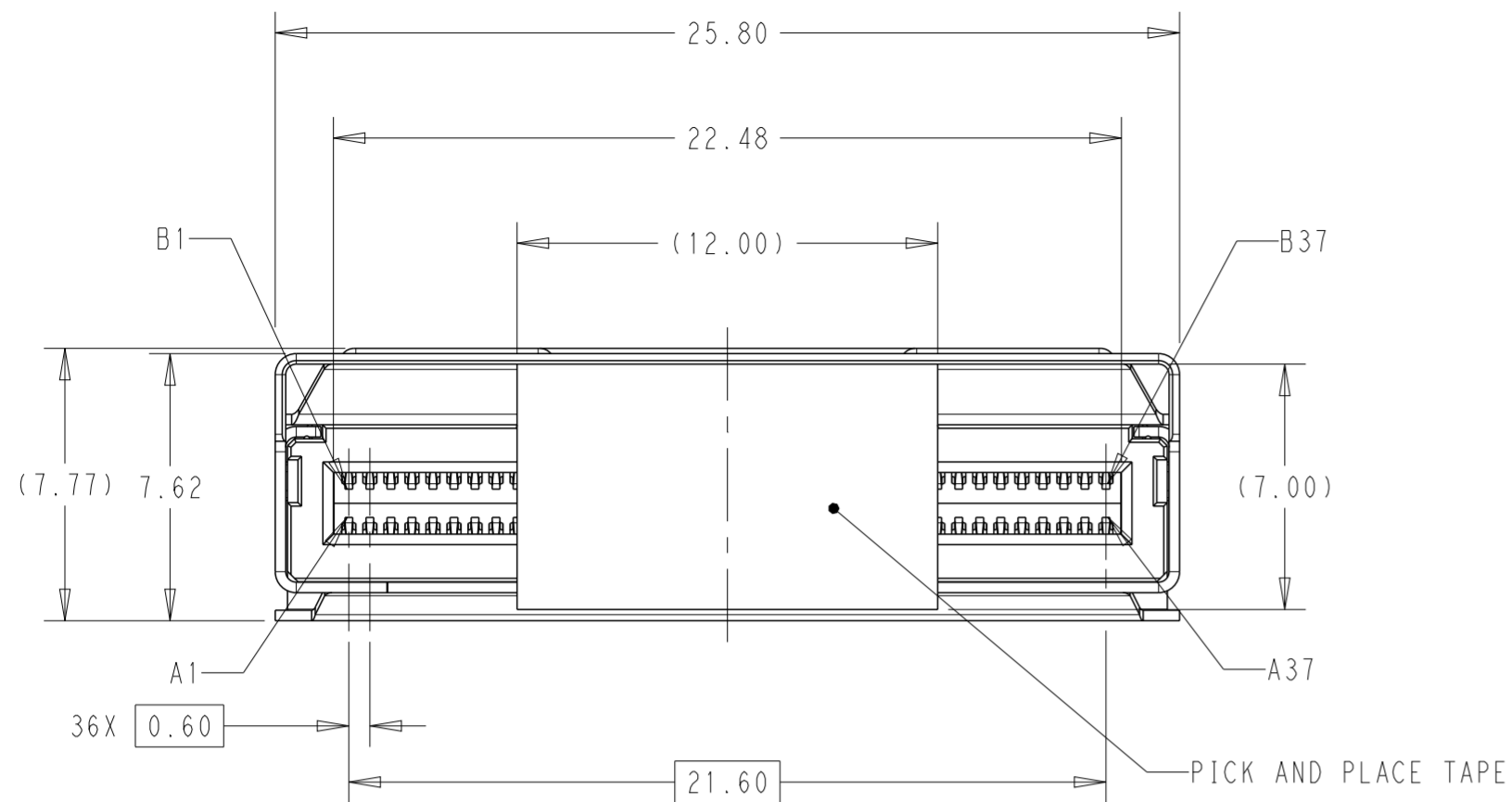
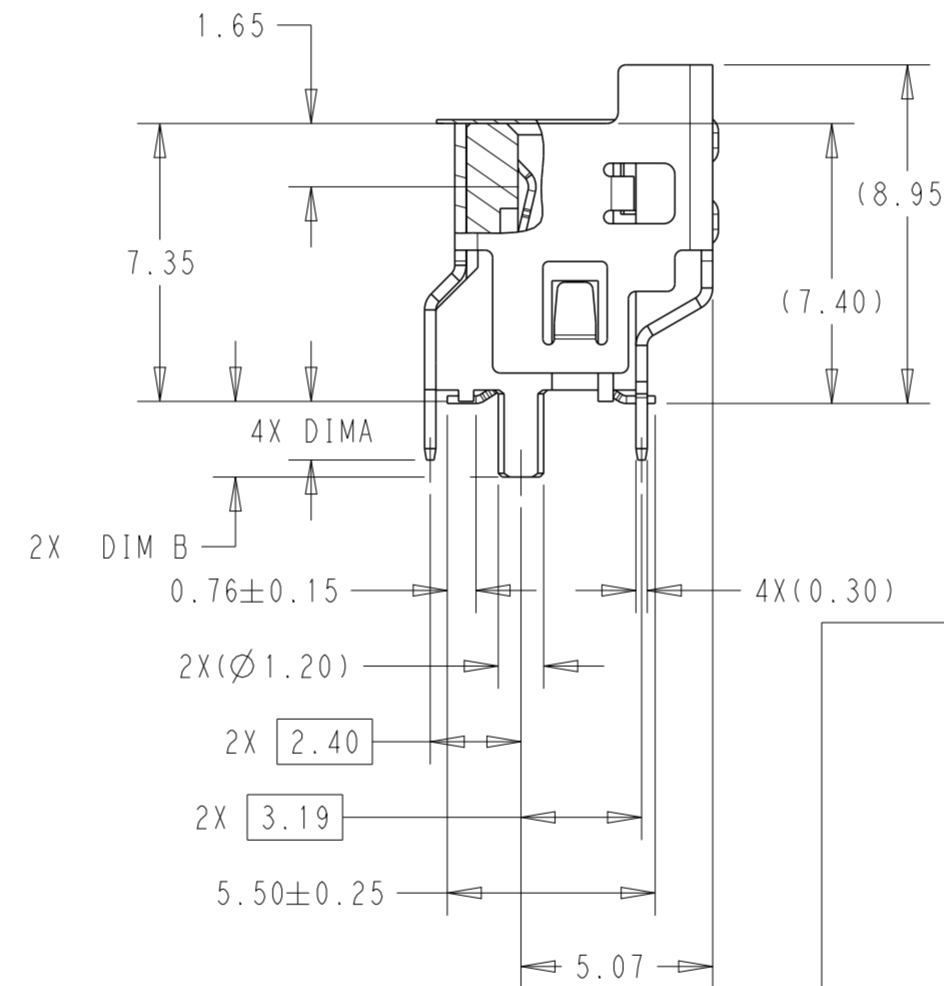
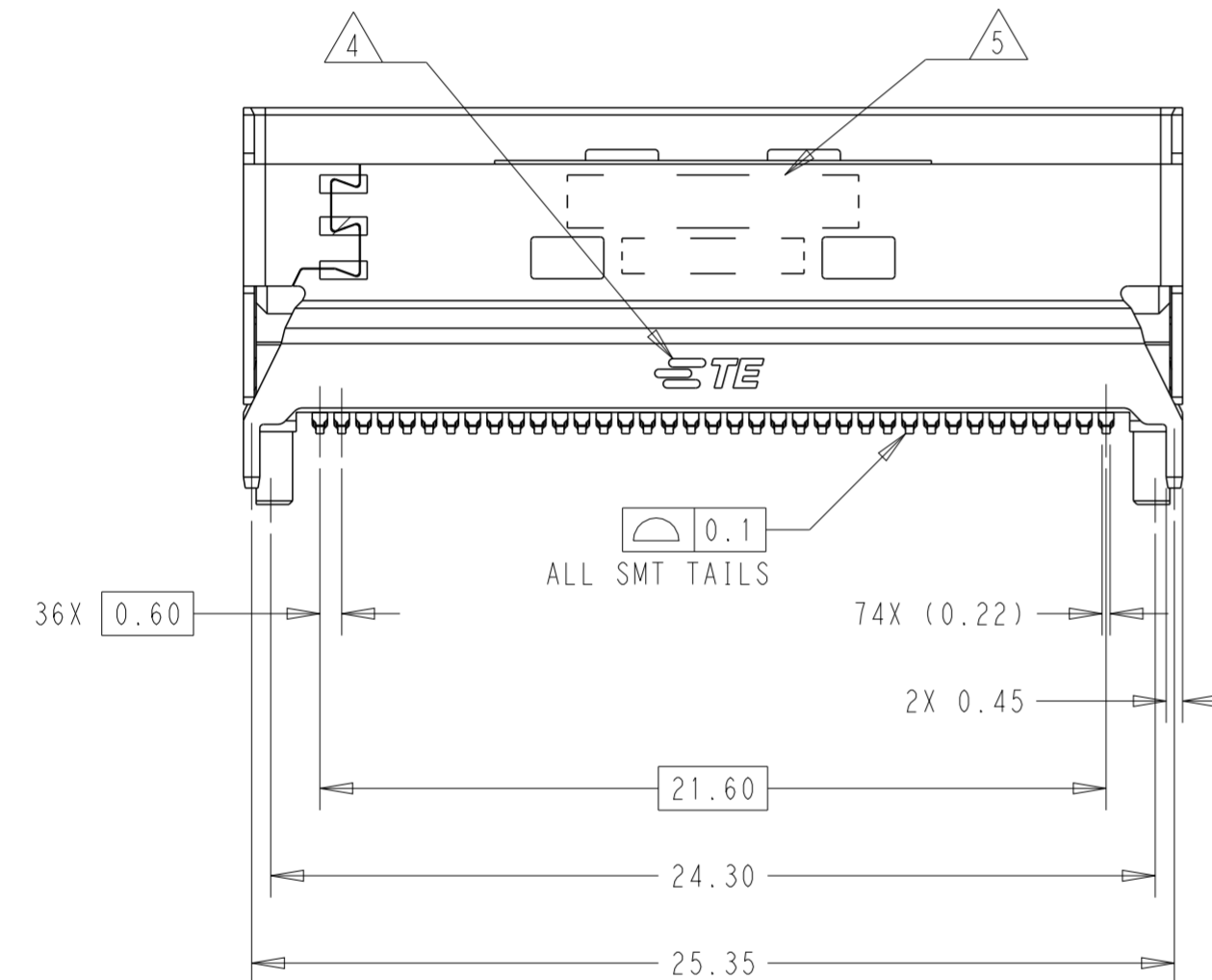
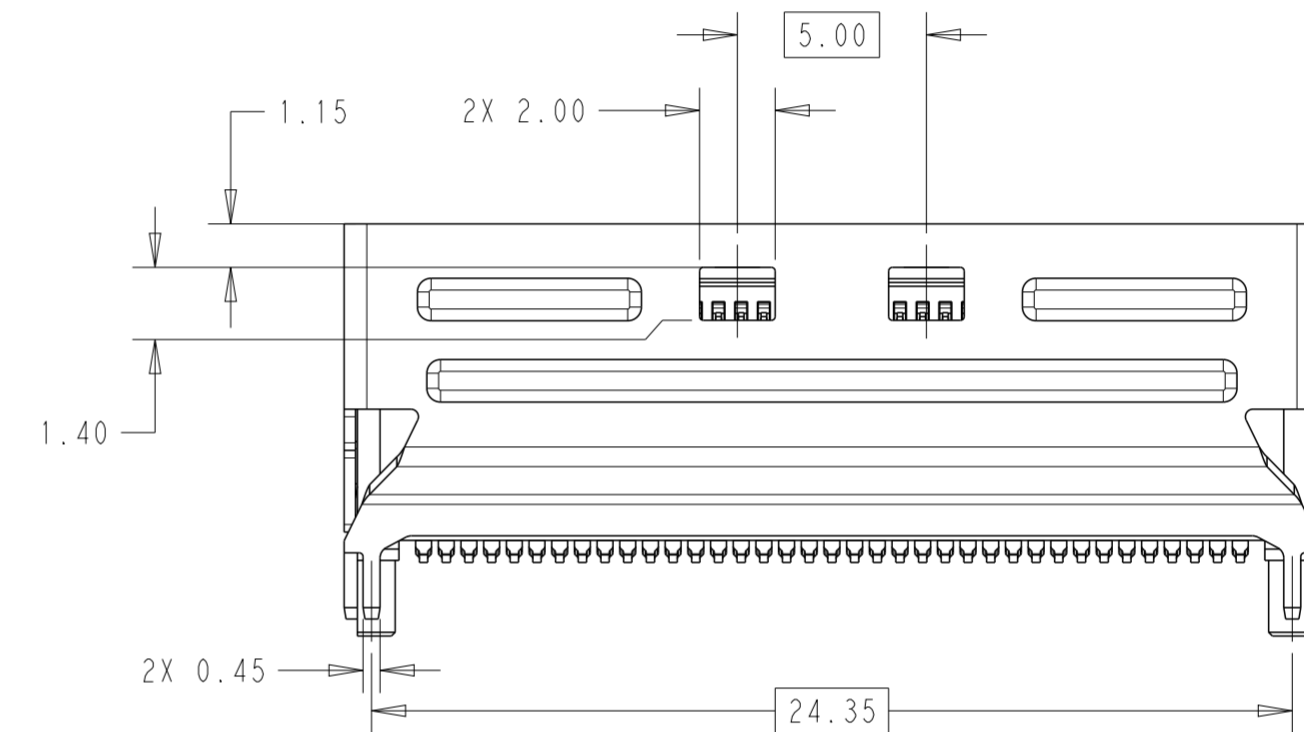

1 MATERIALS:  
 PLASTICS: HIGH TEMPERATURE THERMOPLASTIC UL94V-0, COLOR: BLACK.  
 SHELL: STAINLESS STEEL  
 CONTACT: COPPER ALLOY  
 PICK AND PLACE TAPE: POLYIMIDE FILM.

2 FINISH:  
 TERMINAL: CONTACT AREA: SELECTED GOLD PLATING, SEE TABLE.  
 SOLDER AREA: MATTE TIN PLATING 100u".  
 SHELL: UNDERPLATING: NICKEL PLATING 50u" MIN OVERALL.

3 HALOGEN REQUIREMENT MEET CODE 2: LOW BR/CL AS DEFINED IN TEC-138-702.

4 TE CONNECTIVITY LOGO MARKED IN APPROXIMATE AREA SHOWN.

5 PART NUMBER AND DATE CODE MARKED IN APPROXIMATE AREA SHOWN.

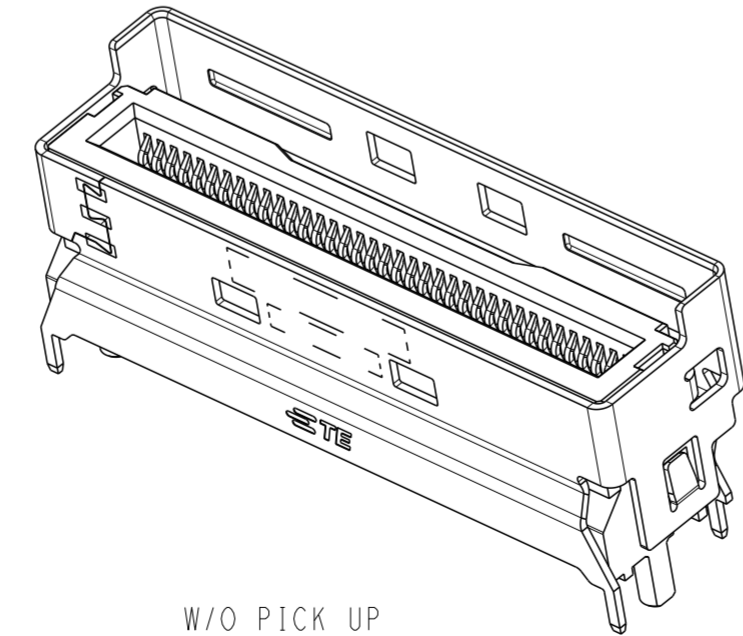

W/O PICK UP SCALE 4:1

Q'TY /CARTON (PCS)	POKET TAPE PITCH(MM)	Q'TY /REEL (PCS)	CAP OPTION	CONTACT FINISH	DIM B	DIM A	PART NUMBER
800	20	200	W/O PICK UP	30u" GOLD	2.00	1.50	4-2379397-5
					1.20	1.20	1-2379397-9
			W/CAP	30u" GOLD	2.00	4.20	1-2379397-8
					2.00	3.00	1-2379397-7
					2.00	2.20	1-2379397-6
					2.00	1.50	1-2379397-5
			W/PICK AND PLACE TAPE	15u" GOLD	1.20	1.20	3-2379397-9
					2.00	4.20	1-2379397-4
					2.00	3.00	1-2379397-3
					2.00	2.20	1-2379397-2
					2.00	1.50	1-2379397-1
					1.20	1.20	2379397-9
			W/PICK AND PLACE TAPE	30u" GOLD	2.00	4.20	2379397-8
					2.00	3.00	2379397-7
					2.00	2.20	2379397-6
					2.00	1.50	2379397-5
1.20	1.20	2-2379397-9					
2.00	4.20	2379397-4					
W/PICK AND PLACE TAPE	15u" GOLD	2.00	3.00	2379397-3			
		2.00	2.20	2379397-2			
		2.00	1.50	2379397-1			
		2.00	1.50	2379397-1			

THIS DRAWING IS A CONTROLLED DOCUMENT.

DIMENSIONS: mm	TOLERANCES UNLESS OTHERWISE SPECIFIED:
0 PLC ±	1 PLC ±
2 PLC ±0.20	3 PLC ±0.10
4 PLC ±	ANGLES ±2°
MATERIAL	FINISH

DWN	24SEP2020
CHK	LEO LI 24SEP2020
APVD	DAVID ZHANG 24SEP2020
PRODUCT SPEC	108-60133
APPLICATION SPEC	114-60030
WEIGHT	-
CUSTOMER DRAWING	SCALE 5:1

**STE** TE Connectivity

NAME: MINI COOL EDGE IO INTEGRATED CONN.  
 0.6 PITCH, VERTICAL STANDARD  
 74P, SMT TYPE, 85ohm

SIZE: A2 CAGE CODE: 00779 DRAWING NO: C-2379397 RESTRICTED TO: -

SHEET 1 OF 5 REV A

P	LTR	DESCRIPTION	DATE	DWN	APVD
-	-	SEE SHEET 1	-	-	-

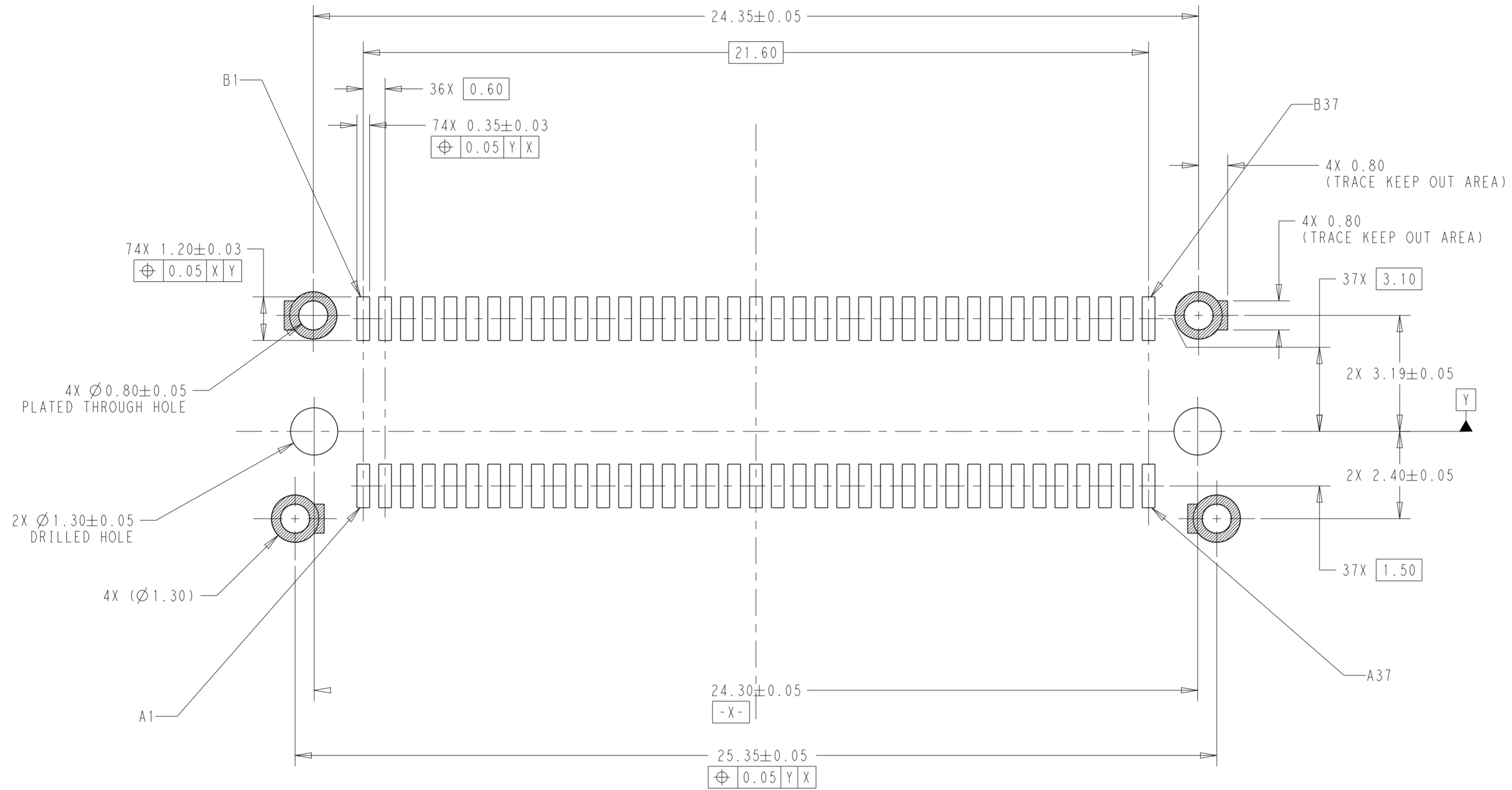

RECOMMENDED PCB LAYOUT  
AND TRACE KEEP OUT AREA  
SCALE 10:1

THIS DRAWING IS A CONTROLLED DOCUMENT.		DWN LEO LI 24SEP2020	TE Connectivity																						
DIMENSIONS: mm		CHK DAVID ZHANG 24SEP2020																							
TOLERANCES UNLESS OTHERWISE SPECIFIED:		APVD DAVID ZHANG 24SEP2020	NAME MINI COOL EDGE IO INTEGRATED CONN. 0.6 PITCH, VERTICAL STANDARD 74P, SMT TYPE, 85ohm																						
<table border="0"> <tr> <td>0 PLC</td> <td>±</td> <td></td> </tr> <tr> <td>1 PLC</td> <td>±</td> <td></td> </tr> <tr> <td>2 PLC</td> <td>±0.20</td> <td></td> </tr> <tr> <td>3 PLC</td> <td>±0.10</td> <td></td> </tr> <tr> <td>4 PLC</td> <td>±</td> <td></td> </tr> <tr> <td>ANGLES</td> <td></td> <td>±2°</td> </tr> <tr> <td>FINISH</td> <td></td> <td></td> </tr> </table>		0 PLC	±		1 PLC	±		2 PLC	±0.20		3 PLC	±0.10		4 PLC	±		ANGLES		±2°	FINISH			PRODUCT SPEC 108-60133	SIZE A2	
0 PLC	±																								
1 PLC	±																								
2 PLC	±0.20																								
3 PLC	±0.10																								
4 PLC	±																								
ANGLES		±2°																							
FINISH																									
MATERIAL		APPLICATION SPEC 114-60030	CAGE CODE 00779	DRAWING NO C-2379397																					
		WEIGHT -	RESTRICTED TO -																						
		CUSTOMER DRAWING	SCALE 5:1	SHEET 2 OF 5																					
			REV A																						

P	LTR	DESCRIPTION	DATE	DWN	APVD
-	-	SEE SHEET 1	-	-	-

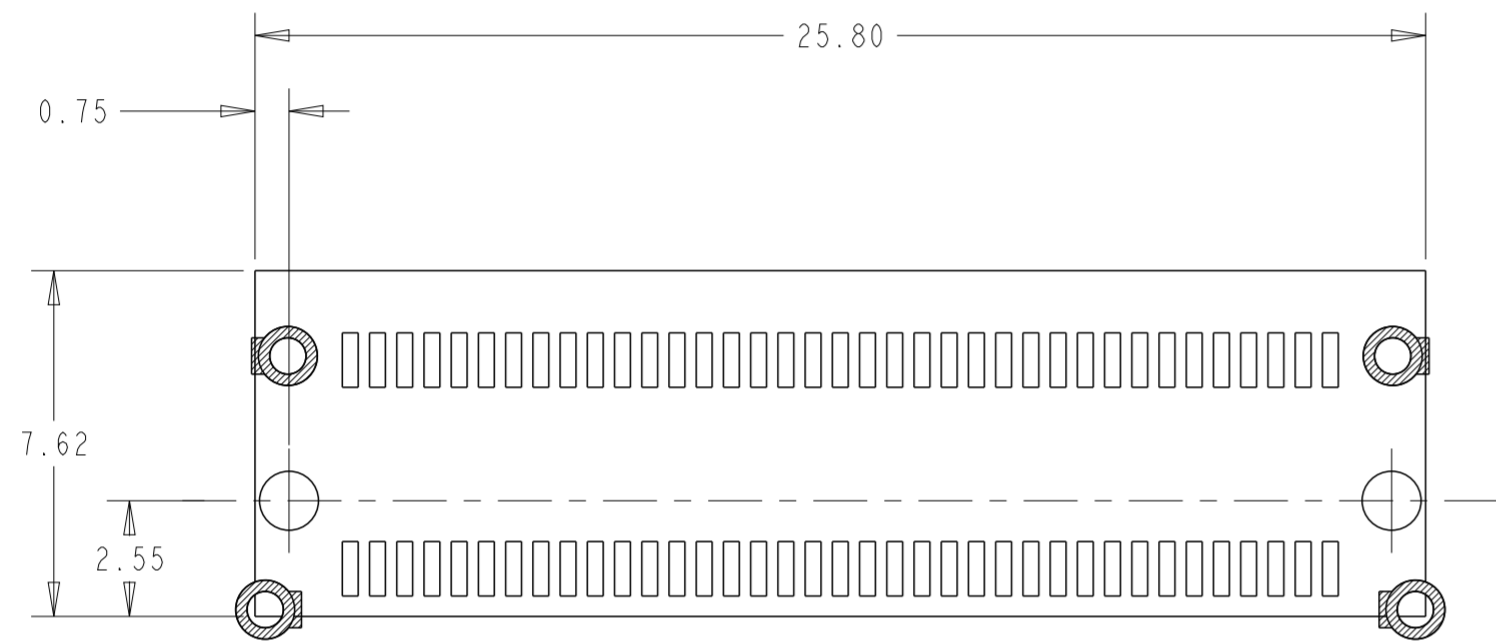

COMPONENTS KEEP OUT AREA  
LIMITATION HEIGHT: 0mm  
SCALE 6:1

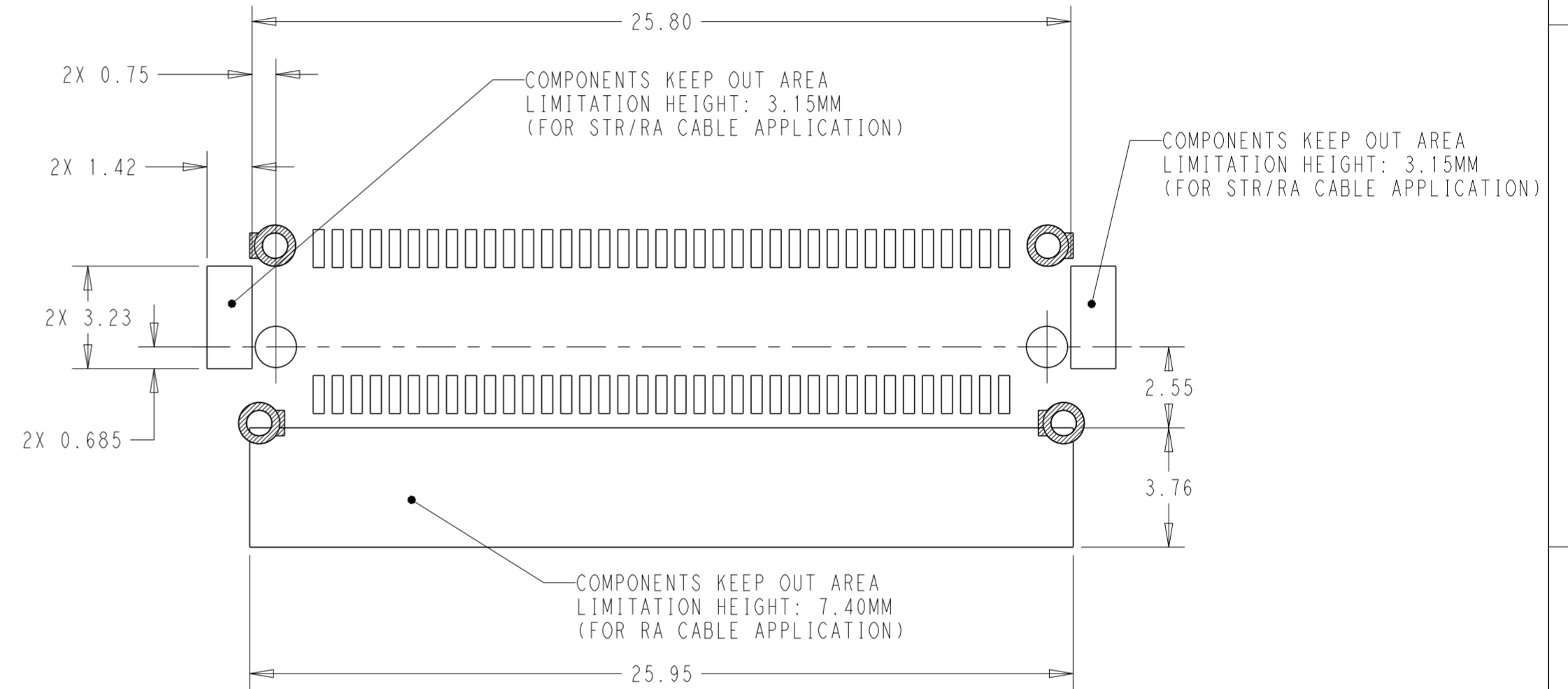



COMPONENTS KEEP OUT AREA  
SCALE 6:1

THIS DRAWING IS A CONTROLLED DOCUMENT.		DWN LEO LI 24SEP2020	TE Connectivity	
DIMENSIONS: mm		CHK DAVID ZHANG 24SEP2020		
TOLERANCES UNLESS OTHERWISE SPECIFIED:		APVD DAVID ZHANG 24SEP2020	NAME MINI COOL EDGE IO INTEGRATED CONN. 0.6 PITCH, VERTICAL STANDARD 74P, SMT TYPE, 85ohm	
0 PLC ±	1 PLC ±	PRODUCT SPEC 108-60133	SIZE A2	CAGE CODE 00779
2 PLC ±0.20	3 PLC ±0.10	APPLICATION SPEC 114-60030	DRAWING NO C-2379397	RESTRICTED TO -
4 PLC ±	ANGLES ±2°	WEIGHT -	SCALE 5:1 SHEET 3 OF 5 REV A	
MATERIAL -	FINISH -	CUSTOMER DRAWING		

P	LTR	DESCRIPTION	DATE	DWN	APVD
-		SEE SHEET 1	-	-	-

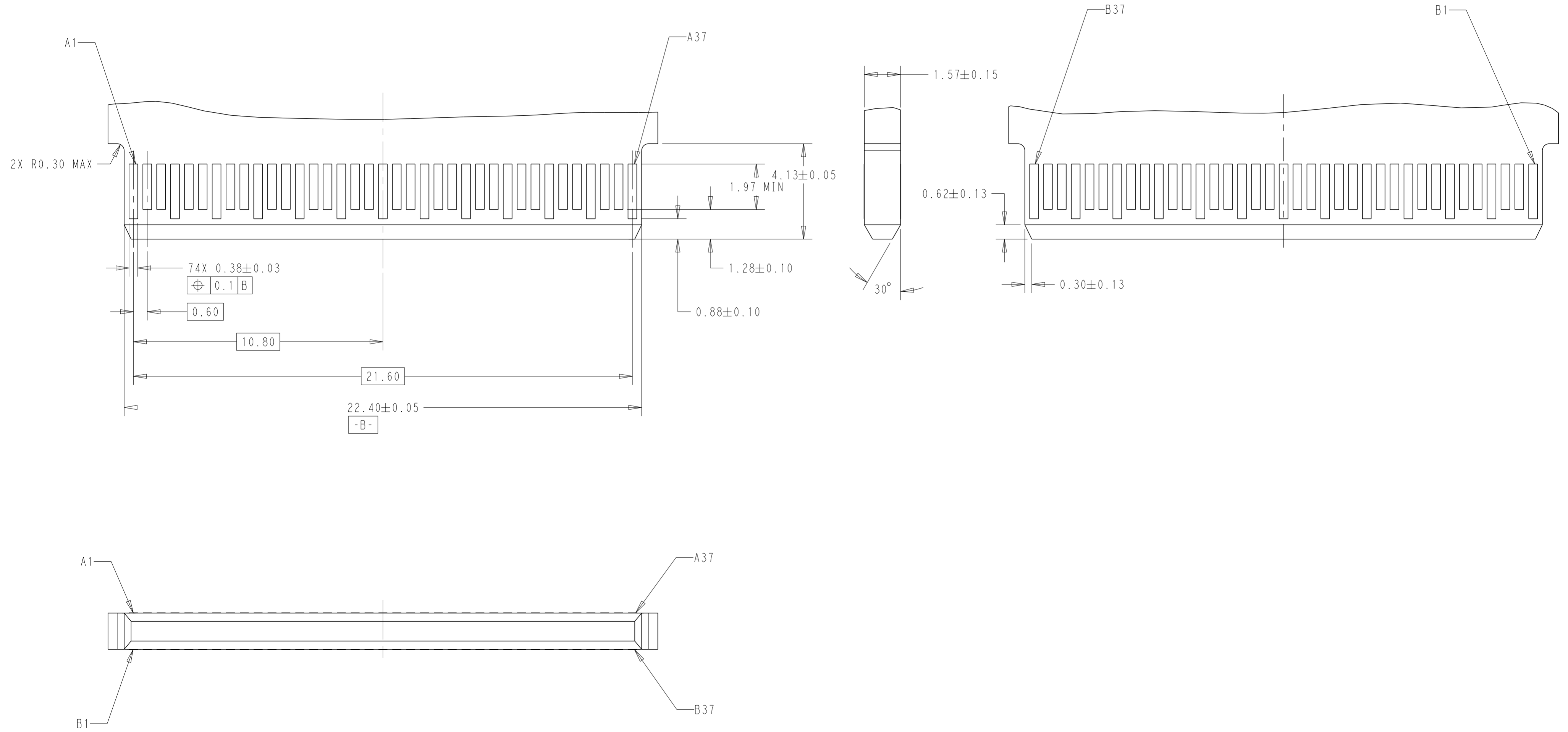
# RECOMMENDED AIC CARD DIMENSIONS



THIS DRAWING IS A CONTROLLED DOCUMENT.		DWN LEO LI 24SEP2020	 TE Connectivity																						
DIMENSIONS: mm		CHK DAVID ZHANG 24SEP2020																							
TOLERANCES UNLESS OTHERWISE SPECIFIED:		APVD DAVID ZHANG 24SEP2020	NAME MINI COOL EDGE IO INTEGRATED CONN. 0.6 PITCH, VERTICAL STANDARD 74P, SMT TYPE, 85ohm																						
<table border="1"> <tr> <td>0 PLC</td> <td>±</td> <td>-</td> </tr> <tr> <td>1 PLC</td> <td>±</td> <td>-</td> </tr> <tr> <td>2 PLC</td> <td>±</td> <td>0.20</td> </tr> <tr> <td>3 PLC</td> <td>±</td> <td>0.10</td> </tr> <tr> <td>4 PLC</td> <td>±</td> <td>-</td> </tr> <tr> <td>ANGLES</td> <td>±</td> <td>2°</td> </tr> <tr> <td>FINISH</td> <td>-</td> <td>-</td> </tr> </table>		0 PLC	±	-	1 PLC	±	-	2 PLC	±	0.20	3 PLC	±	0.10	4 PLC	±	-	ANGLES	±	2°	FINISH	-	-	PRODUCT SPEC 108-60133	SIZE A2	
0 PLC	±	-																							
1 PLC	±	-																							
2 PLC	±	0.20																							
3 PLC	±	0.10																							
4 PLC	±	-																							
ANGLES	±	2°																							
FINISH	-	-																							
MATERIAL		APPLICATION SPEC 114-60030	CAGE CODE 00779	DRAWING NO C-2379397	RESTRICTED TO -																				
		WEIGHT -	SCALE 5:1		SHEET 4 OF 5																				
		CUSTOMER DRAWING		REV A																					