

Insert
Mini-Coax 6 Channel Block
Right Angle

23C25G-40ML5

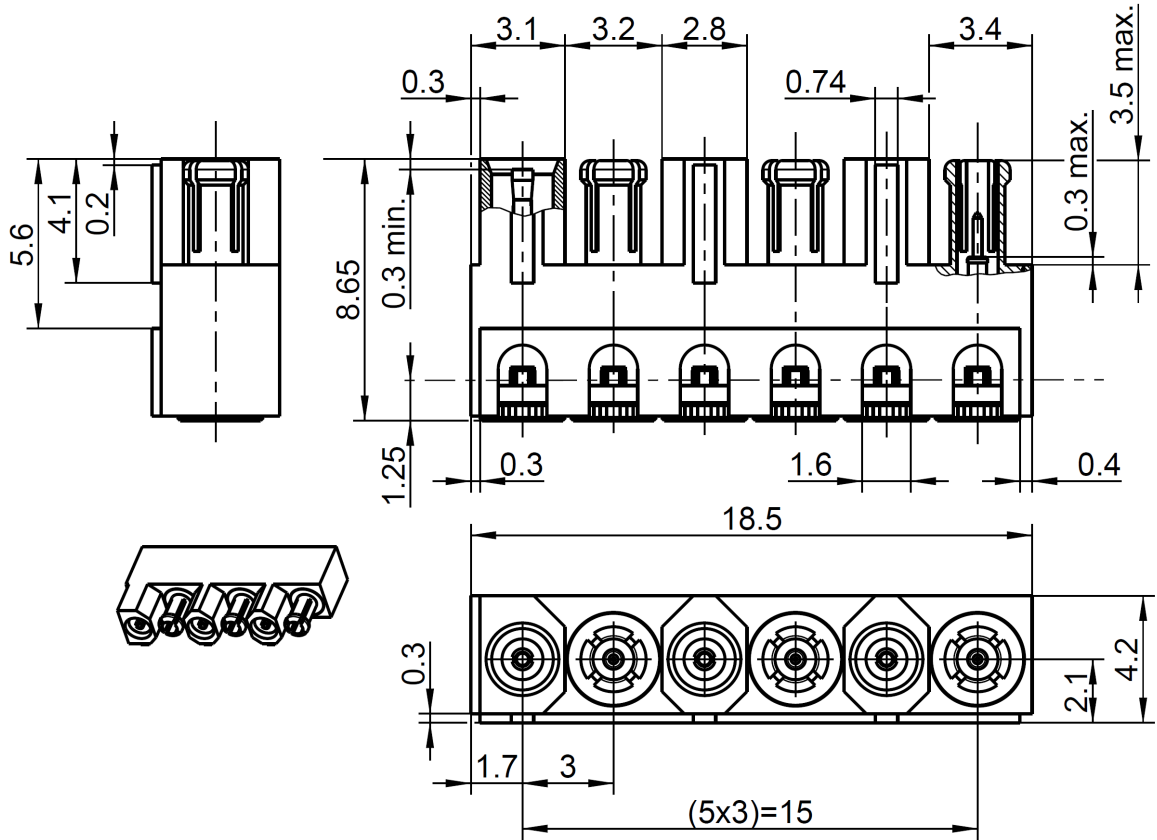

All dimensions are in mm; tolerances according to ISO 2768 m-H

Interface

According to Rosenberger Mini-Coax

Documents

PCB - Layout B 501B

Material and plating

Connector parts

- Center contact
- Outer contact male
- Outer contact female
- Body
- Dielectric

Material

- CuBe or equiv.
- CuBe
- Brass
- Brass
- PTFE

Plating

- AuroDur®, gold plated
- AuroDur®, gold plated
- AuroDur®, gold plated
- AuroDur®, gold plated

Dieses Dokument ist urheberrechtlich geschützt • This document is protected by copyright • Rosenberger Hochfrequenztechnik GmbH & Co. KG

RF_35/08.13/6.1

Insert
Mini-Coax

6 Channel Block
Right Angle

23C25G-40ML5

Electrical data

Impedance 50 Ω
 Frequency DC to 40 GHz
 Return loss ≥ 25 dB @ DC to 3 GHz
 ≥ 20 dB @ 3 GHz to 6 GHz
 ≥ 16 dB @ 6 GHz to 20 GHz
 ≥ 12 dB @ 20 GHz to 40 GHz
 Insertion loss ≤ 0.04 x √f [GHz] dB
 Insulation resistance ≥ 1GΩ
 Center contact resistance ≤ 10 mΩ
 Outer contact resistance ≤ 3 mΩ
 Test voltage (at sea level) 750 V rms
 Working voltage (at sea level) 500 V rms
 RF-leakage ≥ 80 dB @ DC to 1 GHz
 ≥ 60 dB @ 1 GHz to 4 GHz

- Connector only, VSWR in application depends decisive on PCB layout -

Mechanical data

Mating cycles ≥ 500
 Engagement force max. 40 N typical 30 N
 Extraction force max. 45 N typical 30 N

Environmental data

Temperature range -40 °C to +125 °C
 Climatic category IEC 60068-2-1 40/85/21
 Dry heat IEC 60068-2-2
 Damp heat IEC 60068-2-78
 Shock IEC 60068-2-27 (50g halfsinus, 2 shocks/axis during 11 sec.)
 Max. soldering temperature IEC 61760-1, +260 °C for 10 sec.
 RoHS compliant

Tooling

N/A

Weight

3 g/pce

While the information has been carefully compiled to the best of our knowledge, nothing is intended as representation or warranty on our part and no statement herein shall be construed as recommendation to infringe existing patents. In the effort to improve our products, we reserve the right to make changes judged to be necessary.

Draft	Date	Approved	Date	Rev.	Engineering change number	Name	Date
Martin Moder	22.11.16	Herbert Babinger	29.05.19	b00	19-0918	A. Youmsi	29.05.19
Rosenberger Hochfrequenztechnik GmbH & Co. KG P.O.Box 1260 D-84526 Tittmoning Germany www.rosenberger.de						Tel. : +49 8684 18-0 Email : info@rosenberger.de	
							Page 2 / 2