

NOTES:

24-000-1018-90

Materials: SST. corrosion-resistant, Non Magnetic 303, per ASTM A484 and A582. Beryllium Copper per ASTM-B-196, QQ-C-530 Oxide-Noryl (tm), Per MIL-P-46129

Finish: Center Conductors and solder components shall be plated per MIL-G-45204 Type II, Class 1 over Nickel plate per QQ-N-290. Body and Body components shall be passivated per ASTM A380.

Frequency: DC-40GHz

VSWR: 1.28 to 40GHz

Insertion Loss: .05(SQRT(F(GHz)))

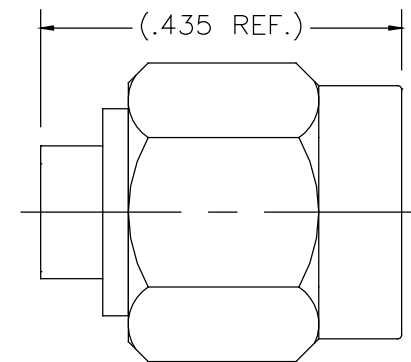

LTR	DESCRIPTION	DATE	APPR.	DRAWN LMW	CHECKED	USED ON	 SRI CONNECTOR GAGE CO. 751 NORTH DRIVE MELBOURNE FL. 32934		
-	REL	12/01		APPR.	SCALE	24-000-1018-90	TITLE		
				UNLESS OTHERWISE SPECIFIED: 1. REMOVE ALL BURRS 2. BREAK ALL CORNERS & EDGES .005 R. MAX 3. CHAMFER 1st & LAST THREADS 45° 4. SURFACE ROUGHNESS 63 MIL-STD-10 5. DIAMETERS ON COMMON CENTERS TO BE CONCENTRIC WITHIN T.I.R. 6. ALL DIMENSIONS ARE AFTER PLATING		MATERIAL	2.9mm PLUG TO 118 S/R		
				DIMENSIONS ARE IN INCHES TOLERANCES		FINISH			
				DECIMALS      FRACTIONAL      ANGULAR .X            ±.030 .XX          ±.015 .XXX        ±.005		SIZE	FSCM NO.	SHEET	DWG. NO.
						A	□HMO□1	1	24-000-1018-90