

REVISIONS				
P	LTR	DESCRIPTION	DATE	APVD
A		ECN-22-152748	11MAY2022	PZ WKH

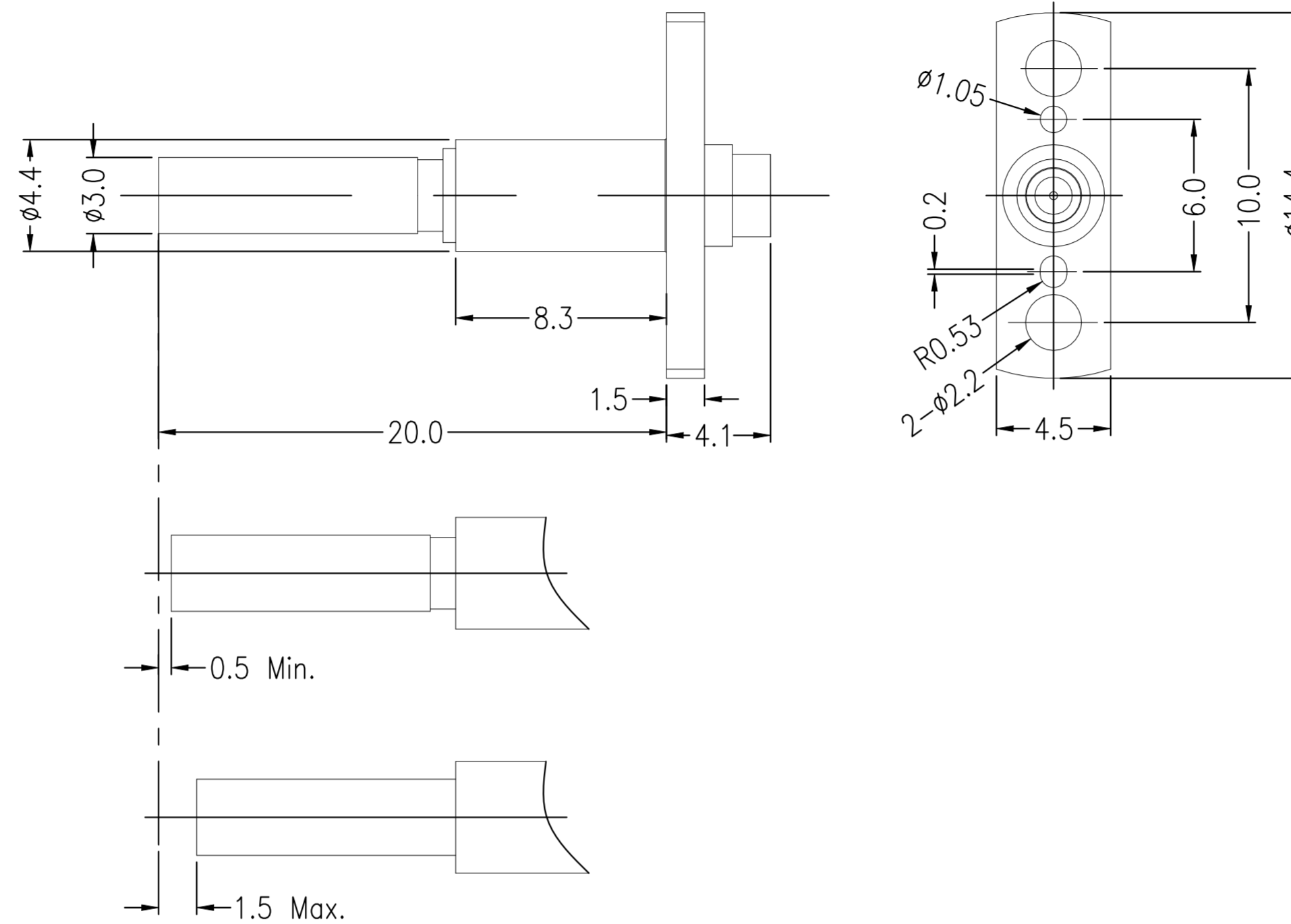

ELECTRICAL	MECHANICAL	ENVIRONMENTAL
Impedance (Ohm): <u>50</u> Frequency Range: <u>DC to 9GHz</u> Voltage Rating (Peak) @ Sea Level <u>170 V RMS</u> Insulation Resistance (MIN.) <u>500 M ohms</u> Contact Resistance (mohms MAX) Center Contact <u>50</u> Outer Contact <u>20</u> Dielectric Withstand Voltage: <u>500 V RMS Max</u> Insertion Loss : <0.6 dB @0-6GHz <0.8 dB @6-9GHz VSWR: <u>1.3 max @ DC~6GHz</u> <u>1.5 max @ 6GHz~9GHz</u>	Interface Dimension <u>SSMP TO UMCC</u> Force to Engage and Disengage Engage: <u>N/A</u> Disengage: <u>N/A</u> CONDUCTOR ELASTICITY: OUTER CONDUCTOR ELASTICITY(PRESS 1.1±0.05mm) <u>450gf~650gf</u> INNER CONDUCTOR ELASTICITY(PRESS 0.3±0.05mm) <u>150gf~300gf</u> Cable Retention Axial (Lbs) <u>N/A</u> Mating cycles <u>10000</u> cycles (UMCC SIDE) <u>500</u> cycles (SSMP)	TEMPERATURE RANGE <u>-40 °C~+85 °C</u> ROHS <u>COMPLIANT</u>

2408021-1	SPRING	STAINLESS STEEL	PASSIVATION
	CONTACT PIN	BERYLLIUM COPPER	PL.GOLD/NICKEL/COPPER
	INSULATOR	PTFE MIL-P-19468	N/A
	BODY	STAINLESS STEEL	PASSIVATION
	PART NUMBER	MATERIAL	PLATING

THIS DRAWING IS A CONTROLLED DOCUMENT.		DWN	18FEB2022	
		CHK	18FEB2022	
		APVD	18FEB2022	
		PRODUCT SPEC		
DIMENSIONS: mm		TOLERANCES UNLESS OTHERWISE SPECIFIED: 0 PLC ± - 1 PLC ± 0.3 2 PLC ± 0.2 3 PLC ± 0.1 4 PLC ± - ANGLES ± 5°		NAME SSMP TO RF UMCC ADAPTOR
MATERIAL -		FINISH -		SIZE A2
		WEIGHT -		CAGE CODE 00779
		CUSTOMER DRAWING		DRAWING NO C=2408021
		SCALE 1:1		RESTRICTED TO -
		SHEET 1 OF 1		REV A