

THIS DOCUMENT IS THE PROPERTY OF KEYSTONE ELECTRONICS CORP. AND SHALL NOT BE REPRODUCED, DISTRIBUTED OR USED AS A BASIS FOR MANUFACTURE WITHOUT PRIOR WRITTEN PERMISSION FROM KEYSTONE ELECTRONICS CORP.

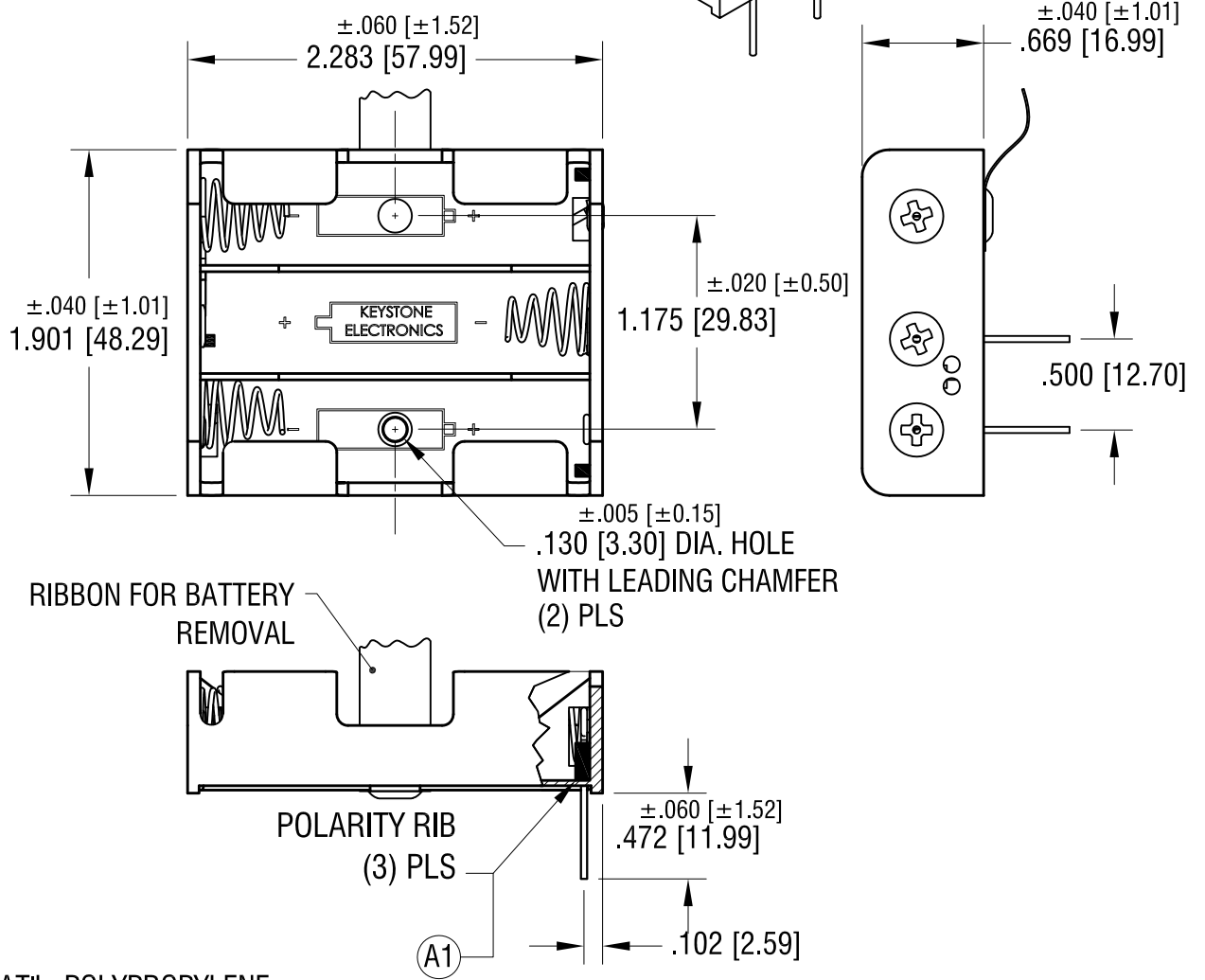
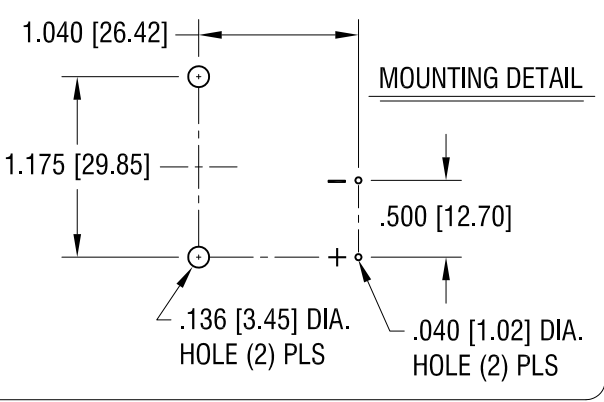
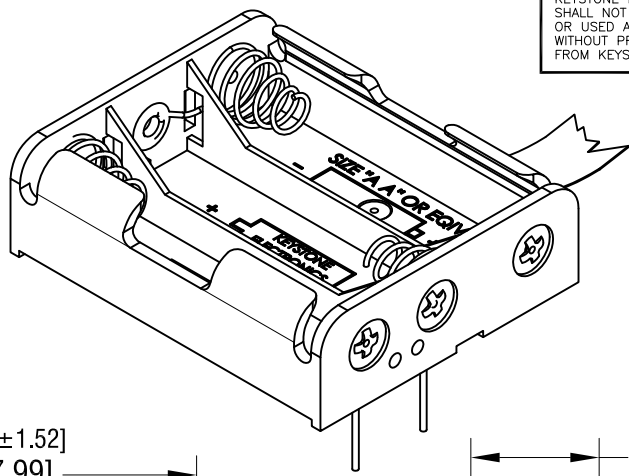

NOTE:

1. HOLDER: MAT'L: POLYPROPYLENE
2. SPRING: MAT'L: MUSIC WIRE, .027 [0.70] DIA.
3. PC TERMINALS: MAT'L: BRASS, .032 [0.81] DIA.
4. RIBBON: MAT'L: NYLON, RED

SHOW POLARITY STOPPER (A1)
 CHANGE AS PER ECN 22-033

DATE	DESCRIPTION	REV.
2.08.22	CHANGE AS PER ECN 22-033	A

KEYSTONE ELECTRONICS CORP.			
www.keyelco.com • NEW HYDE PARK, NY 11040 • Tel (516) 328-7500			
PART NAME			
PC BATTERY HOLDER (3) 'AA' W/ RIBBON			
MATERIAL			
AS NOTED			
FINISH		DRN BY	DATE
NICKEL PLATE		BOONE	12.01.03
		APP'D	SCALE
		LN	1X
TOLERANCES	INCH [MM]	CODE	DWG NO.
DECIMAL	± .015 [± 0.38]	C	2464RB
ANGULAR	± 1°		
UNLESS OTHERWISE SPECIFIED			