

THIS DOCUMENT IS THE PROPERTY OF KEYSTONE ELECTRONICS CORP. AND SHALL NOT BE REPRODUCED, DISTRIBUTED OR USED AS A BASIS FOR MANUFACTURE WITHOUT PRIOR WRITTEN PERMISSION FROM KEYSTONE ELECTRONICS CORP.

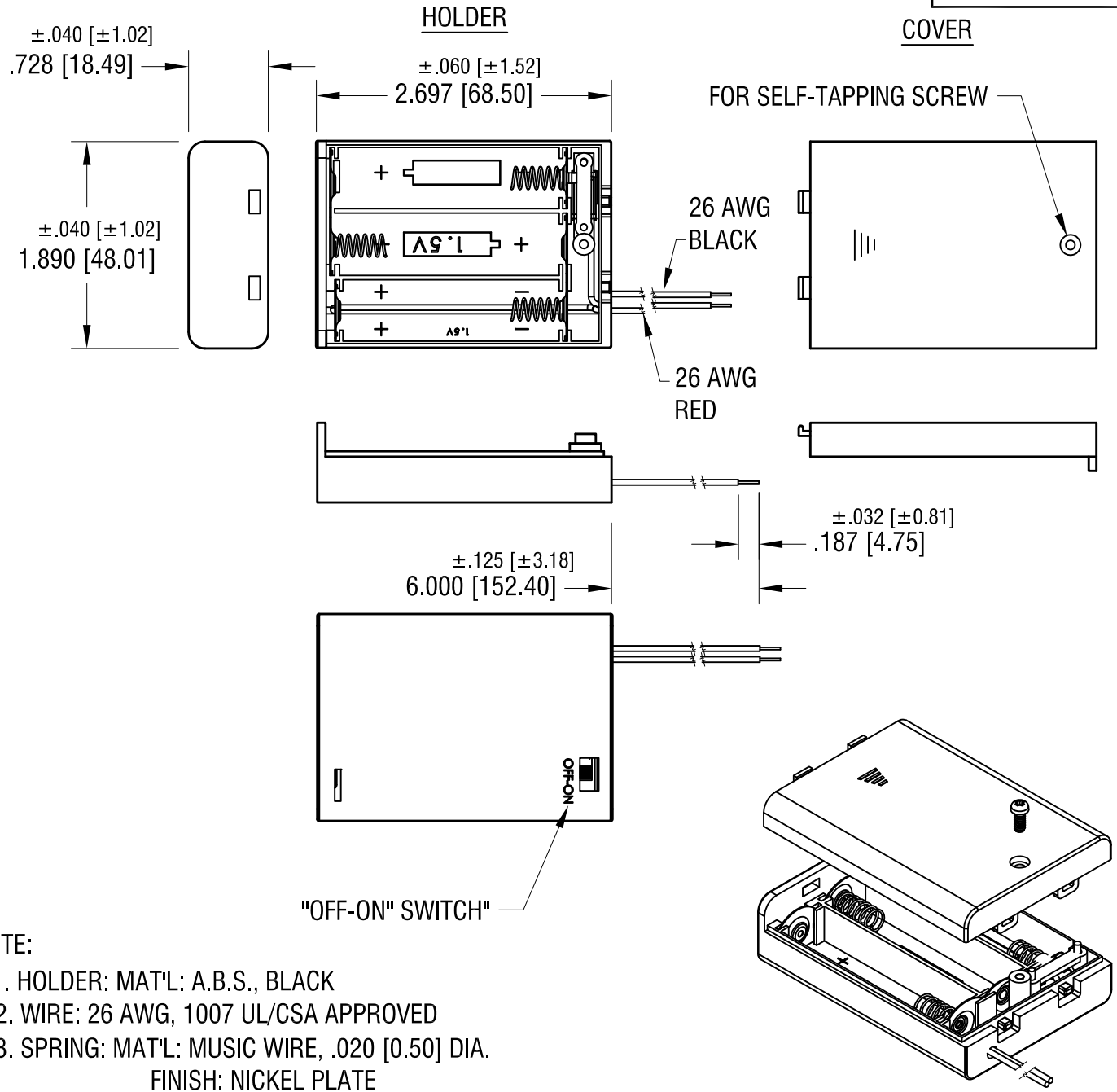

**NOTE:**

1. HOLDER: MAT'L: A.B.S., BLACK
2. WIRE: 26 AWG, 1007 UL/CSA APPROVED
3. SPRING: MAT'L: MUSIC WIRE, .020 [0.50] DIA.  
FINISH: NICKEL PLATE
4. "OFF-ON" SWITCH ADDED BETWEEN NEGATIVE SPRING AND BLACK WIRE

<b>KEYSTONE ELECTRONICS CORP.</b>			
www.keyelco.com • NEW HYDE PARK, NY 11040 • Tel (516) 328-7500			
PART NAME			
BATTERY HOLDER AND COVER (3) 'AA'			
MATERIAL			
AS NOTED			
FINISH		DRN BY	DATE
AS NOTED		NT	7.20.16
		APP'D	SCALE
		RH	1X
TOLERANCES	INCH [MM]	CODE	DWG NO.
DECIMAL	± .015 [± 0.38]	C	<b>2487SW</b>
ANGULAR	± 1°		
UNLESS OTHERWISE SPECIFIED			

DATE	DESCRIPTION	REV.