

THIS DOCUMENT IS THE PROPERTY OF
KEYSTONE ELECTRONICS CORP. AND
SHALL NOT BE REPRODUCED, DISTRIBUTED
OR USED AS A BASIS FOR MANUFACTURE
WITHOUT PRIOR WRITTEN PERMISSION
FROM KEYSTONE ELECTRONICS CORP.

ACTUAL SIZE

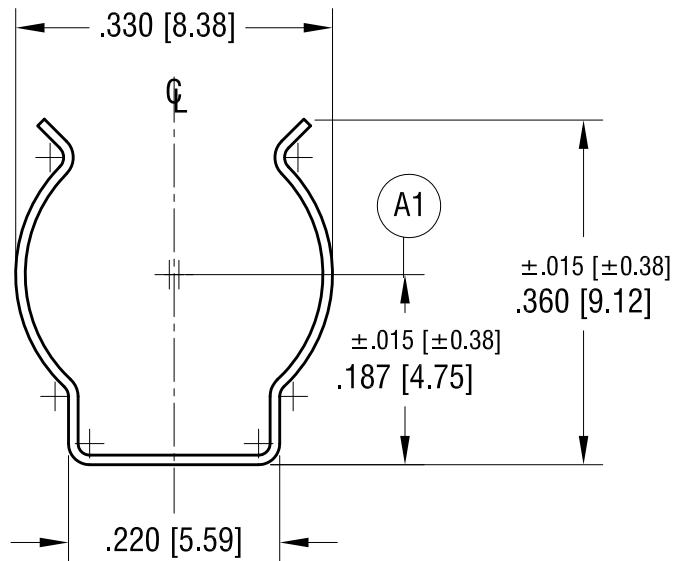
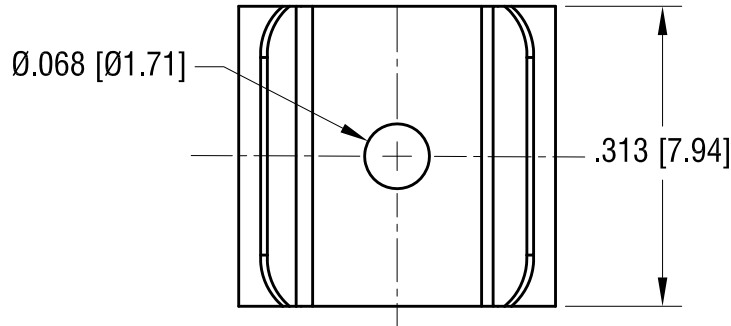

NOTE:
HEAT TREAT TO SPRING TEMPER

KEYSTONE ELECTRONICS CORP.

www.keyelco.com • NEW HYDE PARK, NY 11040 • Tel (516) 328-7500

PART NAME

BATTERY CLIP FOR 'AAAA' CELL

MATERIAL

.010 [0.25] TH'K SPRING STEEL

FINISH

NICKEL PLATE

DRN BY

NT

DATE

5.08.18

APP'D

LN

SCALE

5X

TOLERANCES

INCH [MM]

DECIMAL ±.010 [±0.25]

ANGULAR ± 2°

UNLESS OTHERWISE SPECIFIED

CODE

C

DWG NO.

251

3.20.19	A1 WAS .200±.015 CHANGE AS PER ECN 19-036	A
DATE	DESCRIPTION	REV.