

5

4

3

2

1

受控 CONTROLLED DOCUMENT					
编号 P/N	26-8012-CUST	版本 Rev	01	日期 Rel'd Date	SEP 17,09

DRAWING NO.
26-8012

REVISIONS

01	OFFICIAL RELEASE				Betty 2009.09.16 11:01:39 +0800©
	08-05-09	I	W	T	

D



Description: N (M) TO N (F) RA UG-27/U
 Part No: 26-8012
 Application: Adapter
 Crimp Tool: N/A
 Impedance: N/A
 Frequency Range: N/A
 Material: Body Brass Nickel Plated
 Nut Brass Nickel Plated
 Insulator PTFE
 Contact Brass Gold Plated
 RoHS Compliance: Yes
 Technical Detail: Refer to Emerson Document P/N 26-0000

C

B

A

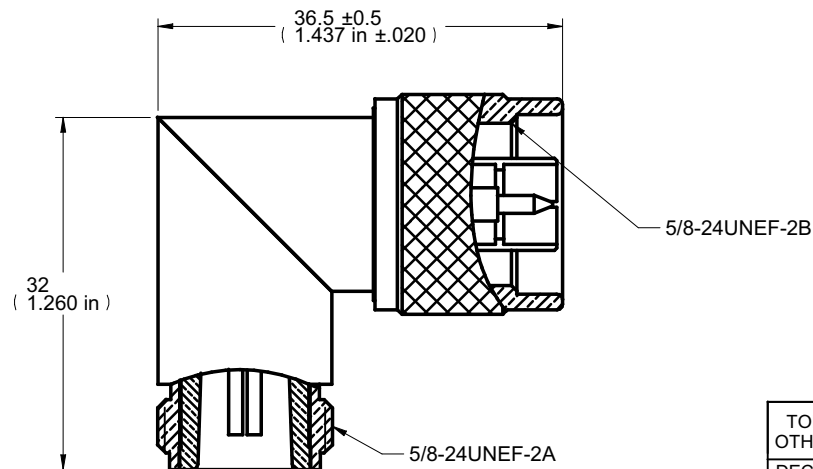

DIM OUTLINE

CUSTOMER COPY

TOLERANCE UNLESS OTHERWISE SPECIFIED		DRAWN BY IVON.W	DATE 08-05-09
DECIMALS	mm	CHECKED BY IVON.W	DATE 08-05-09
X	± 0.5	APPROVED BY THOMAS	DATE 08-05-09
X.X	± 0.3		
X.XX	± 0.1		
ANGLES	± 0.5°	U/M	mm



TITLE
N (M) TO N (F) RA UG-27/U

THIS DRAWING WAS PRODUCED BY COMPUTER,
DO NOT SCALE DRAWING OR UPDATE MANUALLY.

SHEET 1 OF 1	DRAWING NO. 26-8012	SIZE A
-----------------	------------------------	-----------

5

4

3

2

1