

5

4

3

2

1

DRAWING NO.

27-9067

## REVISIONS

01	OFFICIAL RELEASE				
	08-05-09	L	W	T	H
02	OVERALL LENGTH FORM 31.8 TO 32.8 DETAIL DIMENSION UPDATED				
	06-30-11	L	H	M	ECO-11-0127

D



Description: CPAD356 TNC(F-F)CHAS MNT 1/2"

Part No: 27-9067

Application: Adaptor

Crimp Tool: N/A

Impedance: 50OHM

Frequency Range: 0-11 GHz

Material: Body Brass Nickel Plated

Nut Brass Nickel Plated

Insulator Delrin

Contact Brass Gold Plated

RoHS Compliance: Yes

Technical Detail: Refer to Emerson Document P/N 28-0000

C

B

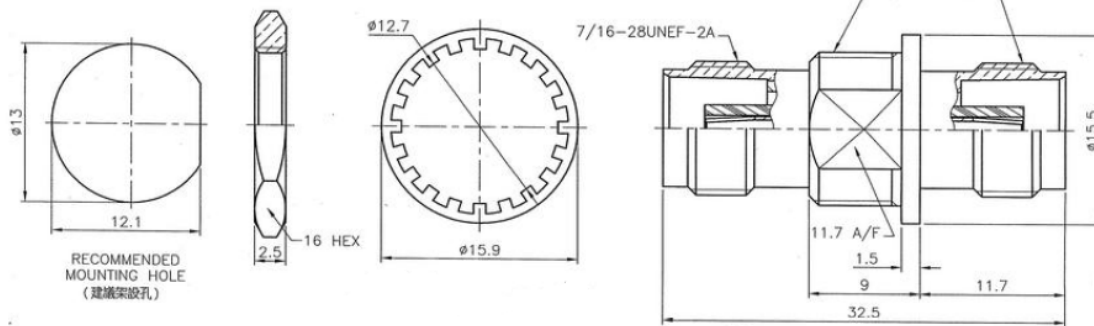

A

**DIM OUTLINE**

CUSTOMER COPY

TOLERANCE UNLESS OTHERWISE SPECIFIED		DRAWN BY Wencan Li	DATE 06-30-11
DECIMALS	mm	CHECKED BY Hu Yuge	DATE 06-30-11
X	+ 0.5	APPROVED BY Ma Lin	DATE 06-30-11
X.X	+ 0.3	U/M	mm
X.XX	+ 0.1		
ANGLES	+ 0.5-		



TITLE

CPAD356 TNC(F-F)CHAS MNT 1/2"

SHEET  
1 OF 1DRAWING NO.  
27-9067SIZE  
ATHIS DRAWING WAS PRODUCED BY COMPUTER,  
DO NOT SCALE DRAWING OR UPDATE MANUALLY.

5

4

3

2

1