

NOTES:

27-927-0000-40

Materials: SST. corrosion-resistant, Non Magnetic 303, per ASTM A484 and A582. Beryllium Copper per ASTM-B-196, QQ-C-530 Oxide-Noryl (tm), MIL-P-46129

Finish: Center Conductors and solder components shall be plated per MIL-G-45204 Type II, Class 1 over Nickel plate per QQ-N-290. Body and Body components shall be passivated per ASTM A380.

Frequency: DC-50 GHz

VSWR: 1.3 TO 50 GHz

Insertion Loss: $.05\sqrt{\text{Frequency}}$

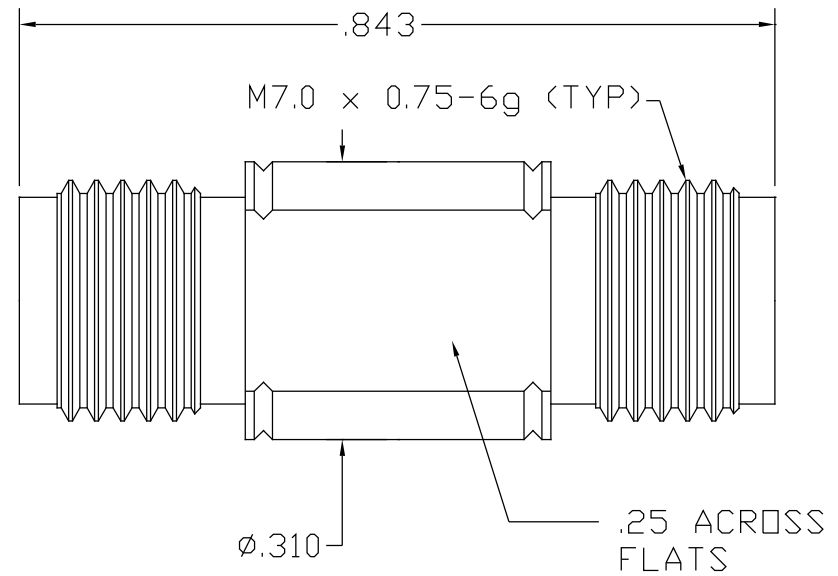

LTR	DESCRIPTION	DATE	APPR.	DRAWN	CHECKED	USED ON	SRI CONNECTOR GAGE CO. 3950 DOW ROAD MELBOURNE FL. 32934		
-	REL	07/03				27-927-0000-40	TITLE 2.4mm JACK TO 2.4mm JACK		
				UNLESS OTHERWISE SPECIFIED: 1. REMOVE ALL BURRS 2. BREAK ALL CORNERS & EDGES .005 R. MAX 3. CHAMFER 1st & LAST THREADS 45° 4. SURFACE FINISHED 32/ UNLESS OTHERWISE SPECIFIED. 5. DIAMETERS ON COMMON CENTERS TO BE CONCENTRIC WITHIN .002 T.I.R. 6. ALL DIMENSIONS ARE AFTER PLATING.		MATERIAL	SHEET 1		
						FINISH			
				DIMENSIONS ARE IN INCHES TOLERANCES		SIZE	FSCM NO.	DWG. NO.	
				DECIMALS .X ±.030 .XX ±.010 .XXX +.005	FRACTIONAL ± 1/64	ANGULAR .X° ±1°0' .X°X' ±15'	A	OHMO1	27-927-0000-40