

PART NUMBER	ITEM ① BODY	ITEM ② CONTACT	ITEM ③ INSULATOR	ITEM ④ CRIMP SLEEVE	ITEM ⑤ CUPLING NUT
28-91027	BRASS NICKEL PLATED	BRASS GOLD PLATED	DELTRIN	BRASS NICKEL PLATED	ZINC NICKEL PLATED

DRAWING NO. 28-91027					
REVISIONS					
A RELEASE FOR QUTATION					
12-16-05	Y	U	W	T	

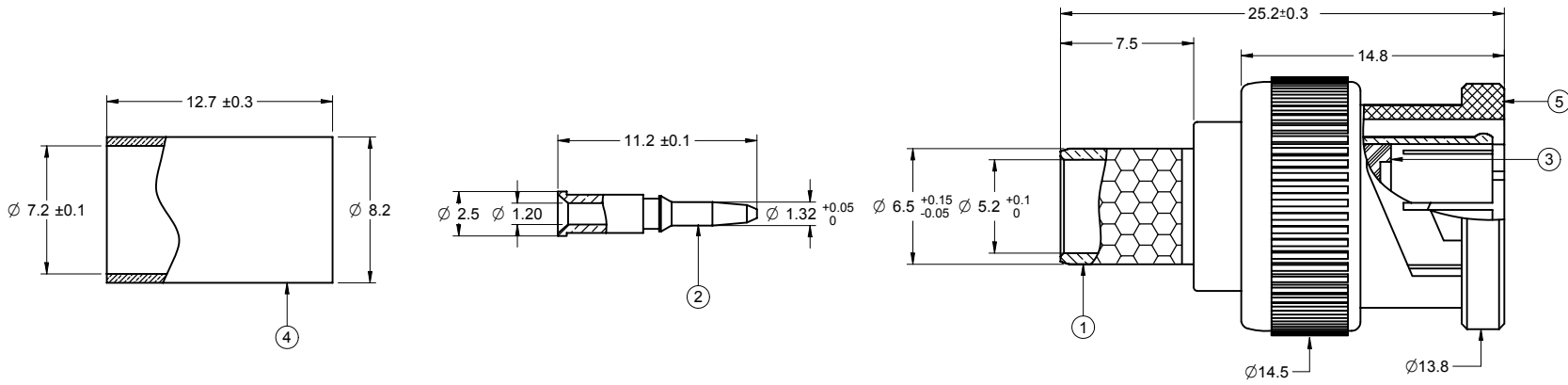

NOTES:

- ELECTRICAL SPECIFICATIONS**
 IMPEDANCE: 75 OHMS NOMINAL
 FREQUENCY RANGE: 0-2 GHz
 WORKING VOLTAGE: 500 Vrms MAX AT SEA LEVEL
 DIELECTRIC WITHSTANDING VOLTAGE: 1500 vrms AT SEA LEVEL
 CORONA LEVEL: 375 VOLTS MINIMUM AT 70,000 FEET
 CONTACT RESISTANCE: OUTER-0.2 MILLIOHMS MAXIMUM
 CENTER-2.1 MILLIOHMS MAXIMUM
 INSULATION RESISTANCE: 5000 MEGOHMS MINIMUM
- MECHANICAL SPECIFICATIONS**
 DURABILITY: 500 CYCLES MIN
 FORCE TO ENGAGE/DISENGAGE: 3 LBS. MAXIMUM
 CABLE ACCEPTABILITY: BELDEN RG6
- ENVIRONMENTAL SPECIFICATIONS**
 RECOMMENDED TEMPERATURE RANGE: -55 °C TO +85 °C
 MOISTURE RESISTANCE: MIL-STD-202

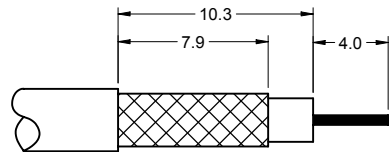

CABLE STRIP DIMENSIONS
 ASSEMBLY INSTRUCTIONS ON SHEET 2

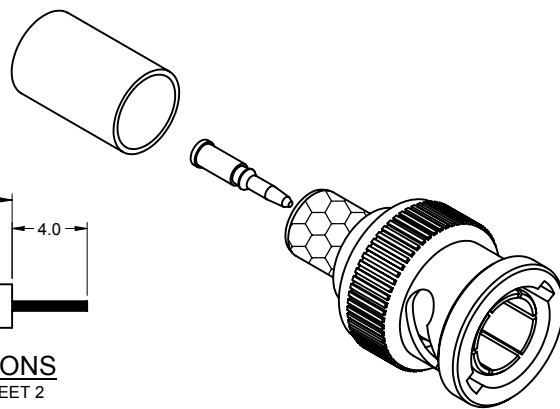

THIS DRAWING TO BE INTERPRETED
 PER ANSI Y 14.5M - 1994

COMPANY CONFIDENTIAL

TOLERANCE UNLESS OTHERWISE SPECIFIED		DRAWN BY BETTY.YU	DATE 12-12-05
DECIMALS	mm	CHECKED BY IVON.WANG	DATE 12-16-05
X	± 0.5	APPROVED BY THOMAS	DATE 12-16-05
X.X	± 0.2	U/M	mm
X.XX	± 0.05		
ANGLES	± 0.5°		

EMERSON
Network Power

Connectivity Solutions

TITLE
BNC MALE CRIMP FOR RG6/U 75Ω

THIS DRAWING WAS PRODUCED BY COMPUTER. DO NOT SCALE DRAWING OR UPDATE MANUALLY.			SHEET 1 OF 2	DRAWING NO. 28-91027	SIZE C
--	--	--	-----------------	-------------------------	-----------

5		4		3		2		1	
PART NUMBER	CABLE	CRIMP SLEEVE HEX SIZE	CRIMP CONTACT HEX SIZE	RECOMMENDED CRIMP TOOL	RECOMMENDED STRIPPER TOOL				
28-91027	BELDEN RG6	6.98	1.65	24-8856P	24-7733P				

DRAWING NO. 28-91027									
REVISIONS									
A RELEASE FOR QUOTATION									
12-16-05	Y	U	W	T					

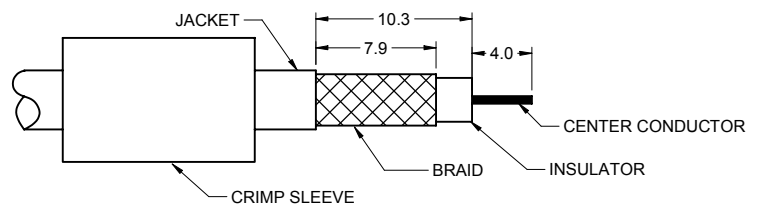
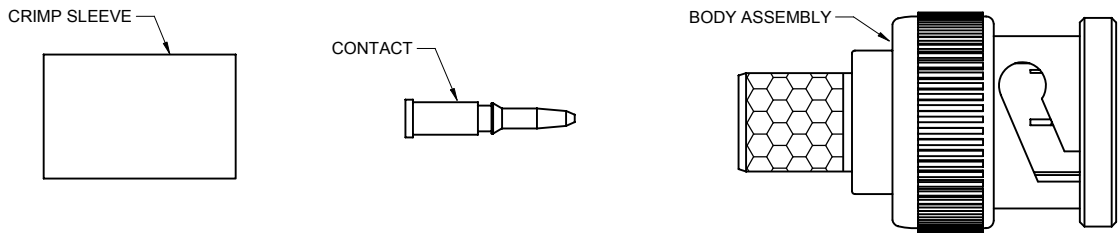

ASSEMBLY INSTRUCTIONS

1. IDENTIFY CONNECTOR PARTS. (3 PIECE PARTS.)
2. TRIM CABLE AS SHOWN. TAKING CARE NOT TO NICK THE INNER CONDUCTOR OR BRAID.
3. SLIP CRIMP SLEEVE OVER CABLE. PLACE INNER CONDUCTOR INTO CONTACT. NOTE THAT THE END OF CONTACT AND INNER INSULATOR MUST BE BUTTING AND SQUARE. CRIMP WITH APPROPRIATE TOOLING.
4. FLAIR OUTER BRAID AND GENTLY BUT FIRMLY PUSH THE CONTACT INTO THE CONNECTOR HOUSING UNTIL A GENTLE SNAP IS FELT, INDICATING THE CONTACT IS IN PLACE. SLIP THE CRIMP SLEEVE IN PLACE, BUTTING THE FLANGE AGAINST THE CONNECTOR BODY AND CRIMP WITH APPROPRIATE TOOLING.

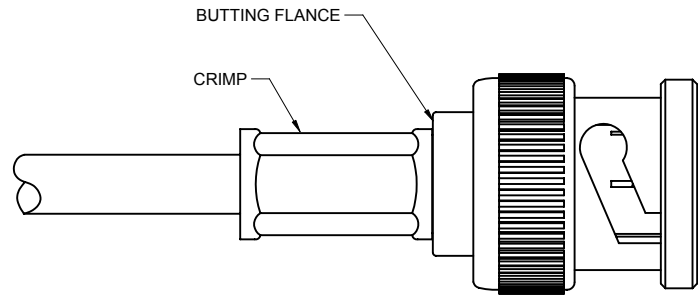
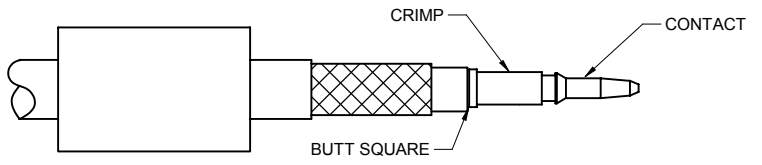

THIS DRAWING TO BE INTERPRETED PER ANSI Y 14.5M - 1994

COMPANY CONFIDENTIAL

TOLERANCE UNLESS OTHERWISE SPECIFIED		DRAWN BY BETTY.YU		DATE 12-12-05	
DECIMALS	mm	CHECKED BY IVON.WANG		DATE 12-16-05	
X	± 0.5	APPROVED BY THOMAS		DATE 12-16-05	
X.X	± 0.2				
X.XX	± 0.05				
ANGLES	± 0.5°	U/M	mm		

EMERSON
Network Power

Connectivity Solutions

TITLE
BNC MALE CRIMP FOR RG6/U 75Ω

THIS DRAWING WAS PRODUCED BY COMPUTER. DO NOT SCALE DRAWING OR UPDATE MANUALLY.		SHEET 2 OF 2	DRAWING NO. 28-91027	SIZE C
---	--	-----------------	-------------------------	-----------