

THIS DOCUMENT IS THE PROPERTY OF KEYSTONE ELECTRONICS CORP. AND SHALL NOT BE REPRODUCED, DISTRIBUTED OR USED AS A BASIS FOR MANUFACTURE WITHOUT PRIOR WRITTEN PERMISSION FROM KEYSTONE ELECTRONICS CORP.

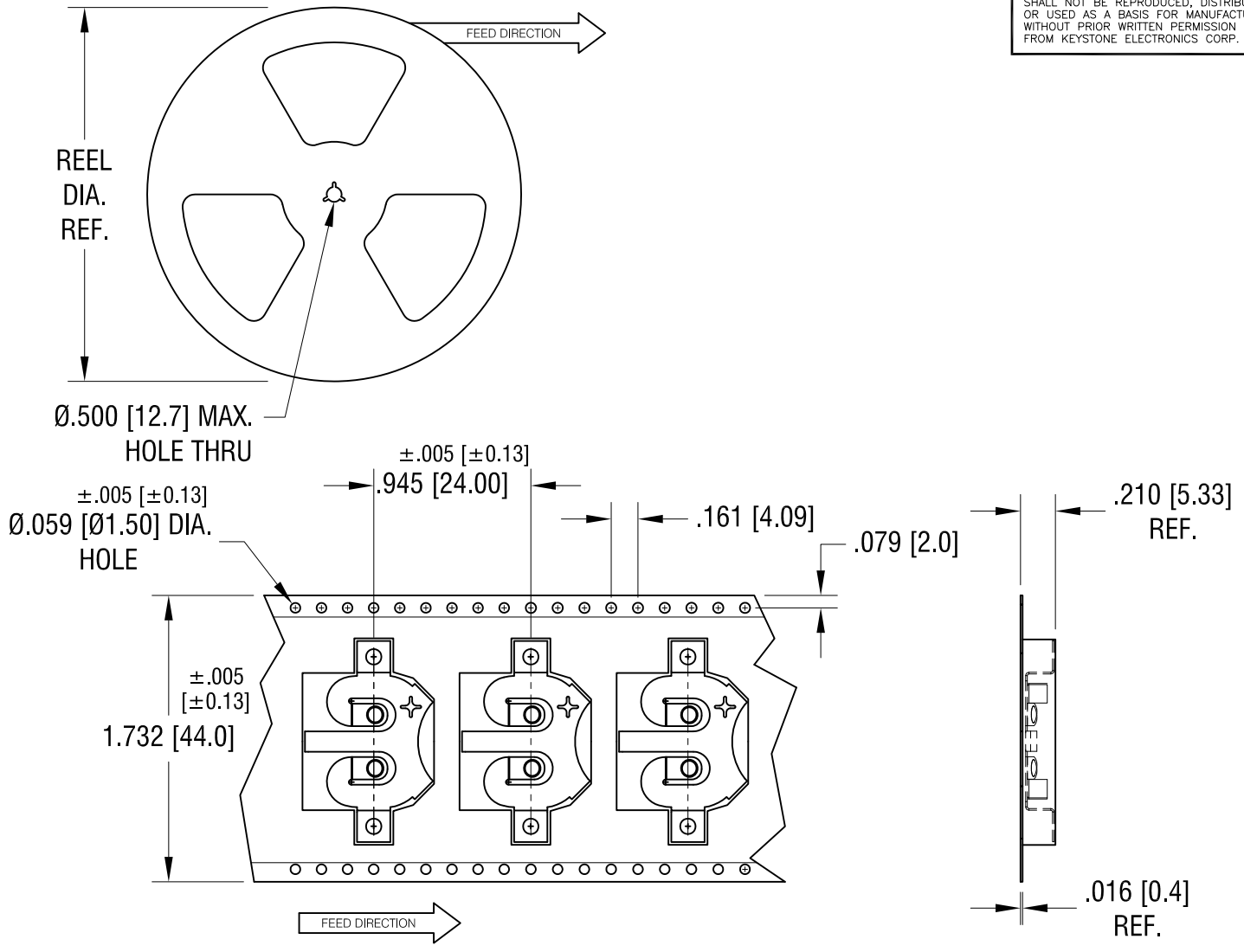

NOTES:

TAPE AND REEL SPECIFICATIONS:

1. TAPE:  
MAT'L - ALL CONDUCTIVE POLYSTYRENE CARRIER  
ANSI/EIA-481 STANDARD
2. REEL:  
13.0 [330.2] DIA. 500 PIECES OF  
PART NO. 2898 PER REEL.

|  |                 |                           |         |
|--|-----------------|---------------------------|---------|
| <b>KEYSTONE ELECTRONICS CORP.</b>                              |                 |                           |         |
| www.keyelco.com • NEW HYDE PARK, NY 11040 • Tel (516) 328-7500 |                 |                           |         |
| PART NAME  |                 | SM COIN CELL CLIP ON TAPE |         |
| MATERIAL   |                 | AS NOTED                  |         |
| FINISH   | AS NOTED        | DRN BY                    | NT      |
|  |                 | APP'D                     | LN      |
|  |                 | DATE                      | 9.19.18 |
|  |                 | SCALE                     | X       |
| TOLERANCES   | INCH [MM]       | CODE                      | DWG NO. |
| DECIMAL  | ± .015 [± 0.38] | C                         | 2898TR  |
| ANGULAR  | ± 1°            |                           |         |
| UNLESS OTHERWISE SPECIFIED                                     |                 |                           |         |

|      |             |      |
|------|-------------|------|
| DATE | DESCRIPTION | REV. |
|      |             |      |