

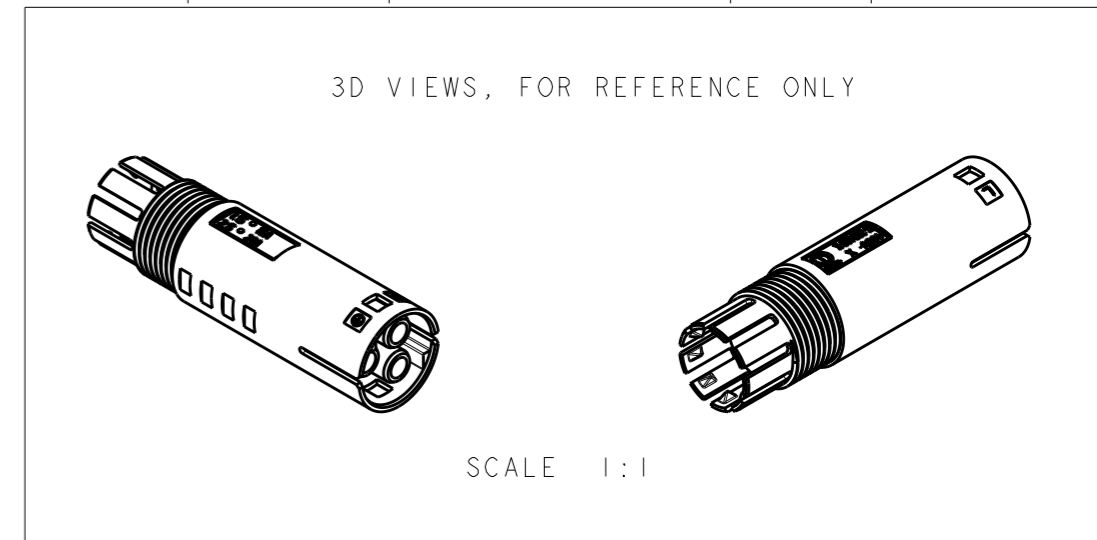
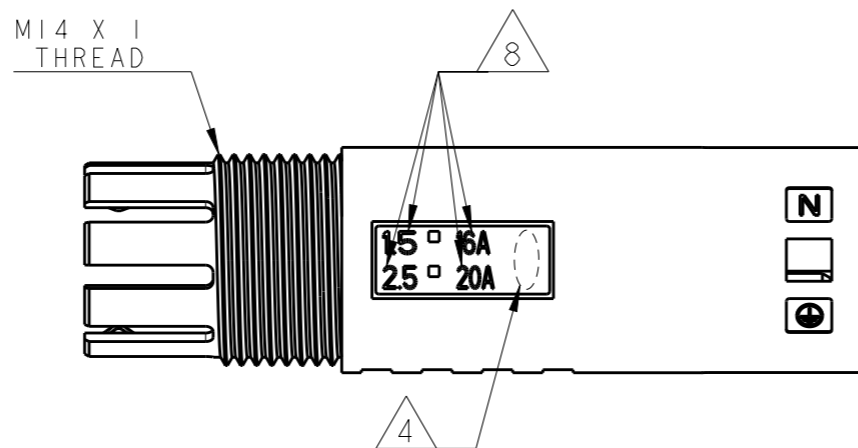
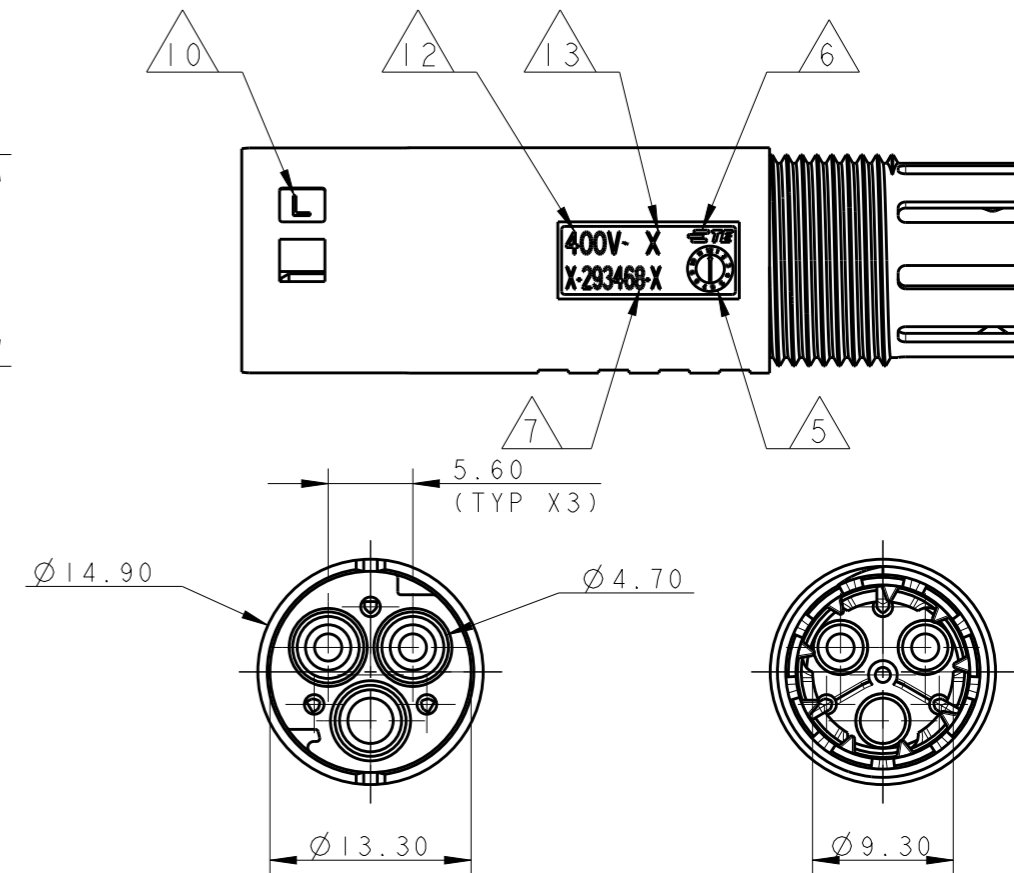
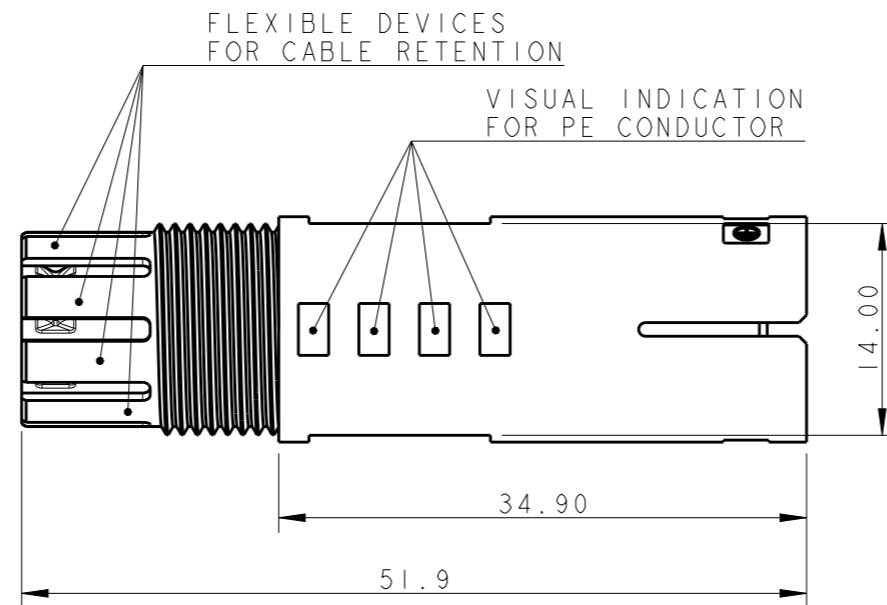

THIS DRAWING IS UNPUBLISHED. RELEASED FOR PUBLICATION 2010  
 © COPYRIGHT 2010 Tyco Electronics AMP GmbH ALL RIGHTS RESERVED.

LOC	DIST	REVISIONS					
		P	LTR	DESCRIPTION	DATE	DWN	APVD
1	-		G1	REVISED MARKINGS	01NOV2012	MZ	JC
			G2	PARTS -2, -3, 1-2, 1-3 RELEASED FOR PRODUCTION	26JUN2013	KR	JC
			G3	REVISED PART NUMBERS	21JUL2017	SK	ZM
			G4	ECR-18-006945	20SEP2018	SR	MZ

NOTES:

- 1 MATERIAL: POLYAMIDE GLASS FILLED COLOUR NATURAL
- 2 MATERIAL: POLYAMIDE GLASS FILLED COLOUR BLACK
- 3) PACKAGING: SEE TE PACKAGING SPECIFICATION 107-20294
- 4 AREA FOR AGENCY APPROVAL LOGO
- 5 DATE CODE
- 6 TE LOGO
- 7 TE PART NUMBER
- 8 CONDUCTOR SIZE AND CURRENT RATING
- 9 N CODE
- 10 L CODE
- 11 PE CODE
- 12 RATED VOLTAGE
- 13 CAVITY MOULD NUMBER
- 14 PART NOT YET TOOLED AND RELEASED FOR PRODUCTION
- 15) FOR CABLE TYPE AND CABLE RANGE REFER TO CUSTOMER DRAWING 293607



THIS DRAWING IS A CONTROLLED DOCUMENT.		DWN M. ZUCCA 21OCT2009	 TE Connectivity	
DIMENSIONS: mm		CHK M. ZUCCA 21OCT2009		
TOLERANCES UNLESS OTHERWISE SPECIFIED:		APVD G. TURCO 21OCT2009	NAME SOCKET HOUSING FREE HANGING NECTOR* M-LINE 3 POSITIONS UNSEALED VERSION	
0 PLC ±-		PRODUCT SPEC 108-20304	SIZE A300779	
1 PLC ±0.3		APPLICATION SPEC 114-20152	CAGE CODE C-293468	
2 PLC ±0.20		WEIGHT ~4.6 g	DRAWING NO	
3 PLC ±-		Customer Drawing	RESTRICTED TO	
4 PLC ±-			SCALE 2:1 SHEET 1 OF 2 REV G4	
ANGLES ±3°				
FINISH -				
MATERIAL SEE NOTES				

THIS DRAWING IS UNPUBLISHED. RELEASED FOR PUBLICATION 2010  
 © COPYRIGHT 2010 Tyco Electronics AMP GmbH ALL RIGHTS RESERVED.

LOC	DIST	REVISIONS					
		P	LTR	DESCRIPTION	DATE	DWN	APVD
1	-		-	SEE SHEET 1	-	-	-

POLARIZATION TYPES	
TYPE "A"	TYPE "B"
P/Ns: 0-293468-1, 1-293468-1	P/Ns: 0-293468-2, 1-293468-2
TYPE "C"	TYPE "D"
P/Ns: 0-293468-3, 1-293468-3	P/Ns: <del>0-293468-4,</del> <del>1-293468-4</del>

TABLE 1						
OBSOLETE		D	BLACK	SOCKET HOUSING FREE HANGING VERSION NECTOR* M-LINE	F	<del>1-293468-4</del>
		C	BLACK	SOCKET HOUSING FREE HANGING VERSION NECTOR* M-LINE	G	1-293468-3
		B	BLACK	SOCKET HOUSING FREE HANGING VERSION NECTOR* M-LINE	G	1-293468-2
		A	BLACK	SOCKET HOUSING FREE HANGING VERSION NECTOR* M-LINE	G	1-293468-1
OBSOLETE		D	NATURAL	SOCKET HOUSING FREE HANGING VERSION NECTOR* M-LINE	F	<del>0-293468-4</del>
		C	NATURAL	SOCKET HOUSING FREE HANGING VERSION NECTOR* M-LINE	G	0-293468-3
		B	NATURAL	SOCKET HOUSING FREE HANGING VERSION NECTOR* M-LINE	G	0-293468-2
		A	NATURAL	SOCKET HOUSING FREE HANGING VERSION NECTOR* M-LINE	G	0-293468-1
NOTE	POL. KEYING	COLOUR	DESCRIPTION	REV.	PART NUMBER	

THIS DRAWING IS A CONTROLLED DOCUMENT.		DWN M. ZUCCA 21OCT2009	TE Connectivity		
DIMENSIONS: mm		CHK M. ZUCCA 21OCT2009			
TOLERANCES UNLESS OTHERWISE SPECIFIED:		APVD G. TURCO 21OCT2009	NAME SOCKET HOUSING FREE HANGING NECTOR* M-LINE 3 POSITIONS UNSEALED VERSION		
0 PLC ± 1 PLC ±0.3 2 PLC ±0.20 3 PLC ± 4 PLC ± ANGLES ±3°		PRODUCT SPEC 108-20304	SIZE A3	CAGE CODE 00779	DRAWING NO C-293468
MATERIAL SEE NOTES		APPLICATION SPEC 114-20152	RESTRICTED TO		
		WEIGHT ~4.6 g	SCALE 2:1 SHEET 2 OF 2 REV G4		
		Customer Drawing			