Pilot 10/20/30

Programme range

Enclosure type	Order No.	Encl. dimensions incl. handle	Front panel dimensions	Mounting depth
		W x L x H (mm)	W x H (mm)	(mm)
Pilot 10	29.40 02 00	70 x 93 x 190	61 x 59	67
Pilot 20	29.30 01 00	115 x 93 x 200	106 x 69	67
Pilot 30	29.50 01 00	164 x 116 x 295	70 x 280	71

Accessories

Mounting plate Pilot 20	29.31 00 00
Wall holder (2 pcs with screws)	29.60 01 00
Cable gland M 20 x 1,5	08.10 01 20
Push button and switches see page 53 - 58	on request



Electromechanical components
On request, we can supply equipment fitted with electro-mechanical components such as emergency stop button, acknowledge keys, hand wheel, switches, display

Dimensions



Type	Order No.	Weight (kg)
Pilot 10	29.40 02 00	0.380
Pilot 20	29.30 01 00	0.500

Pilot 10

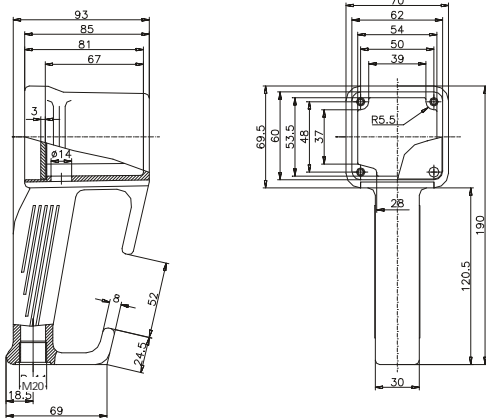

Pilot 20

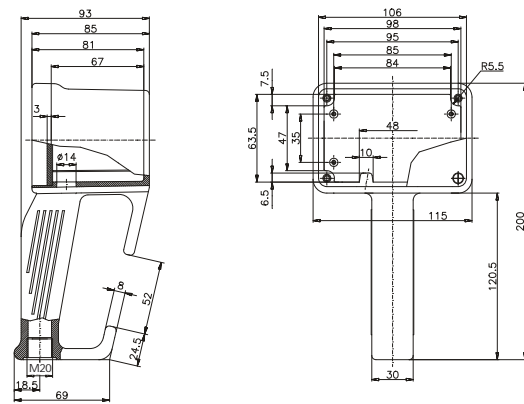

Type	Order No.	Weight (kg)
Pilot 30	29.50 01 00	2.200

