

# PRODUCT DATA DRAWING

REVISION HISTORY			
REV	DESCRIPTION	DATE	APPROVED
-	DCN 40055	09/13	STW

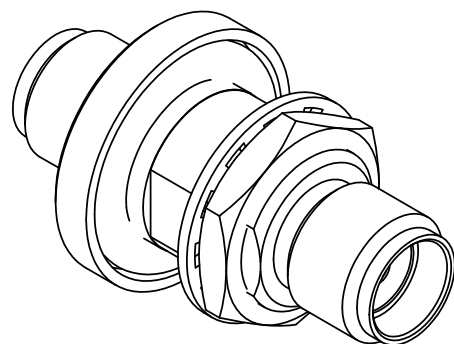

Ø .500 [ 12.70 ]

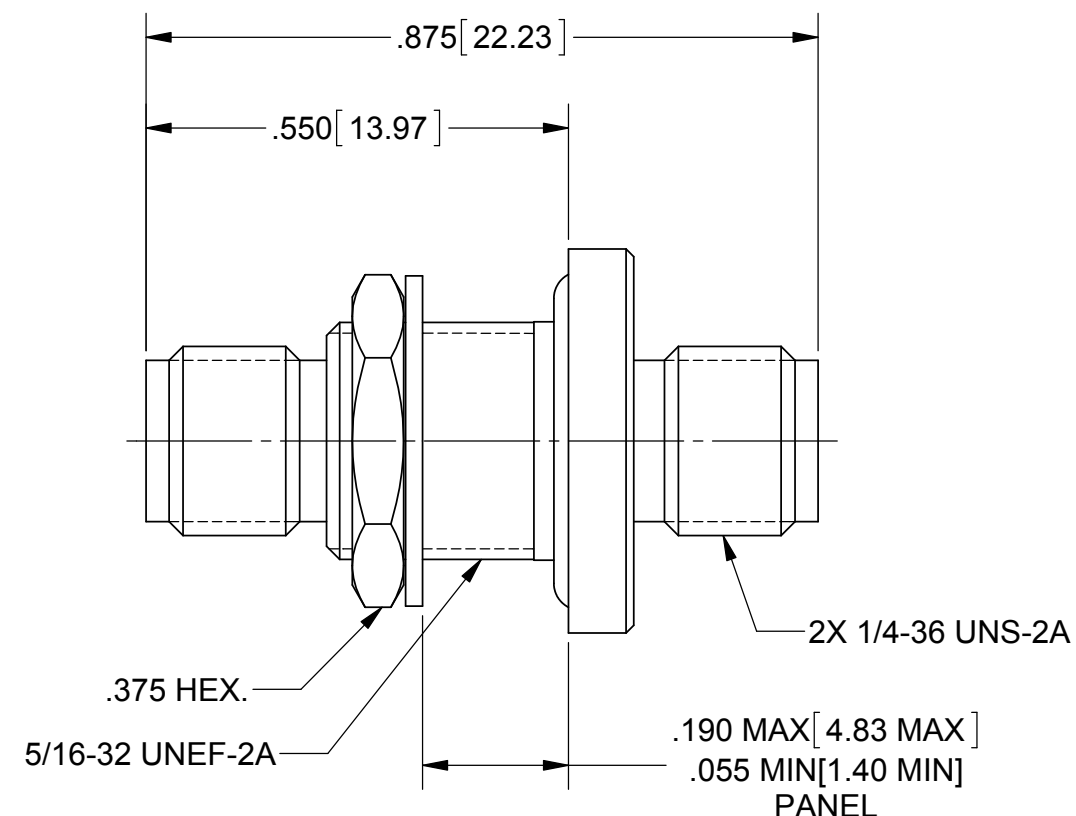
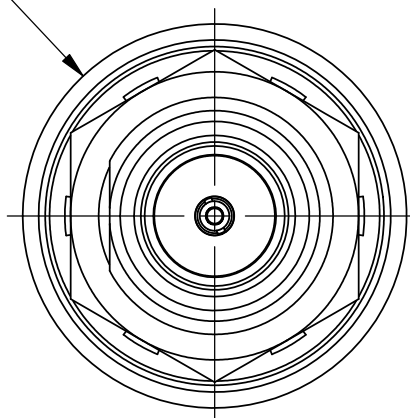

**MATERIAL:**

- BODY & HEX. NUT: STAINLESS STEEL PER AMS-5640, ALLOY UNS S30300, TYPE 1
- CONTACT: BERYLLIUM COPPER PER ASTM B196, ALLOY No. UNS C17300, TD04
- INSULATOR: PTFE PER ASTM D1710, TYPE I, GRADE 1, CLASS B
- O-RING: SILICONE RUBBER PER A-A-59588, CLASS 2B, GRADE 50/60
- LOCKWASHER: 300 SERIES STAINLESS STEEL
- GLASS: EN1 OR EQUIVALENT
- PIN: KOVAR

**FINISH:**

- BODY & CONTACT: GOLD PER ASTM B488, TYPE II, CODE C, CLASS 0.76, OVER NICKEL PER AMS-QQ-N-290, CLASS 1, .00005" MIN.
- HEX NUT & LOCKWASHER: GOLD PER ASTM B488, TYPE I, CODE C, CLASS 0.50, OVER NICKEL PER AMS-QQ-N-290, CLASS 1, .00005" MIN.
- PIN: NICKEL PER AMS-QQ-N-290, CLASS 1

**PERFORMANCE:**

- IMPEDANCE: 50 OHMS
- FREQ. RANGE: DC TO 18.0 GHz
- VSWR: 1.05 + .010F (F IN GHz)
- INSERTION LOSS: .05 X SQRT(F(F IN GHz))
- LEAK RATE: SHALL NOT EXCEED 1 X 10<sup>-8</sup> CC/SEC

**RECOMMENDED MOUNTING HOLE**

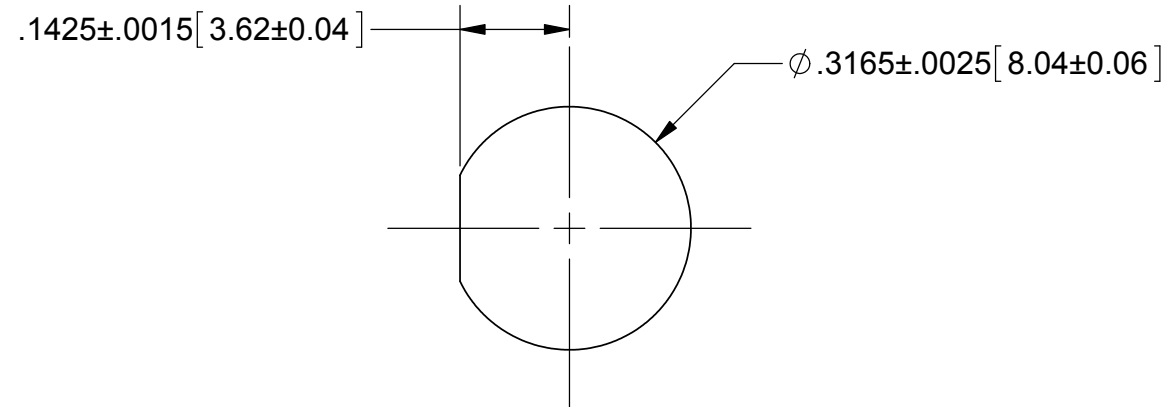

MATERIAL: SEE NOTES	DIMENSIONS ARE IN INCHES TOLERANCES: FRACTIONAL: ±1/64 ANGULAR: X° ±1'0" X'X' ±15'	UNLESS OTHERWISE SPECIFIED 1) ALL DIMENSIONS ARE IN INCHES (MILLIMETERS) 2) ALL DIMENSIONS ARE AFTER PLATING. 3) BREAK CORNERS & EDGES .005 R. MAX. 4) CHAM. 1ST & LAST THREADS. 5) SURFACE ROUGHNESS 63-MIL-STD-10. 6) DIA.'S ON COMMON CENTERS TO BE CONCENTRIC WITHIN .005 T.I.R. 7) REMOVE ALL BURRS	<b>SV Microwave, Inc.</b> 2400 Centrepark West Drive, Suite 100 West Palm Beach, FL 33409
FINISH: SEE NOTES	DECIMAL: X ±.030 .XX ±.010 .XXX ±.005	INTERPRET DIMENSIONS AND TOLERANCES PER ASME Y14.5M - 1994	TITLE: SMA JACK TO JACK BULKHEAD ADAPTER HERMETIC SEAL
SURFACE AREA: N/A	THIRD ANGLE PROJECTION	DRAWN: FSG 09/16/13	SIZE B CAGE CODE 95077 DWG. NO. 2991-6002
PROPRIETARY THE INFORMATION CONTAINED IN THIS DRAWING IS THE SOLE PROPERTY OF SV MICROWAVE, INC. ANY REPRODUCTION IN PART OR AS A WHOLE WITHOUT THE WRITTEN PERMISSION OF SV MICROWAVE, INC IS PROHIBITED.		CHECKED: STW 09/16/13	SCALE: 4:1
		APPROVED: STW 09/16/13	SHEET 1 OF 1