

**TO - 18 NPN SILICON PLANAR SWITCHING TRANSISTORS**

**Switching And Linear Application DC And VHF Amplifier Applications**

**ABSOLUTE MAXIMUM RATINGS**

DESCRIPTION	SYMBOL	2N2222A	UNIT
Collector -Emitter Voltage	VCEO	40	V
Collector -Base Voltage	VCBO	75	V
Emitter -Base Voltage	VEBO	6.0	V
Collector Current Continuous	IC	800	mA
Power Dissipation @ Ta=25 degC	PD	500	mW
Derate Above 25deg C		2.28	mW/deg C
@ Tc=25 degC	PD	1.2	W
Derate Above 25deg C		6.85	mW/deg C
Operating And Storage Junction Temperature Range	Tj, Tstg	-65 to +200	deg C

**ELECTRICAL CHARACTERISTICS (Ta=25 deg C Unless Otherwise Specified)**

DESCRIPTION	SYMBOL	TEST CONDITION	VALUE		UNIT
			MIN	MAX	
Collector -Emitter Voltage	VCEO	IC=10mA, IB=0	40	-	V
Collector -Base Voltage	VCBO	IC=10uA, IE=0	75	-	V
Emitter-Base Voltage	VEBO	IE=10uA, IC=0	6.0	-	V
Collector-Cut off Current	ICBO	VCB=60V, IE=0	-	10	nA
		Ta=150 deg C			
		VCB=60V, IE=0	-	10	uA
Emitter-Cut off Current	ICEX	VCE=60V, VEB=3V	-	10	nA
	IEBO	VEB=3V, IC=0	-	10	nA
Base-Cut off Current	IBL	VCE=60V, VEB=3V	-	20	nA
Collector Emitter Saturation Voltage	VCE(Sat)*	IC=150mA, IB=15mA	-	0.3	V
		IC=500mA, IB=50mA		1.0	V
Base Emitter Saturation Voltage	VBE(Sat) *	IC=150mA, IB=15mA	-	0.6-1.2	V
		IC=500mA, IB=50mA	-	2.0	V

**ELECTRICAL CHARACTERISTICS (Ta=25 deg C Unless Otherwise Specified)**
**2N2222A**

DESCRIPTION	SYMBOL	TEST CONDITION		UNIT	
DC Current Gain	hFE	IC=0.1mA, VCE=10V	>35		
		IC=1mA, VCE=10V	>50		
		IC=10mA, VCE=10V	>75		
			Ta=55 deg C		
			IC=10mA, VCE=10V	>35	
			IC=150mA, VCE=10V	100-300	
			IC=150mA, VCE=1V	>50	
		IC=500mA, VCE=10V	>40		
<b><u>DYNAMIC CHARACTERISTICS</u></b>					
Small Signal Current Gain	hfe	ALL f=1kHz IC=1mA, VCE=10V	50-300		
		IC=10mA, VCE=10V	75-375		
Input Impedance	hie	IC=1mA, VCE=10V	2.0-8.0	kohms	
		IC=10mA, VCE=10V	0.25-1.25		
Voltage Feedback Ratio	hre	IC=1mA, VCE=10V	<8.0	x10-4	
		IC=10mA, VCE=10V	<4.0		
Out put Admittance	hoe	IC=1mA, VCE=10V	5.0-35	umhos	
		IC=10mA, VCE=10V	25-200		
Collector Base Time Constant	rb'Cc	IE=20mA, VCB=20V f=31.8MHz	<150	ps	
Real Part Common-Emitter High Frequency Input Impedance	Re(hie)	IC=20mA, VCE=20V f=300MHz	<60	ohms	
Noise Figure	NF	IC=100uA, VCE=10V Rs=1kohms, f=1kHz	- <4.0	dB	
<b><u>DYNAMIC CHARACTERISTICS</u></b>					
Transistors Frequency	ft	IC=20mA, VCE=20V f=100MHz	>300	MHz	
Out-Put Capacitance	Cob	VCB=10V, IE=0 f=100kHz	<8.0	pF	
Input Capacitance	Cib	VEB=0.5V, IC=0 f=100kHz	<25	pF	
<b>SWITCHING Time</b>					
Delay time	td	IC=150mA, IB1=15mA	<10	ns	
Rise time	tr	VCC=30V, VBE=0.5V -	<25	ns	
Storage time	ts	IC=150mA, IB1=	<225	ns	
Fall time	tf	IB2=15mA, VCC=30V -	<60	ns	

**\*Pulse Condition: Pulse Width=300us, Duty Cycle=2%**

### TO-18 Metal Can Package

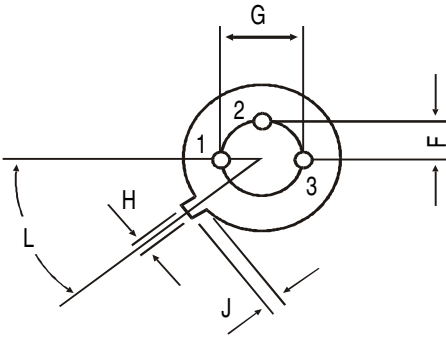
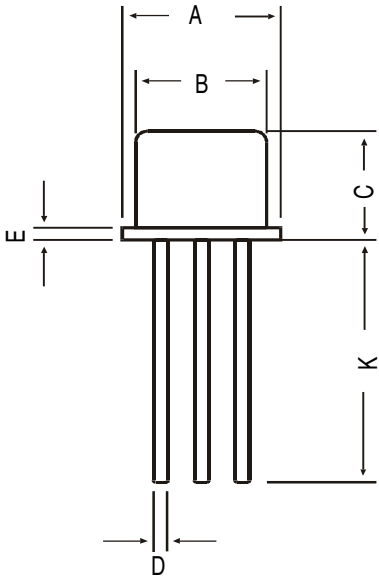

All dimensions in mm.

DIM	MIN	MAX
A	5.24	5.84
B	4.52	4.97
C	4.31	5.33
D	0.40	0.53
E	—	0.76
F	—	1.27
G	—	2.97
H	0.91	1.17
J	0.71	1.21
K	12.70	—
L	45 DEG	

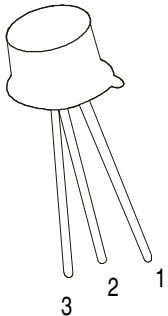

**PIN CONFIGURATION**  
 1. EMITTER  
 2. BASE  
 3. COLLECTOR