

Features

- Small Package
- Halogen Free. "Green" Device (Note 1)
- Moisture Sensitivity Level 1
- Epoxy Meets UL 94 V-0 Flammability Rating
- Lead Free Finish/RoHS Compliant ("P" Suffix Designates RoHS Compliant. See Ordering Information)

Maximum Ratings @ 25°C Unless Otherwise Specified

- Operating Junction Temperature Range: -55°C to +150°C
- Storage Temperature Range: -55°C to +150°C
- Thermal Resistance: 625°C/W Junction to Ambient

Parameter	Symbol	Rating	Unit
Collector-Base Voltage	V_{CBO}	-60	V
Collector-Emitter Voltage	V_{CEO}	-50	V
Emitter-Base Voltage	V_{EBO}	-6	V
Collector Current	I_C	-150	mA
Power Dissipation	P_D	200	mW

Note: 1. Halogen free "Green" products are defined as those which contain <900ppm bromine, <900ppm chlorine (<1500ppm total Br + Cl) and <1000ppm antimony compounds.

Internal Structure

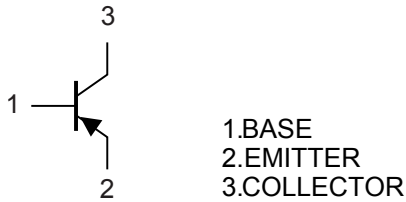

PNP Silicon Epitaxial Transistors

SOT-23

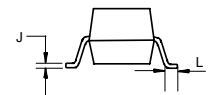
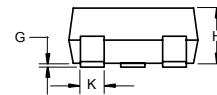
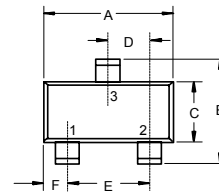

DIM	DIMENSIONS				NOTE
	INCHES		MM		
	MIN	MAX	MIN	MAX	
A	0.110	0.120	2.80	3.04	
B	0.083	0.104	2.10	2.64	
C	0.047	0.055	1.20	1.40	
D	0.034	0.041	0.85	1.05	
E	0.067	0.083	1.70	2.10	
F	0.018	0.024	0.45	0.60	
G	0.0004	0.006	0.01	0.15	
H	0.035	0.043	0.90	1.10	
J	0.003	0.007	0.08	0.18	
K	0.012	0.020	0.30	0.51	
L	0.007	0.020	0.20	0.50	

Suggested Solder Pad Layout

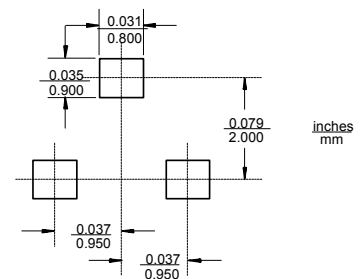

Electrical Characteristics @ T_A=25°C Unless Otherwise Specified

Parameter	Symbol	Min	Typ	Max	Units	Conditions
Collector-Base Breakdown Voltage	V _{(BR)CBO}	-60			V	I _C =-50μA, I _E =0
Collector-Emitter Breakdown Voltage	V _{(BR)CEO}	-50			V	I _C =-1mA, I _B =0
Emitter-Base Breakdown Voltage	V _{(BR)EBO}	-6			V	I _E =-50μA, I _C =0
Collector-Base Cutoff Current	I _{CBO}			-0.1	μA	V _{CB} =-60V, I _E =0
Emitter-Base Cutoff Current	I _{EBO}			-0.1	μA	V _{EB} =-6V, I _C =0
DC Current Gain	h _{FE}	120		560		V _{CE} =-6V, I _C =-1mA
Collector-Emitter Saturation Voltage	V _{CE(sat)}			-0.5	V	I _C =-50mA, I _B =-5mA
Transition Frequency	f _T	120			MHz	V _{CE} =-12V, I _C =-2mA, f=30MHz

Classification of h_{FE}

Rank	Q	R	S
Range	120-270	180-390	270-560
Marking	FQ	FR	FS

Curve Characteristics

Fig. 1 - Static Characteristics

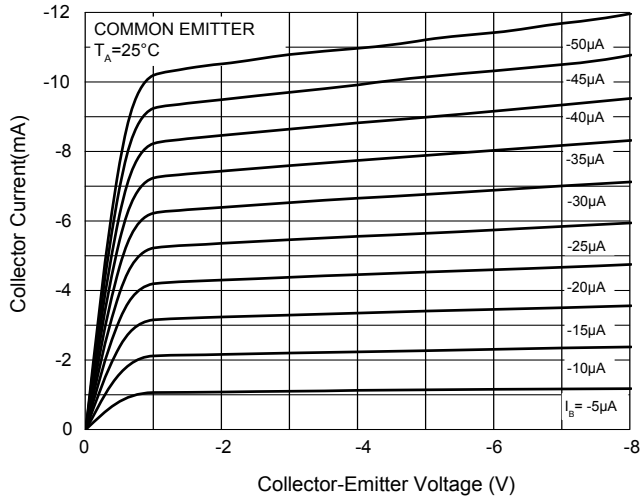

Fig. 2 - DC Current Gain Characteristics

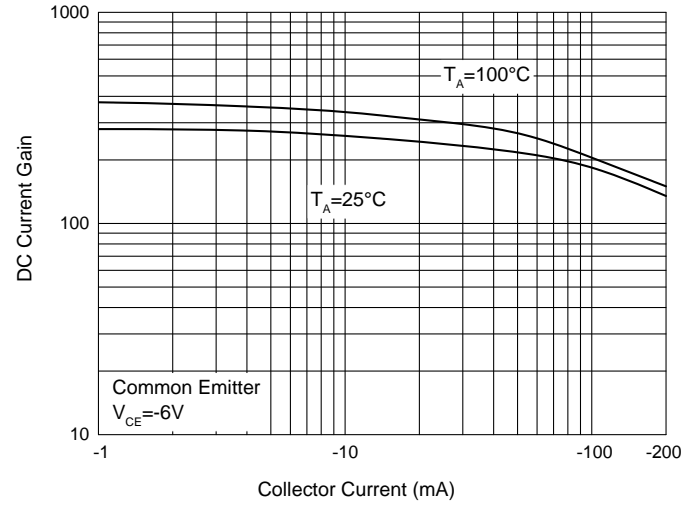

Fig. 3 - Collector-Emitter Saturation Voltage Characteristics

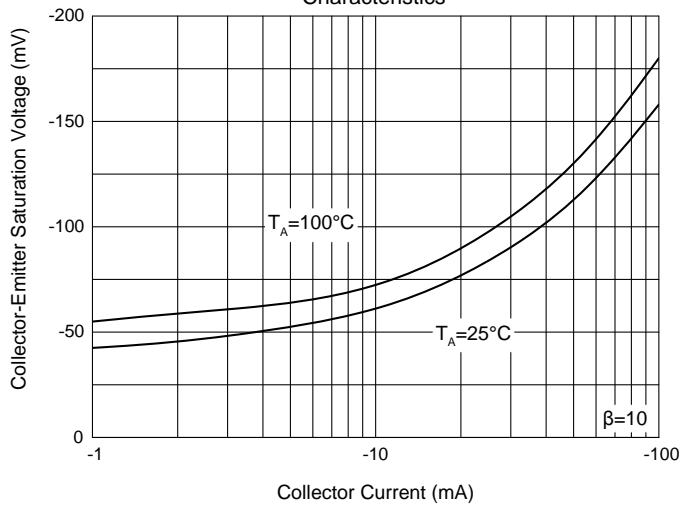

Fig. 4 - Base-Emitter Saturation Voltage Characteristics

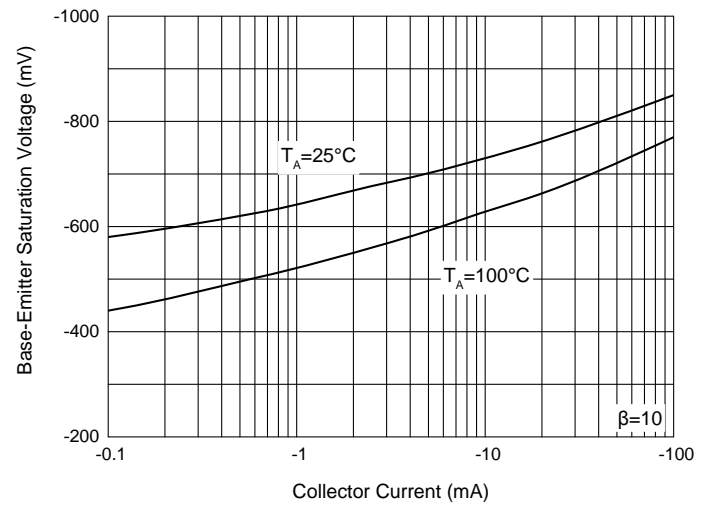

Fig. 5 - Base-Emitter Voltage Characteristics

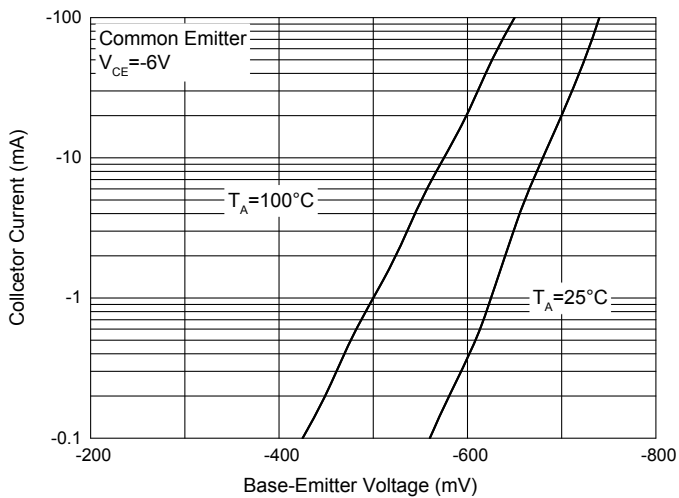

Fig. 6 - Power Derating Curve

