

Low voltage fast-switching PNP power bipolar transistor

Features

- Very low collector-emitter saturation voltage
- High current gain characteristic
- Fast switching speed
- Surface mounting device in medium power SOT-223 package

Applications

- Emergency lighting
- LED
- CCFL drivers (back lighting)
- Voltage regulation
- Relay driver

Description

The device is a PNP transistor manufactured using new "PB-HCD" (Power Bipolar High Current Density) technology. The resulting transistor shows exceptional high gain performances coupled with very low saturation voltage.

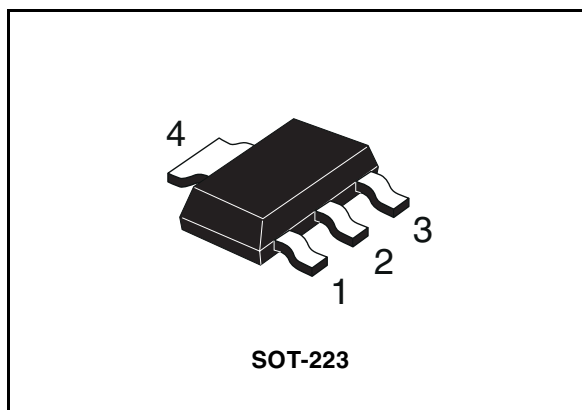

Figure 1. Internal schematic diagram

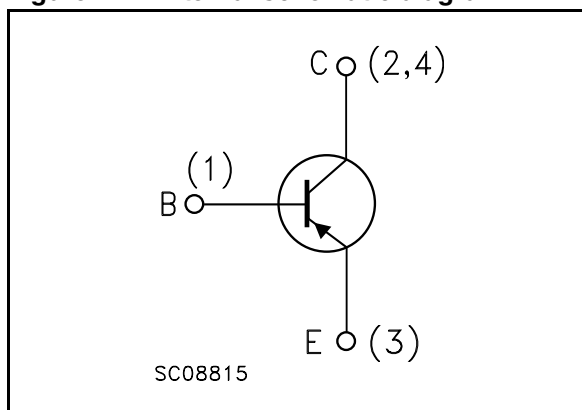

Table 1. Device summary

Order code	Marking	Package	Packaging
2STN2540	N2540	SOT-223	Tape and reel

1 Electrical ratings

Table 2. Absolute maximum rating

Symbol	Parameter	Value	Unit
V_{CBO}	Collector-base voltage ($I_E = 0$)	-40	V
V_{CEO}	Collector-emitter voltage ($I_B = 0$)	-40	V
V_{EBO}	Emitter-base voltage ($I_C = 0$)	-6	V
I_C	Collector current	-5	A
I_{CM}	Collector peak current ($t_P < 5\text{ms}$)	-10	A
I_{BM}	Base peak current ($t_P < 5\text{ms}$)	-2	A
P_{tot}	Total dissipation at $T_{amb} = 25\text{ °C}$	1.6	W
T_{stg}	Storage temperature	-65 to 150	°C
T_J	Max. operating junction temperature	150	°C

Table 3. Thermal data

Symbol	Parameter	Value	Unit
$R_{thj-amb}^{(1)}$	Thermal resistance junction-amb max	78	°C/W

1. Device mounted on PCB area of 1cm^2

2 Electrical characteristics

($T_{\text{case}} = 25\text{ °C}$ unless otherwise specified)

Table 4. Electrical characteristics

Symbol	Parameter	Test conditions	Min.	Typ.	Max.	Unit
I_{CBO}	Collector cut-off current ($I_{\text{E}} = 0$)	$V_{\text{CB}} = -30\text{ V}$			-0.1	μA
I_{EBO}	Emitter cut-off current ($I_{\text{C}} = 0$)	$V_{\text{EB}} = -5\text{ V}$			-0.1	μA
$V_{\text{CE(sat)}}^{(1)}$	Collector-emitter saturation voltage	$I_{\text{C}} = -0.5\text{ A}$ $I_{\text{B}} = -5\text{ mA}$		-80	-120	mV
		$I_{\text{C}} = -1\text{ A}$ $I_{\text{B}} = -10\text{ mA}$		-120	-180	mV
		$I_{\text{C}} = -2\text{ A}$ $I_{\text{B}} = -200\text{ mA}$		-140	-200	mV
		$I_{\text{C}} = -5\text{ A}$ $I_{\text{B}} = -500\text{ mA}$		-350	-450	mV
$V_{\text{BE(sat)}}^{(1)}$	Base-emitter saturation voltage	$I_{\text{C}} = -5\text{ A}$ $I_{\text{B}} = -500\text{ mA}$			-1.3	V
$V_{\text{BE(on)}}^{(1)}$	Base-emitter on voltage	$V_{\text{CE}} = -2\text{ V}$ $I_{\text{C}} = -2\text{ A}$			-1.25	V
$h_{\text{FE}}^{(1)}$	DC current gain	$I_{\text{C}} = -0.5\text{ A}$ $V_{\text{CE}} = -2\text{ V}$	250			
		$I_{\text{C}} = -1\text{ A}$ $V_{\text{CE}} = -2\text{ V}$	200			
		$I_{\text{C}} = -2\text{ A}$ $V_{\text{CE}} = -2\text{ V}$	150			
		$I_{\text{C}} = -5\text{ A}$ $V_{\text{CE}} = -2\text{ V}$	50			
C_{CBO}	Collector-base capacitance	$I_{\text{E}} = 0$ $V_{\text{CB}} = -10\text{ V}$ $f = 1\text{ MHz}$		80		pF
t_{on} t_{s} t_{f}	Resistive load Turn-on time	$I_{\text{C}} = -1\text{ A}$ $V_{\text{CC}} = -10\text{ V}$ $-I_{\text{B1}} = I_{\text{B2}} = -0.1\text{ A}$		75		ns
	Storage time	$T_{\text{p}} = 30\text{ }\mu\text{s}$		426		ns
	Fall time			62		ns

1. Pulsed duration = 300 μs , duty cycle $\leq 5\%$

2.1 Electrical characteristics (curves)

Figure 2. Output characteristics

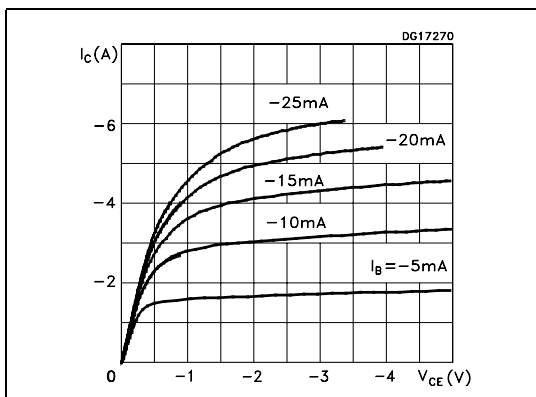

Figure 3. DC current gain

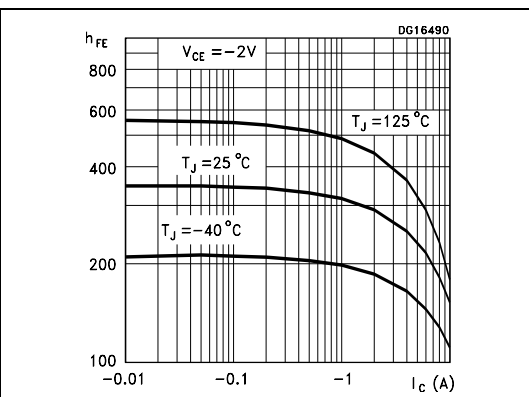

Figure 4. Collector-emitter saturation voltage

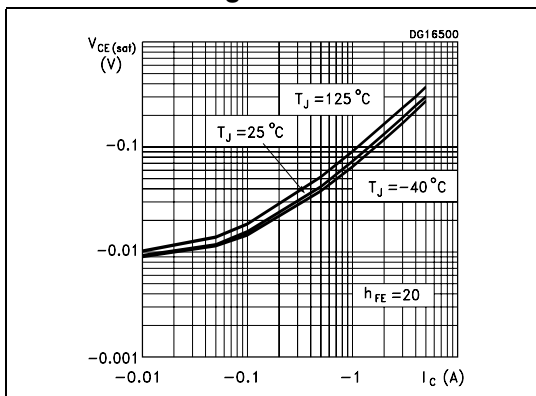

Figure 5. Base-emitter saturation voltage

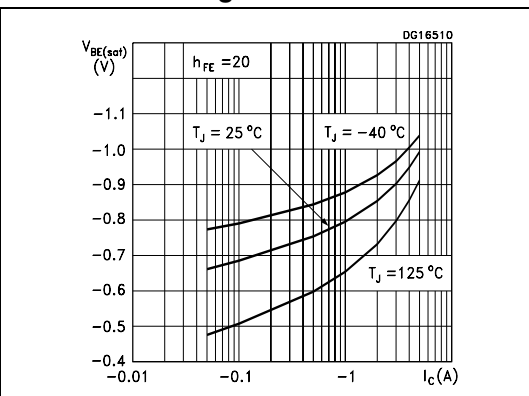

Figure 6. Base-emitter on voltage

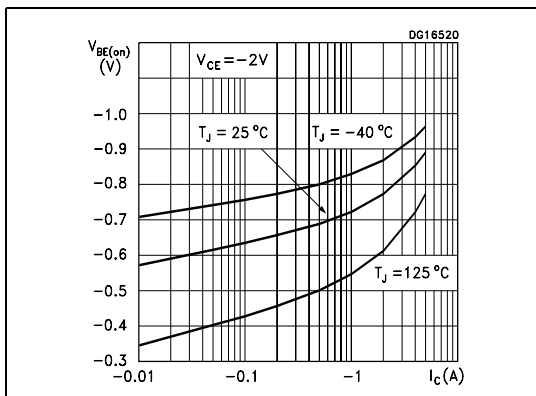

Figure 7. Resistive load switching times

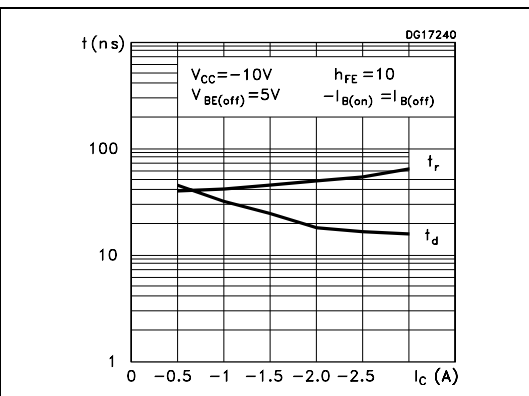

Figure 8. Resistive load switching times

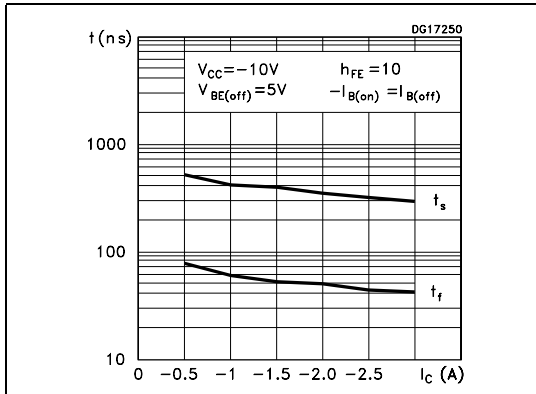
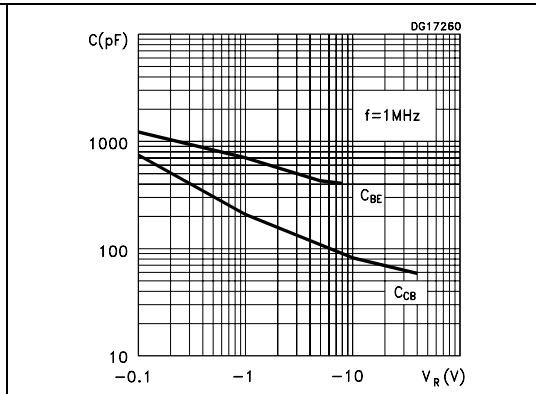
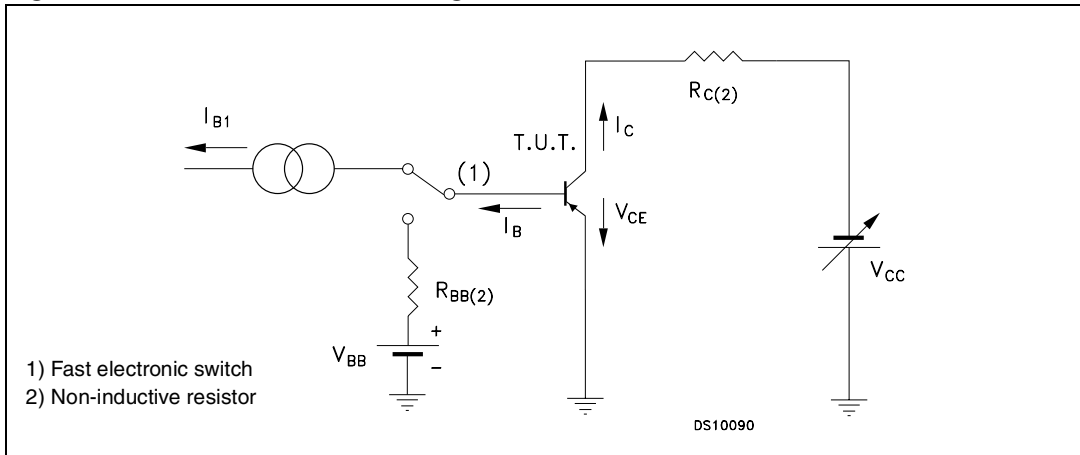

Figure 9. Capacitance



2.2 Test circuit

Figure 10. Resistive load switching test circuit



3 Package mechanical data

In order to meet environmental requirements, ST offers these devices in ECOPACK® packages. These packages have a Lead-free second level interconnect. The category of second level interconnect is marked on the package and on the inner box label, in compliance with JEDEC Standard JESD97. The maximum ratings related to soldering conditions are also marked on the inner box label. ECOPACK is an ST trademark. ECOPACK specifications are available at: www.st.com

SOT-223 mechanical data

DIM.	mm.		
	min.	typ	max.
A			1.80
A1	0.02		0.1
B	0.60	0.70	0.85
B1	2.90	3.00	3.15
c	0.24	0.26	0.35
D	6.30	6.50	6.70
e		2.30	
e1		4.60	
E	3.30	3.50	3.70
H	6.70	7.00	7.30
V			10°

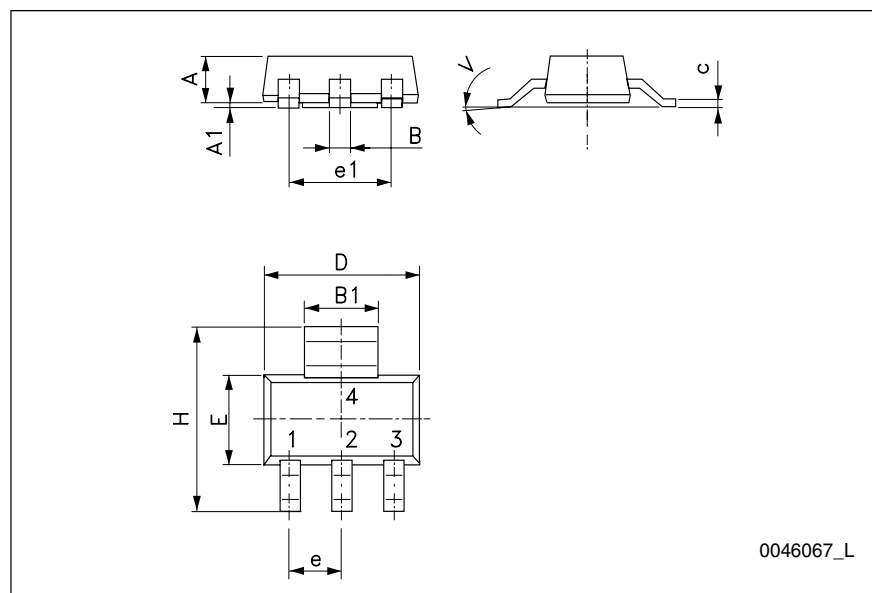

4 Revision history

Table 5. Document revision history

Date	Revision	Changes
23-Oct-2003	1	Initial release
03-Nov-2006	2	Added new graphics: fig.2, fig. 7, fig.8, fig.9.
14-Jan-2008	3	Document status promoted from preliminary data to datasheet.