

Low voltage fast-switching NPN power transistor

Datasheet - production data

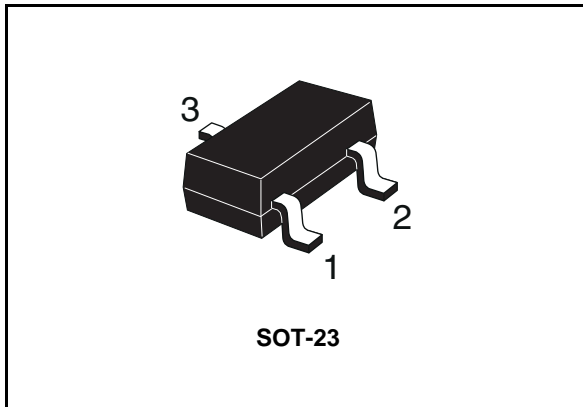
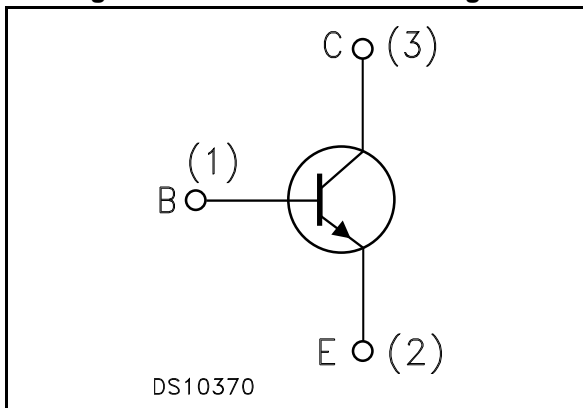

Figure 1. Internal schematic diagram



Features

- Very low collector-emitter saturation voltage
- High current gain characteristic
- Fast switching speed
- Miniature SOT-23 plastic package for surface mounting circuits

Applications

- LED
- Battery charger
- Voltage and relay drive
- Voltage regulation

Description

The 2STR1215 is a NPN transistor manufactured using new "PB-HCD" (Power Bipolar High Current Density) technology. The resulting transistor shows exceptional high gain performances coupled with very low saturation voltage.

Table 1. device summary

Order code	Marking	Package	Packaging
2STR1215	1215	SOT-23	Tape and reel

Contents

- 1 Electrical ratings 3**

- 2 Electrical characteristics 4**
 - 2.1 Electrical characteristics (curves) 5
 - 2.2 Test circuits 6

- 3 Package mechanical data 7**
 - 3.1 SOT-23 package information 7

- 4 Revision history 10**



1 Electrical ratings

Table 2. Absolute maximum rating

Symbol	Parameter	Value	Unit
V_{CBO}	Collector-base voltage ($I_E = 0$)	15	V
V_{CEO}	Collector-emitter voltage ($I_B = 0$)	15	V
V_{EBO}	Emitter-base voltage ($I_C = 0$)	5	V
I_C	Collector current	1.5	A
I_{CM}	Collector peak current ($t_P < 5$ ms)	3	A
P_{tot}	Total dissipation at $T_{amb} = 25$ °C	0.5	W
T_{stg}	Storage temperature range	-65 to 150	°C
T_J	Operating junction temperature range		

Table 3. Thermal data

Symbol	Parameter	Value	Unit
$R_{thj-amb}^{(1)}$	Thermal resistance junction-amb max	250	°C/W

1. Device mounted on PCB area of 1 cm²

2 Electrical characteristics

($T_{\text{case}} = 25^{\circ}\text{C}$ unless otherwise specified)

Table 4. Electrical characteristics

Symbol	Parameter	Test conditions	Min.	Typ.	Max.	Unit
I_{CBO}	Collector cut-off current ($I_{\text{E}} = 0$)	$V_{\text{CB}} = 15 \text{ V}$			0.1	μA
I_{EBO}	Emitter cut-off current ($I_{\text{C}} = 0$)	$V_{\text{EB}} = 4 \text{ V}$			0.1	μA
$V_{(\text{BR})\text{CBO}}$	Collector-base breakdown voltage ($I_{\text{E}} = 0$)	$I_{\text{C}} = 100 \mu\text{A}$	15			V
$V_{(\text{BR})\text{CEO}}^{(1)}$	Collector-emitter breakdown voltage ($I_{\text{B}} = 0$)	$I_{\text{C}} = 10 \text{ mA}$	15			V
$V_{(\text{BR})\text{EBO}}$	Emitter-base breakdown voltage ($I_{\text{C}} = 0$)	$I_{\text{E}} = 100 \mu\text{A}$	5			V
$V_{\text{CE}(\text{sat})}^{(1)}$	Collector-emitter saturation voltage	$I_{\text{C}} = 0.1 \text{ A}$ $I_{\text{B}} = 1 \text{ mA}$			0.15	V
		$I_{\text{C}} = 1 \text{ A}$ $I_{\text{B}} = 100 \text{ mA}$		0.25	0.5	V
		$I_{\text{C}} = 2 \text{ A}$ $I_{\text{B}} = 200 \text{ mA}$		0.4	0.85	V
$V_{\text{BE}(\text{sat})}^{(1)}$	Base-emitter saturation voltage	$I_{\text{C}} = 1 \text{ A}$ $I_{\text{B}} = 100 \text{ mA}$		0.9	1.25	V
$h_{\text{FE}}^{(1)}$	DC current gain	$I_{\text{C}} = 50 \text{ mA}$ $V_{\text{CE}} = 2 \text{ V}$	200			
		$I_{\text{C}} = 0.5 \text{ A}$ $V_{\text{CE}} = 2 \text{ V}$	200	280	560	
		$I_{\text{C}} = 1 \text{ A}$ $V_{\text{CE}} = 2 \text{ V}$	130			
		$I_{\text{C}} = 2 \text{ A}$ $V_{\text{CE}} = 2 \text{ V}$	80			
C_{CBO}	Collector-base capacitance ($I_{\text{E}} = 0$)	$V_{\text{CB}} = 10 \text{ V}$ $f = 1 \text{ MHz}$		16		pF
t_{on}	Turn-on time	Resistive load $I_{\text{C}} = 1.5 \text{ A}$ $V_{\text{CC}} = 10 \text{ V}$		60		ns
t_{off}	Turn-off time	$I_{\text{B1}} = -I_{\text{B2}} = 150 \text{ mA}$		310		ns

1. Pulsed duration = 300 μs , duty cycle $\leq 1.5\%$

2.1 Electrical characteristics (curves)

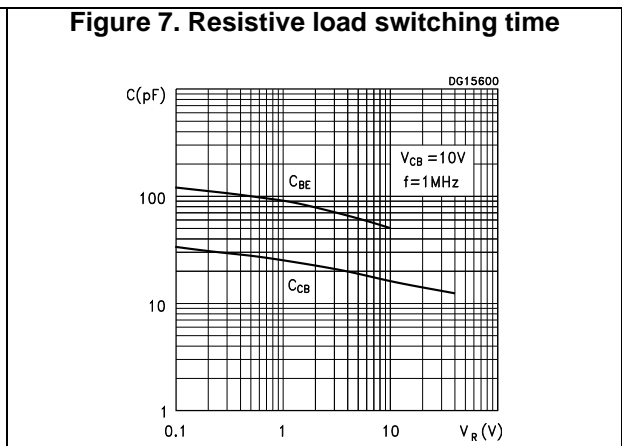
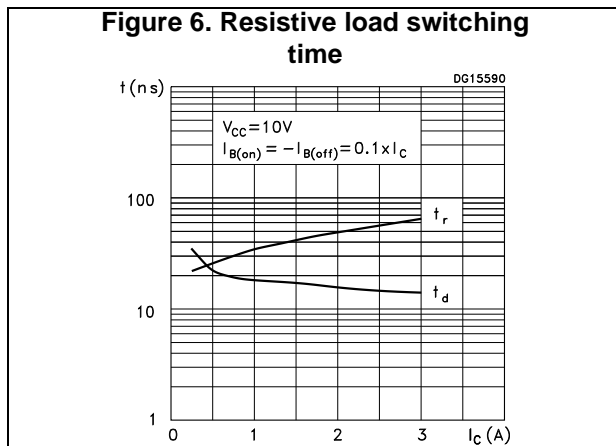
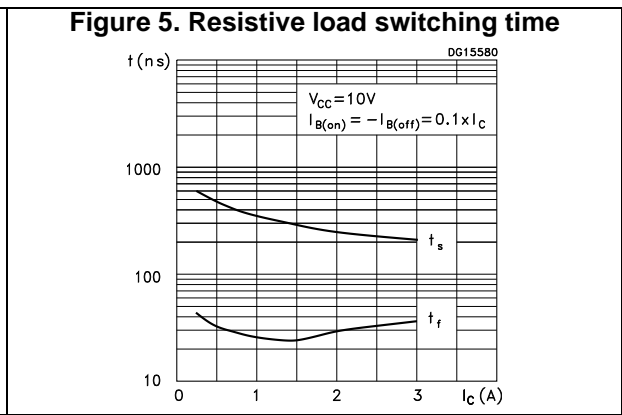
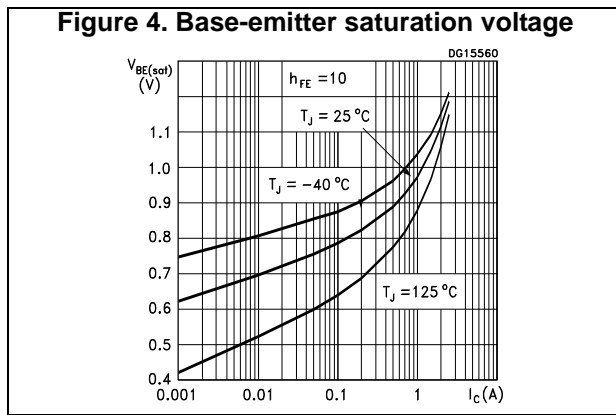
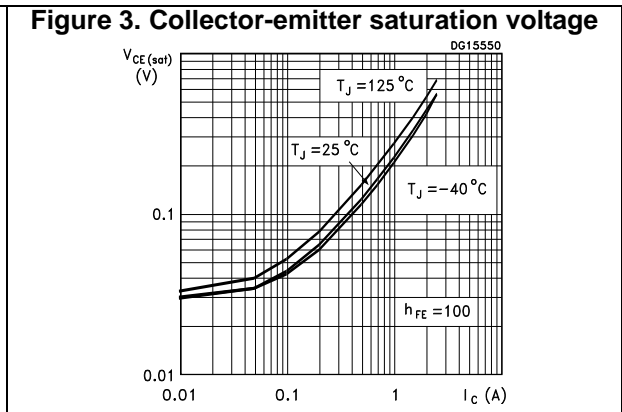
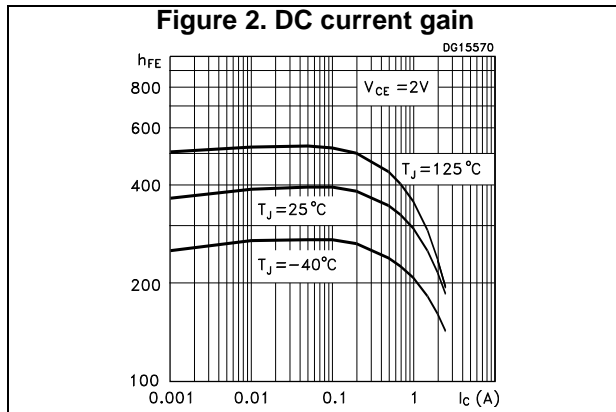

2.2 Test circuits

Figure 8. Resistive load switching test circuit

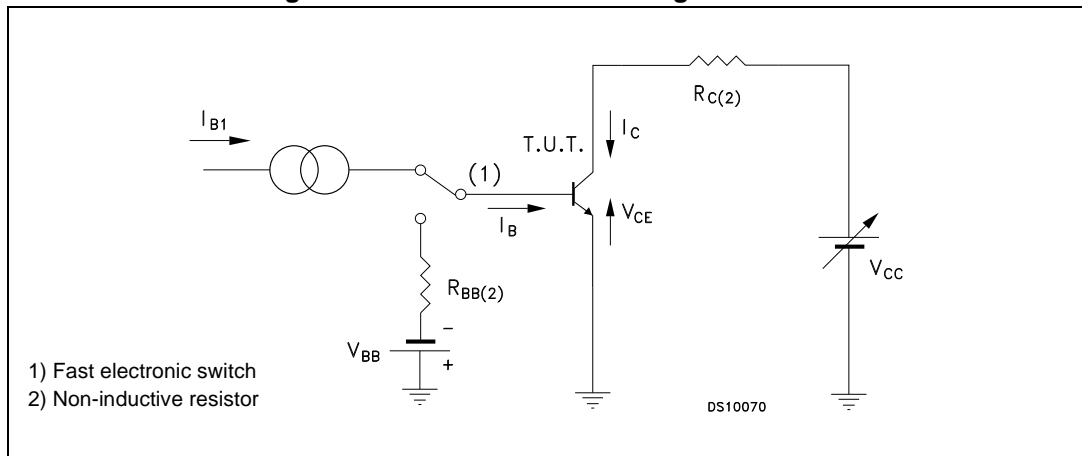

3 Package mechanical data

In order to meet environmental requirements, ST offers these devices in ECOPACK® packages. These packages have a Lead-free second level interconnect. The category of second level interconnect is marked on the package and on the inner box label, in compliance with JEDEC Standard JESD97. The maximum ratings related to soldering conditions are also marked on the inner box label. ECOPACK is an ST trademark. ECOPACK specifications are available at: www.st.com.

3.1 SOT-23 package information

Figure 9. SOT-23 package outline

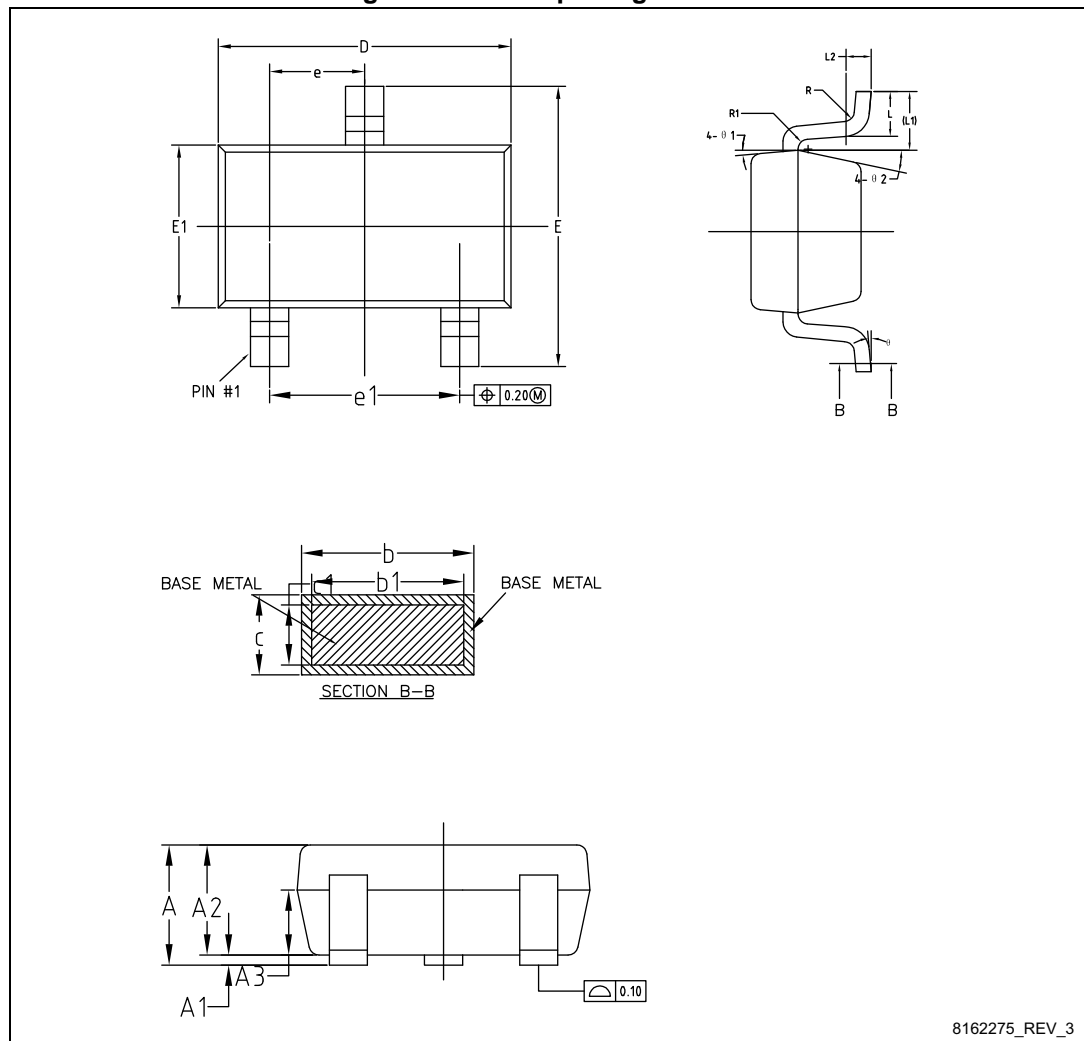
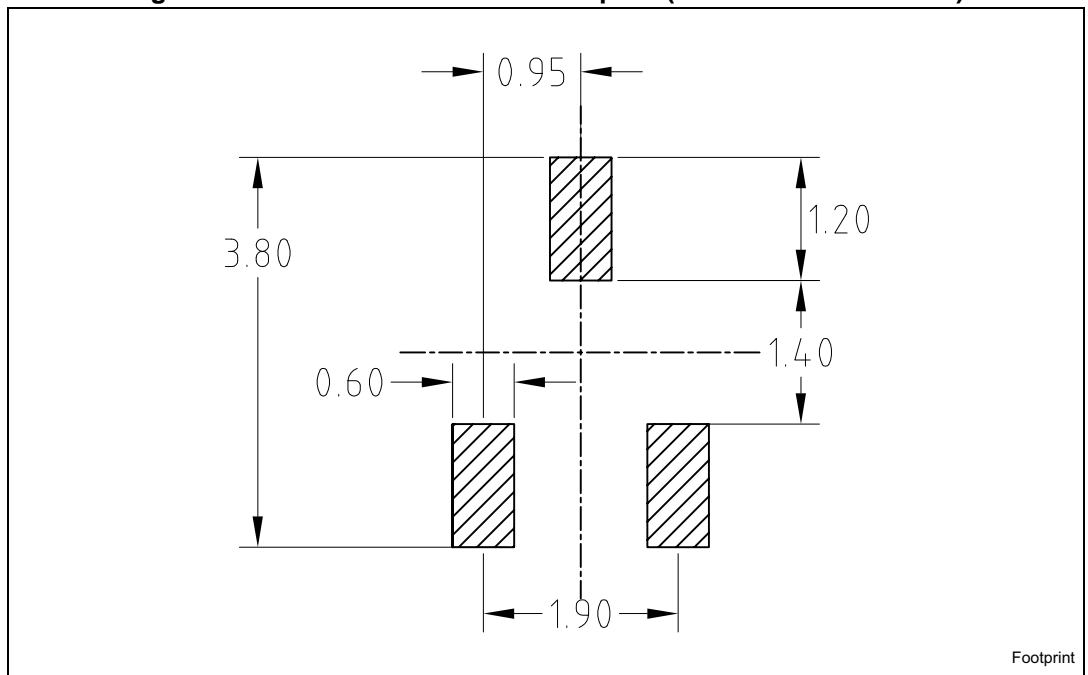

Table 5. SOT-23 mechanical data

Dim.	mm		
	Min.	Typ.	Max.
A			1.25
A1	0		0.15
A2	1	1.10	1.20
A3	0.60	0.65	0.70
b	0.36		0.50
b1	0.36	0.38	0.45
c	0.14		0.20
c1	0.14	0.15	0.16
D	2.826	2.926	3.026
E	2.60	2.80	3.00
E1	1.526	1.626	1.726
e	0.90	0.95	1.00
e1	1.80	1.90	2.00
L	0.35	0.45	0.60
L1	0.59 REF		
L2	0.25 BSC		
R	0.05		
R1	0.05		
Θ	0°		8°
$\Theta 1$	3°	5°	7°
$\Theta 2$	6°		14°

Figure 10. SOT-23 recommended footprint (dimensions are in mm)



4 Revision history

Table 6. Document revision history

Date	Revision	Changes
09-Feb-2006	1	Initial release
18-Jul-2006	2	New template
08-Sep-2008	3	Updated the SOT-23 mechanical data.
08-Jan-2009	4	Updated Figure 1: Internal schematic diagram Updated statement ECOPACK®
16-May-2016	5	Updated: description Updated: Table 1 Updated: Section 3.1: SOT-23 package information Minor text changes.