

Low voltage fast-switching PNP power transistor

Datasheet - production data

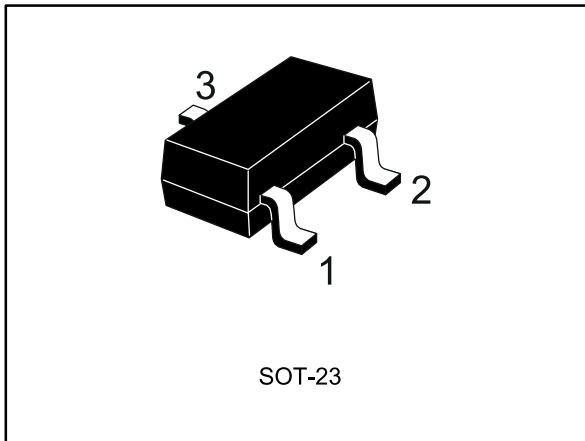
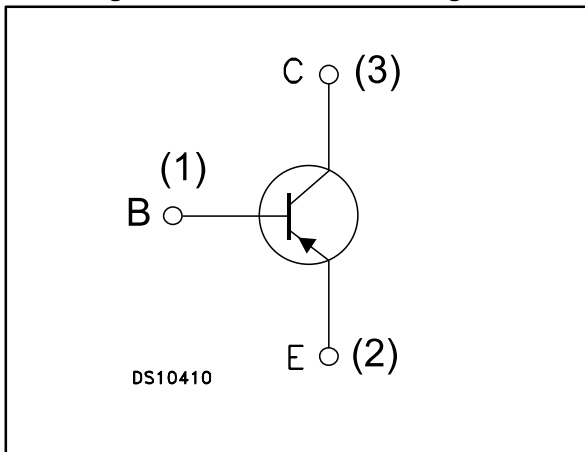

Figure 1: Internal schematic diagram



Features

- Very low collector-emitter saturation voltage
- High current gain characteristic
- Fast switching speed
- Miniature SOT-23 plastic package for surface mounting circuits

Applications

- LED
- Motherboard & hard disk drive
- Mobile equipment
- Battery charger
- Voltage regulation

Description

The device is a PNP transistor manufactured using new "PB-HCD" (power bipolar high current density) technology. The resulting transistor shows exceptional high gain performances coupled with very low saturation voltage.

Table 1: Device summary

Order code	Marking	Package	Packing
2STR2230	2230	SOT-23	Tape and reel

Contents

1	Electrical ratings	3
2	Electrical characteristics	4
	2.1 Electrical characteristics (curves).....	5
3	Package information	6
	3.1 SOT-23 package information	6
4	Revision history	9

1 Electrical ratings

Table 2: Absolute maximum rating

Symbol	Parameter	Value	Unit
V_{CES}	Collector-emitter voltage ($V_{CE} = 0$)	-30	V
V_{CEO}	Collector-emitter voltage ($I_B = 0$)	-30	V
V_{EBO}	Emitter-base voltage ($I_C = 0$)	-5	V
I_C	Collector current	-1.5	A
I_{CM}	Collector peak current ($t_P < 5\text{ms}$)	-3	A
P_{tot}	Total dissipation at $T_{amb} = 25^\circ\text{C}$	0.5	W
T_{stg}	Storage temperature range	-65 to 150	$^\circ\text{C}$
T_J	Operating junction temperature range		

Table 3: Thermal data

Symbol	Parameter	Value	Unit
$R_{thj-amb}^{(1)}$	Thermal resistance junction-amb max	250	$^\circ\text{C/W}$

Notes:

⁽¹⁾Device mounted on PCB area of 1 cm²

2 Electrical characteristics

($T_{\text{case}} = 25^{\circ}\text{C}$ unless otherwise specified)

Table 4: Electrical characteristics

Symbol	Parameter	Test conditions	Min.	Typ.	Max.	Unit
I_{CBO}	Collector cut-off current ($I_{\text{E}} = 0$)	$V_{\text{CB}} = -30 \text{ V}$			-0.1	μA
I_{EBO}	Emitter cut-off current ($I_{\text{C}} = 0$)	$V_{\text{EB}} = -4 \text{ V}$			-0.1	μA
$V_{(\text{BR})\text{CBO}}$	Collector-base breakdown voltage ($I_{\text{E}} = 0$)	$I_{\text{C}} = -100 \mu\text{A}$	-30			V
$V_{(\text{BR})\text{CEO}}^{(1)}$	Collector-emitter breakdown voltage ($I_{\text{B}} = 0$)	$I_{\text{C}} = -10 \text{ mA}$	-30			V
$V_{(\text{BR})\text{EBO}}$	Emitter-base breakdown voltage ($I_{\text{C}} = 0$)	$I_{\text{E}} = -100 \mu\text{A}$	-5			V
$V_{\text{CE}(\text{sat})}^{(1)}$	Collector-emitter saturation voltage	$I_{\text{C}} = -0.1 \text{ A}, I_{\text{B}} = -1 \text{ mA}$			-0.17	V
		$I_{\text{C}} = -1 \text{ A}, I_{\text{B}} = -100 \text{ mA}$		-0.25	-0.45	V
		$I_{\text{C}} = -2 \text{ A}, I_{\text{B}} = -200 \text{ mA}$		-0.42	-0.8	V
$V_{\text{BE}(\text{sat})}^{(1)}$	Base-emitter saturation voltage	$I_{\text{C}} = -1 \text{ A}, I_{\text{B}} = -100 \text{ mA}$		-0.9	-1.25	V
$h_{\text{FE}}^{(1)}$	DC current gain	$I_{\text{C}} = -50 \text{ mA}, V_{\text{CE}} = -2 \text{ V}$	210			
		$I_{\text{C}} = -0.5 \text{ A}, V_{\text{CE}} = -2 \text{ V}$	170	280	560	
		$I_{\text{C}} = -1 \text{ A}, V_{\text{CE}} = -2 \text{ V}$	100			
		$I_{\text{C}} = -1.5 \text{ A}, V_{\text{CE}} = -2 \text{ V}$	70			
f_{t}	Transition frequency	$I_{\text{C}} = -0.1 \text{ A}, V_{\text{CE}} = -5 \text{ V}$ $f = 100 \text{ MHz}$	100			MHz
C_{CBO}	Collector-base capacitance	$I_{\text{E}} = 0, V_{\text{CB}} = -10 \text{ V}$ $f = 1 \text{ MHz}$		10		pF
t_{on}	Turn-on time	Resistive load		74		ns
t_{off}	Turn-off time	$I_{\text{C}} = -1.5 \text{ A}, V_{\text{CC}} = -10 \text{ V}$ $I_{\text{B}1} = -I_{\text{B}2} = -150 \text{ mA}$		200		ns

Notes:

⁽¹⁾Pulse test: pulse duration = 300 μs , duty cycle $\leq 1.5 \%$

2.1 Electrical characteristics (curves)



For the PNP transistors, current and voltage polarities are reversed.

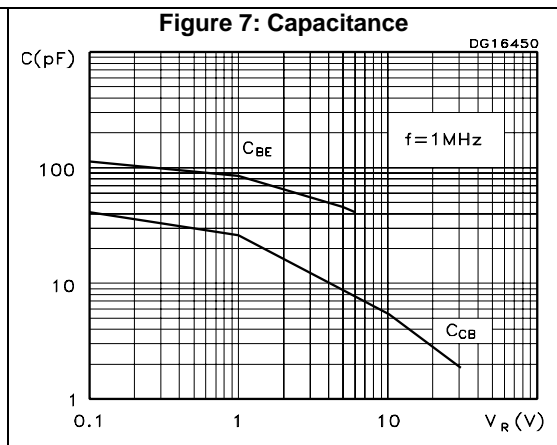
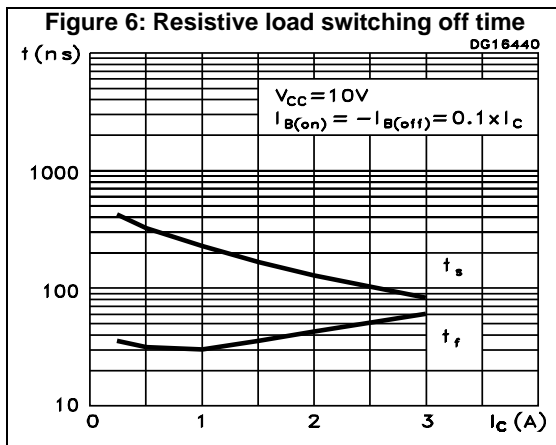
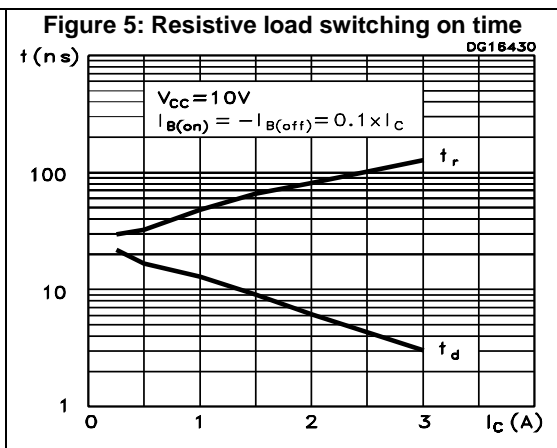
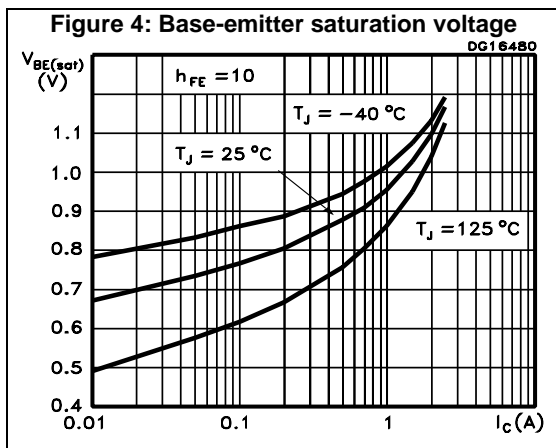
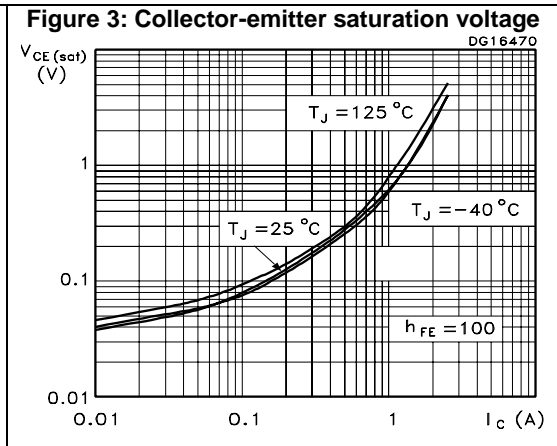
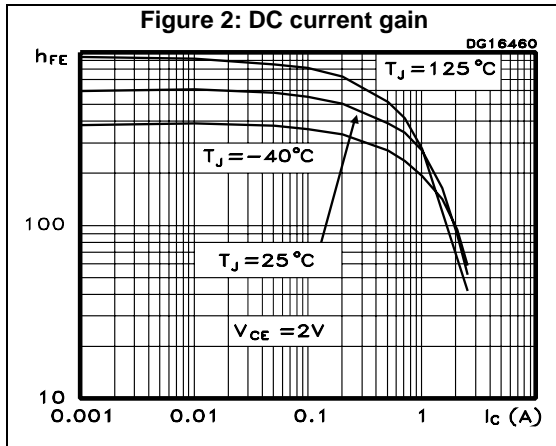

3 Package information

In order to meet environmental requirements, ST offers these devices in different grades of ECOPACK® packages, depending on their level of environmental compliance. ECOPACK® specifications, grade definitions and product status are available at: www.st.com. ECOPACK® is an ST trademark.

3.1 SOT-23 package information

Figure 8: SOT-23 package outline

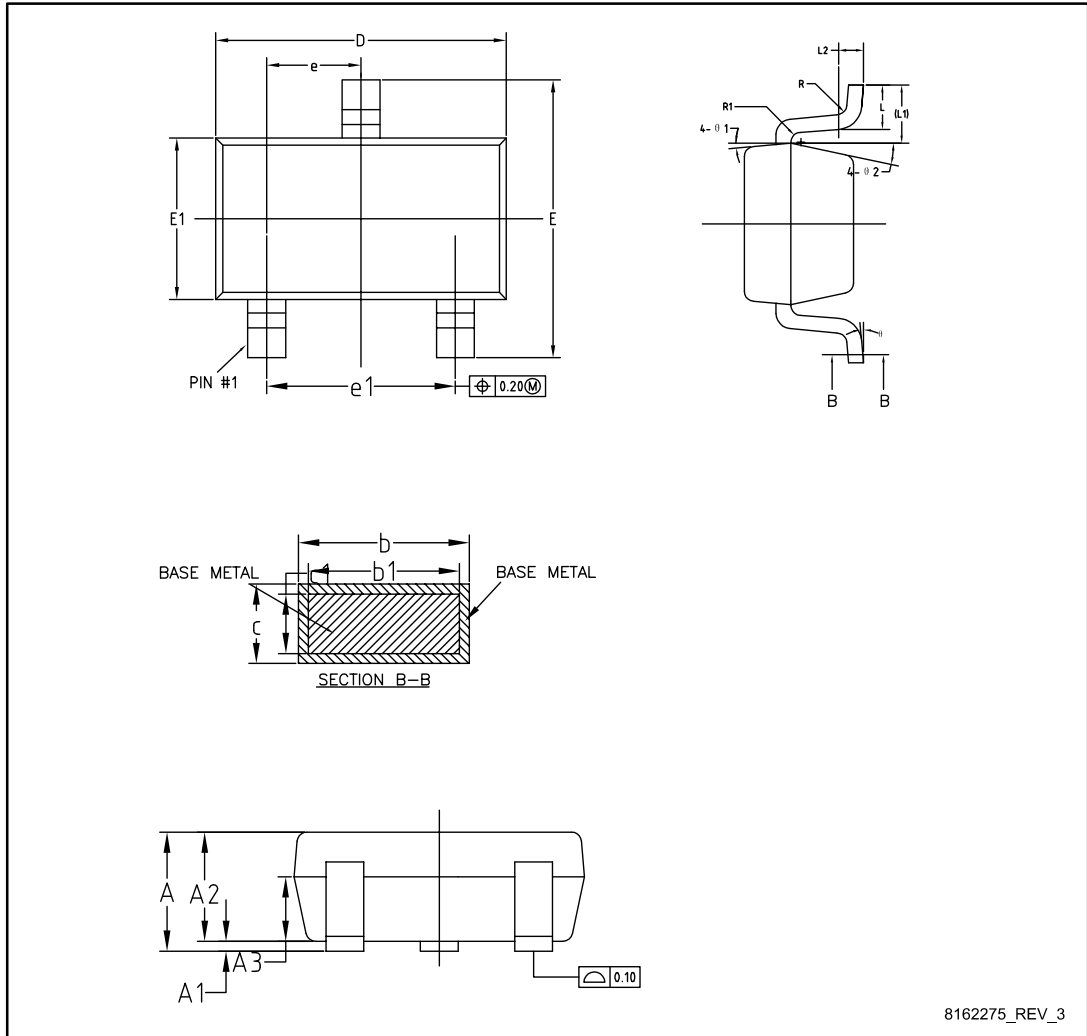

8162275_REV_3

Table 5: SOT-23 package mechanical data

Dim.	mm		
	Min.	Typ.	Max.
A			1.25
A1	0		0.15
A2	1	1.10	1.20
A3	0.60	0.65	0.70
b	0.36		0.50
b1	0.36	0.38	0.45
c	0.14		0.20
c1	0.14	0.15	0.16
D	2.826	2.926	3.026
E	2.60	2.80	3.00
E1	1.526	1.626	1.726
e	0.90	0.95	1.00
e1	1.80	1.90	2.00
L	0.35	0.45	0.60
L1		0.59 REF	
L2		0.25 BSC	
R	0.05		
R1	0.05		
θ	0°		8°
θ_1	3°	5°	7°
θ_2	6°		14°

Figure 9: SOT-23 recommended footprint (dimensions are in mm)

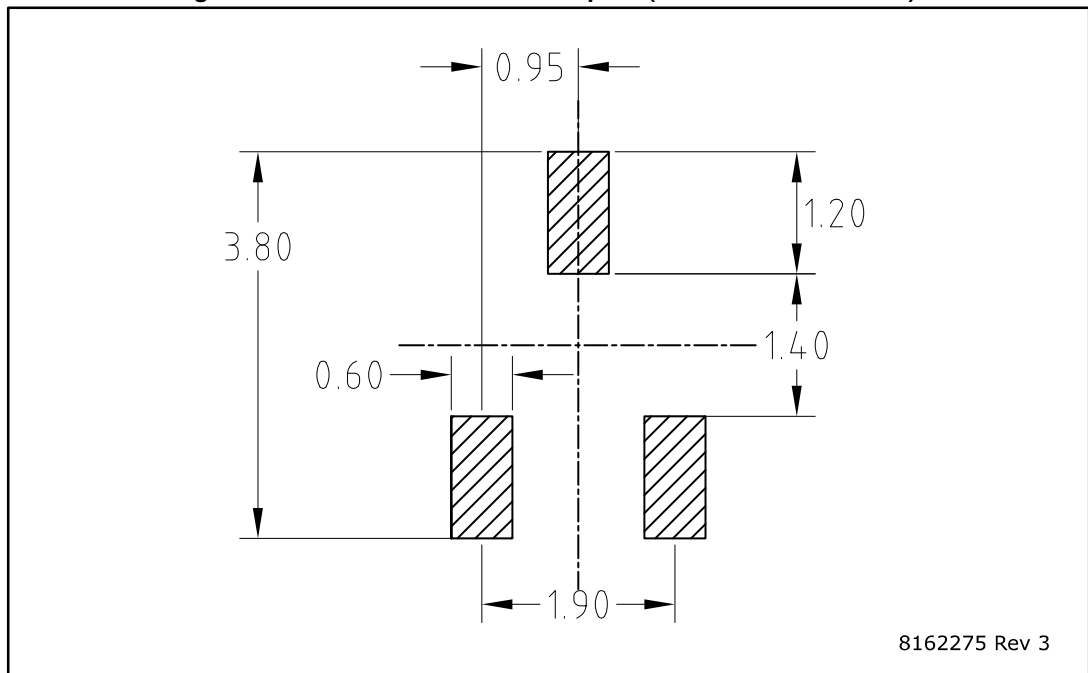

4 Revision history

Table 6: Document revision history

Date	Revision	Changes
18-Jul-2006	1	Initial release
31-Oct-2006	2	New graphics
07-Nov-2006	3	Maturity changed from preliminary to full.
09-Jun-2016	4	Updated features and description in cover page. Updated <i>Table 1: "Device summary"</i> . Updated <i>Section 3.1: "SOT-23 package information"</i> Minor text changes.
04-Jul-2016	5	Updated silhouette in cover page. Minor text changes.