

PART NAME: KNOB SCALE: 2:1 DATE: 9/10/95 DR. BY RF

THIS DRAWING IS THE PROPERTY OF DAVIES MOLDING COMPANY, IS SUBMITTED SOLELY AS A DESIGN OR ENGINEERING PROJECT. WE ACCEPT NO RESPONSIBILITY WHATSOEVER FOR THE PRACTICAL APPLICATION OF THE PIECES MADE TO THIS DESIGN.

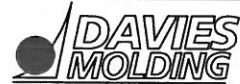

DESIGNERS & MANUFACTURERS OF KNOBS, HANDLES, CASES & CUSTOM PLASTIC COMPONENTS

P/N 3038-B

M NO. (8) CAV.MUD

CAVITY	3038
CORE	3038
SLEEVE	3038
PIN	3038
BUSHING	3038-G
PIN BAR	3038
CAVITY PLUG	3038-B
INSERT	11957

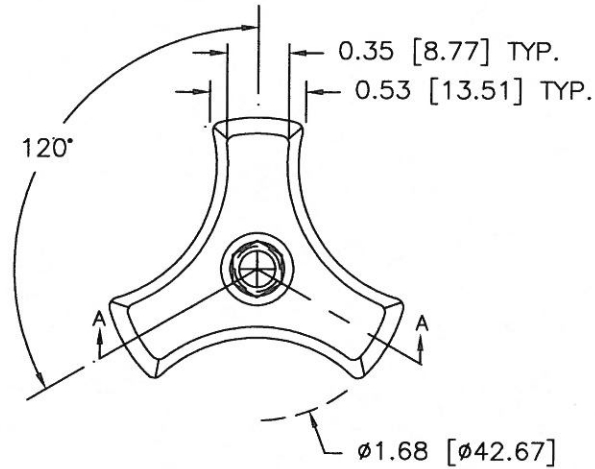

Ⓑ
Ⓔ

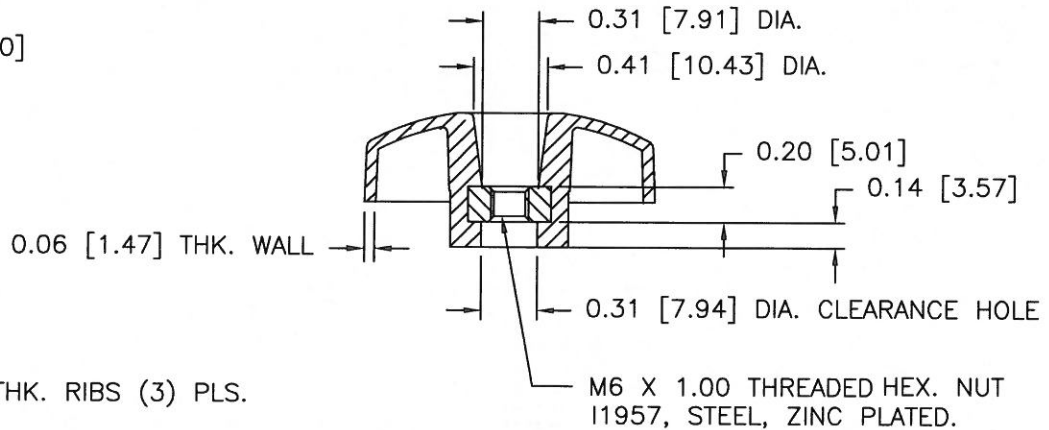
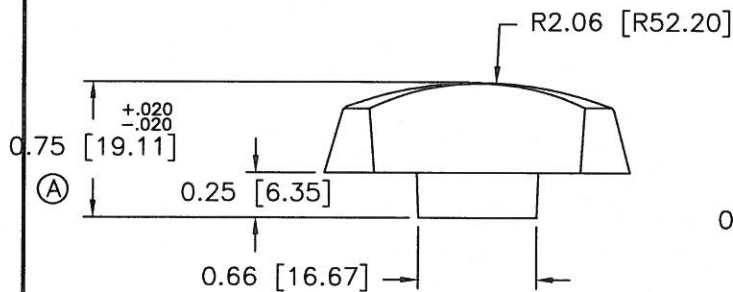

SECTION 'A-A'

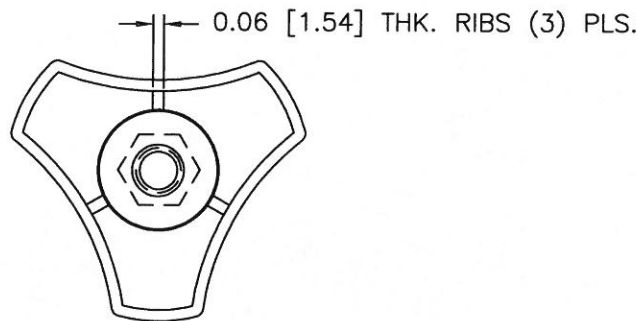

Ⓓ MATERIAL: 20% Talc Filled Polypropylene
COLOR: Black

TOLERANCES: UNLESS OTHERWISE SPECIFIED	DO NOT SCALE DRAWING
DECIMALS: X.XXX ± .005 X.XX ± .015	MM: X.XX ± 0.15MM X.X ± 0.4MM
FRACTIONS ± 1/64	ANG. ± 1°

E	ADDED BUSHING	ST	7/09/01
D	WAS HIPS	TL	4/20/99
C	MAT'L REVI WAS POLYPROPYLENE	HD	1/29/96
B	WAS #3038-B PINS	HD	1/10/96
A	UPDATED DWG. W/ ADDED TOLERANCES	HD	12/13/95

CHANGES