

THIS DOCUMENT IS THE PROPERTY OF KEYSTONE ELECTRONICS CORP. AND SHALL NOT BE REPRODUCED, DISTRIBUTED OR USED AS A BASIS FOR MANUFACTURE WITHOUT PRIOR WRITTEN PERMISSION FROM KEYSTONE ELECTRONICS CORP.

ACTUAL SIZE

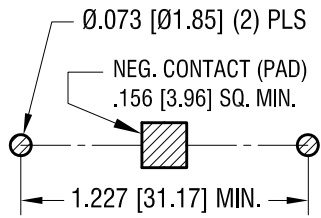

MOUNTING PAD LAYOUT

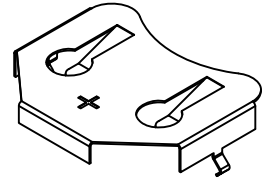
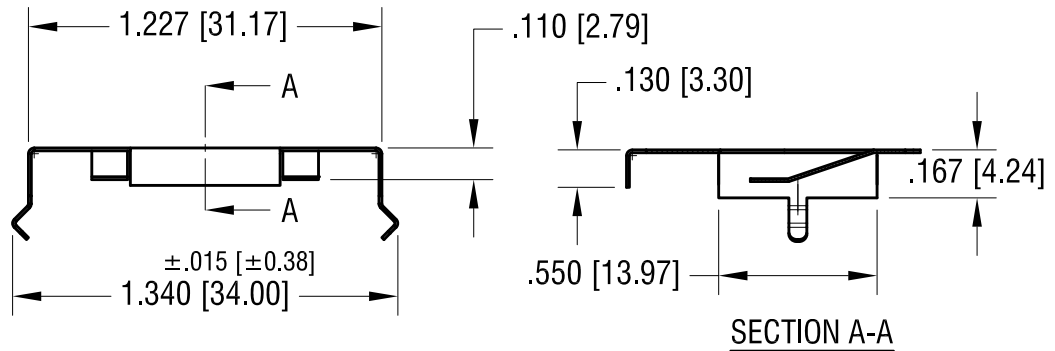
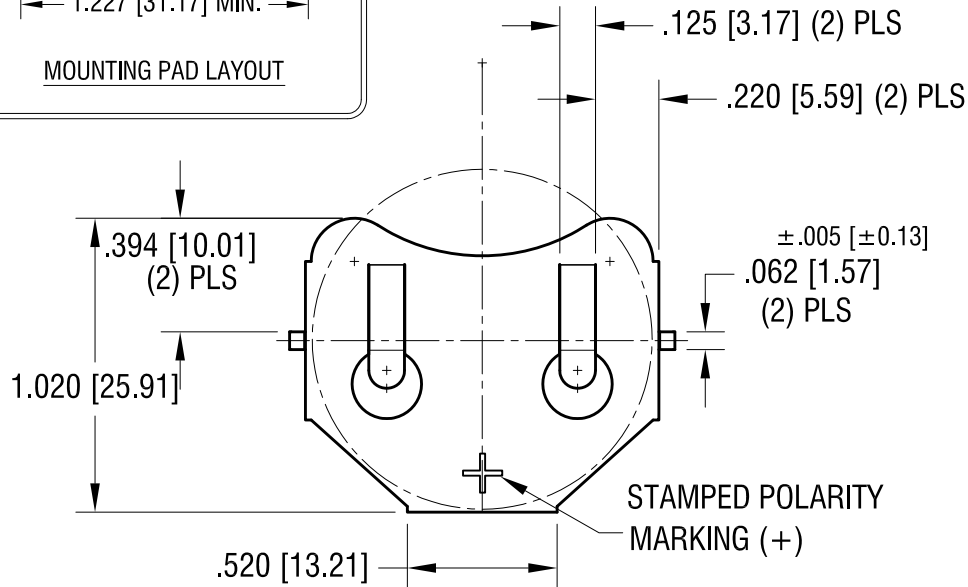

SECTION A-A

**KEYSTONE ELECTRONICS CORP.**

www.keyelco.com • ASTORIA, N.Y. 11105-2017 • Tel (718) 956-8900

PART NAME

30 mm THM COIN CELL CLIP

MATERIAL

.010 [0.25] TH'K PHOSPHOR BRONZE

FINISH

TIN NICKEL PLATE

DRN BY

NT

DATE

4.28.16

APP'D

RH

SCALE

1.5X

TOLERANCES

INCH [MM]

DECIMAL

± .010 [± 0.25]

ANGULAR

± 1°

UNLESS OTHERWISE SPECIFIED

CODE

C

DWG NO.

3047

DATE

DESCRIPTION

REV.