

REV	DESCRIPTION\PER REQUEST	DRAWN	DATE

**CRIMP SIZES REQUIRED**  
**CONTACT: .068" [1.72mm]**  
**FERRULE: .213" [5.41mm]**

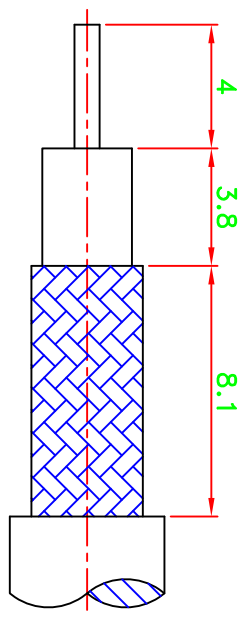

**RECOMMENDED**  
**CABLE STRIPPING DIM'S**

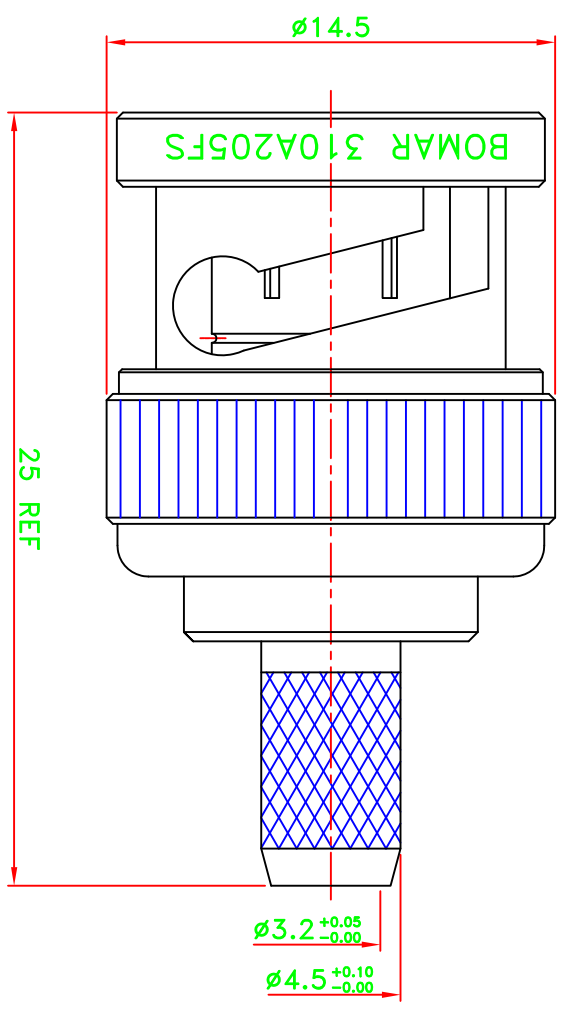
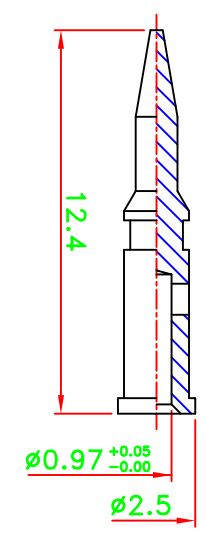

NO	Description	Qty	Material	Finish
9	Gasket	1	Rubber	Red
8	Retaining ring	1	SK-5	Nickel
7	Spring	1	SK-5	Nickel
6	Washer	1	Brass	Nickel
5	Shell	1	Brass	Nickel
4	Ferrule	1	Brass	Nickel
3	Dielectric	1	Delrin	None
2	Pin	1	Brass	Gold
1	Body	1	Brass	Nickel

B-106K1

PART NO.	310A205FS	* MAJOR DIMENSION
APPROVED	DATE 01/08/14	UNLESS OTHERWISE NOTED TOLERANCES
CHECKED	DATE 01/08/14	0.5-6 = ±0.2
DRAWN	DATE 01/08/14	6-30 = ±0.4
		30-120 = ±0.6
		120-315 = ±1.0
		ANGLES = ±1°

Bomar Interconnect Products, Inc	
TITLE	BNC CRIMP PLUG (50 ohm)
DRAWING NO.	BNC-1301-12-DGN
FILE NO.	W:\DWG\COMPOSE\BNC\BNC-1301-12-DGN Winchester-->20140107
REV	D

