

Description

Single, two and three pole rocker switch/thermal trip free circuit breakers (S-type TO CBE to EN 60934) of compact design for snap-in panel mounting. Available either with protection on one/both/all poles or, in the case of the double pole version, protection on one pole only. Illumination is optional and there is a choice of rocker colours. Approved to CBE standard EN 60934 (IEC 60934).

Typical applications

Motors, transformers, solenoids, household and office machines, electrical tools, mobile homes, boats, construction vehicles, medical equipment to EN 60601.

Features and benefits

- Single pole, double pole or three-pole thermal circuit breaker/switch combination
- Voltage ratings AC 240 V; 3 AC 415 V; DC 50 V
- Can be combined with X3120 Power Entry Module. Please refer to the respective section in this document.

Approvals



Compliances



Your benefits

- Maximum equipment availability is ensured by overload protection perfectly matched with the loads (prevention of nuisance tripping) and quick resettability
- Reduced mounting and wiring time
- Less space requirement
- Less disposition and storage costs
- Enhanced overall reliability

Information online

The current data sheet is available on our website:
www.e-t-a.de/d001

Technical data

For further details please see: www.e-t-a.de/ti_e

Voltage rating	AC 240 V; 3 AC 415 V; DC 50 V (UL: AC 250 V; 3 AC 250 V; DC 50 V)
Current ratings	0.1...20 A 1-pole 0.1...16 A 2- and 3-pole

Typical life 1-pole (IEC/EN 60934)

AC 240 V:	0.1...20 A	30,000 operations at 1 x I _N , inductive
DC 50 V:	0.1...4 A	30,000 operations at 1 x I _N , inductive
	4.5...16 A	30,000 operations at 1 x I _N , resistive
DC 28 V:	0.1...20 A	30,000 operations at 1 x I _N , inductive

Typical life 2-pole (IEC/EN 60934)

AC 240 V:	0.1...16 A	50,000 operations at 1 x I _N , inductive
DC 50 V:	0.1...16 A	50,000 operations at 1 x I _N , inductive

Typical life 3-pole (IEC/EN 60934)

3 AC 415 V:	0.1...16 A	30,000 operations at 1 x I _N , inductive
-------------	------------	---

Ambient temperature	-30...+60 °C (-22...+140 °F)	
Insulation co-ordination (IEC 60664 and 60664 A)	rated impulse withstand voltage 2.5 kV reinforced insulation in operating area	pollution degree 2

Dielectric strength (IEC 60664 and 60664 A)	test voltage
operating area	AC 3,000 V
current path/current path	AC 1,500 V

Insulation resistance	> 100 MΩ (DC 500 V)
-----------------------	---------------------

Interrupting capacity I_{CN} (EN 60934)

	I _N	U _N	I _{CN}
1, 2, 3-pole	0.1...2 A	AC 240 V/3 AC 415 V	10 x I _N
1 pole	2.5...20 A	AC 240 V	200 A
2 pole	2.5...16 A	AC 240 V	300 A
3 pole	2.5...12 A	3 AC 415 V	150 A
3 pole	14...16 A	3 AC 415 V	130 A





Technical data

Rupture capacity I_{NC} (UL1077)

	I _N	U _N	I _{nc}
1, 2-pole	0.1...16 A	AC 250 V	3 500 A, C, 1
3-pole	0.1...12 A	3 AC 250 V	5 000 A, C, 1
1,2-pole	0.1...16 A	DC 50 V	2 000 A, C, 1

Degree of protection (IEC 60529/DIN 40050)	operating area IP40 terminal area IP00
Vibration	5 g (57-500 Hz) ± 0.38 mm (10-57 Hz) to IEC 60068-2-6, test Fc 10 frequency cycles/axis
Shock	1-pole: 25 g (11 ms) 2 + 3-pole: 20 g (11 ms) to IEC 60068-2-27, test Ea
Corrosion	96 hours at 5 % salt mist, to IEC 60068-2-11, test Ka
Humidity	240 hours at 95 % RH, to IEC 60068-2-78, test Cab
Mass	approx. 45 g (three pole) approx. 31 g (double pole) approx. 17 g (single pole)

Approvals

Authority	Standard	Rated voltage	Current ratings	Approval logos
VDE	IEC/EN 60934	AC 240 V AC 240 V 3 AC 415 V DC 50 V DC 28 V	0.1 A...20 A (1-pole) 0.1A...16 A (2-pole) 0.1A...16 A (3-pole) 0.1A...16 A (1-, 2-pole) 0.1 A...20 A (1-pole)	
UL	UL 1077	AC 250 V AC 250 V DC 50 V	0.1 A...16 A (1 + 2 pole)* 0.1 A...12 A (3 pole)* 0.1 A...16 A (1 - 3 pole)*	
CSA	C22.2 No 235	AC 250 V AC 250 V DC 50 V	0.1 A...16 A (1-, 2- pole)** 0.1 A...12 A (3-pole)* 0.1 A...16 A (1-, 2-, 3-pole)***	
CQC	GB/T 17701	AC 240 V AC 240 V 3 AC 415 V DC 50 V	0.1 A...20 A (1-pole) 0.1A...16 A (2-pole) 0.1A...16 A (3-pole) 0.1A...16 A (1-, 2-pole)	

* TC2, OL 1

** TC2, 0,1A-12 A: OL1, >12 A: OL0

*** TC2, OL0

Ordering information - 1-pole

Type No.	
3130	single pole thermal circuit breaker
Mounting	
F	Snap-in frame
Frame	
1	Standard, panel cut-out 14.6 x 34 mm
3	Panel cut-out 18.0 x 35-37 mm
Number of poles	
1	single pole, thermally protected
Frame mounting	
0	Snap-in frame, black, panel thickness 1.0-2.5 mm, for frame size 1
1	Snap-in frame, black, panel thickness 1.5-3.2 mm, for frame size 3
Terminal design	
P7	blade terminals DIN 46244-C-Ms-S (QC 2x.110)
H7	for terminals 1.1, 2.1 3.1 terminal screws M 3.5 for terminals 1.2, 2.2, 3.2 blade terminals (QC 2x.110)
Characteristic curve	
T1	thermal
Actuator style	
W	rocker switch with marking „I“ and „O“ moulded in
Actuator colour	
01 Q	black opaque without illumination
02 Q	white opaque without illumination
04 Q	red opaque without illumination
14 Q R	red translucent with LED-illumination
15 Q Y	orange translucent with LED-illumination
19 Q G	green translucent with LED-illumination (DC only)
Illumination voltage range*	
2	10 - 14 V DC
3	20 - 28 V DC
6	90 - 140 V AC
7	185 - 275 V AC
Current ratings	
0.1...20 A	
3130 - F 1 1 0 - P7 T1 - W 14 Q R 3 - 5 A ordering example	

Please observe our minimum ordering quantities

* N/A for non-illuminated version

Custom designed versions

Looking for a version you cannot find in our order numbering key? Please get in touch. We will be pleased to find a solution for you.

Ordering information - multipole

Type No.	
3130	multipole thermal circuit breaker
Mounting	
F	Snap-in frame
Frame	
1	Standard, panel cut-out size depending on no. of poles
A	version for X3130
Number of poles	
2	2-pole thermally protected
3	3-pole thermally protected
5	2-pole, 1-pole thermally protected
Frame mounting	
0	Snap-in frame, black, panel thickness 1.0-2.5 mm for frame size 1
A	2-pole, version for X3130
Terminal design	
P7	blade terminals DIN 46244-C-Ms-S (characteristic curve T1)
H7	for terminals 1.1, 2.1 3.1 terminal screws M 3.5 for terminals 1.2, 2.2, 3.2 blade terminals (QC 2x.110)
Characteristic curve	
T1	thermal
Actuator style	
W	rocker switch with marking „I“ and „O“ moulded in
Actuator colour	
01 Q	black opaque without illumination
02 Q	white opaque without illumination
04 Q	red opaque without illumination
14 Q R	red translucent with LED-illumination
15 Q Y	orange translucent with LED-illumination
19 Q G	green translucent with LED-illumination
Illumination voltage range*	
2	10 - 14 V DC
3	20 - 28 V DC
6	90 - 140 V AC
7	185 - 275 V AC
8	320 - 450 V AC
Current ratings	
0.1...16 A	
3130 - F 1 3 0 - P7 T1 - W 14 Q R 7 - 5 A ordering example	

Please observe our minimum ordering quantities

* N/A for non-illuminated version

ETA 3130 Thermal Overcurrent Circuit Breaker

Standard current ratings and typical internal resistance values

Current rating (A)	Internal resistance per pole (Ω)	Current rating (A)	Internal resistance per pole (Ω)
0.1	94	4	0.0435
0.2	24	5	0.0325
0.3	12	6	0.0215
0.4	5.30	7	0.0165
0.5	4.20	8	0.0165
0.8	1.50	10	< 0.02
1	0.9	12	< 0.02
1.2	0.80	14	< 0.02
1.5	0.45	15	< 0.02
2	0.27	16	< 0.02
2.5	0.0785	18	< 0.02
3	0.0595	20	< 0.02
3.5	0.0565		

Dimensions 3130-F110-...

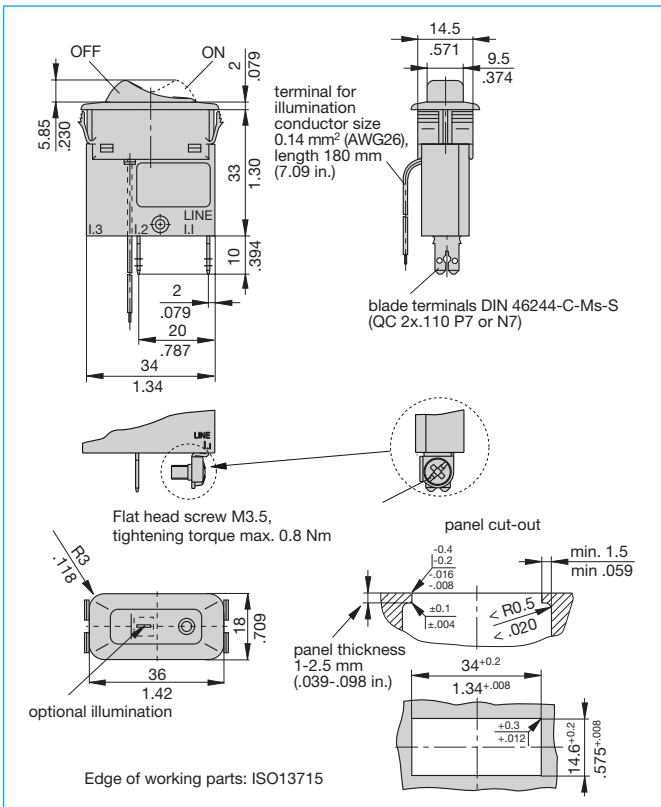

Dimensions 3130-F311-...

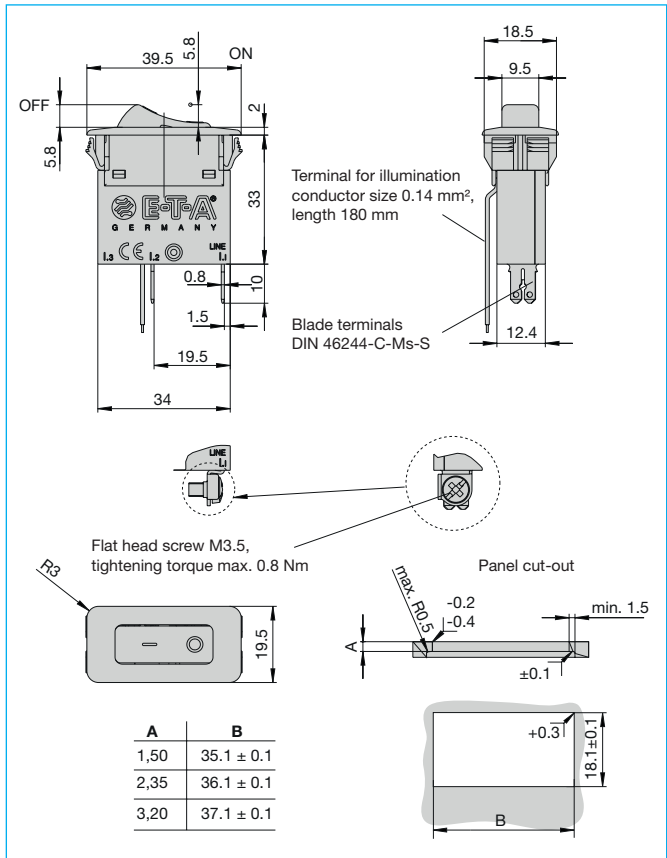

Dimensions 3130-F120-...

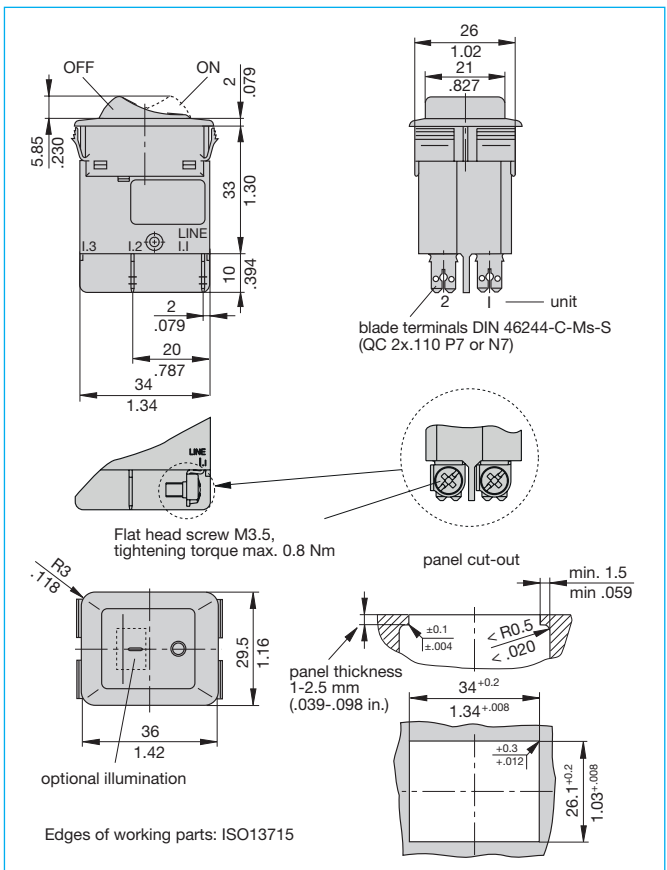

Dimensions 3130-F130-...

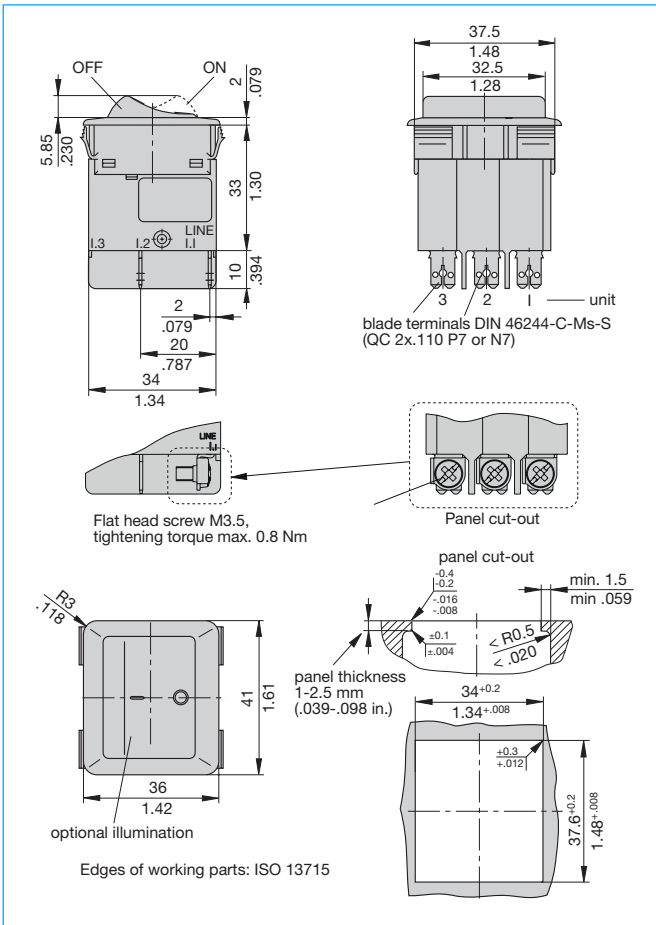

Internal connection diagrams

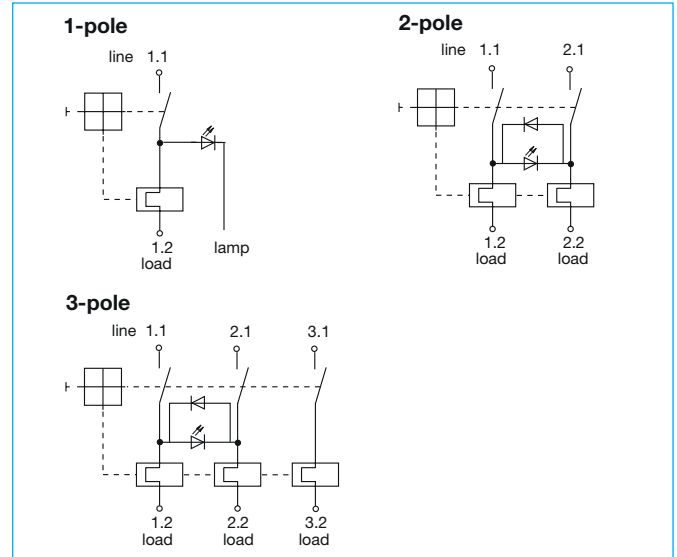

Accessories 3130-F130-...

Splash cover, transparent, for 3-pole version X 221 258 01 (IP54), comprising bezel Y 306 109 01 and transparent cover Y 306 108 01

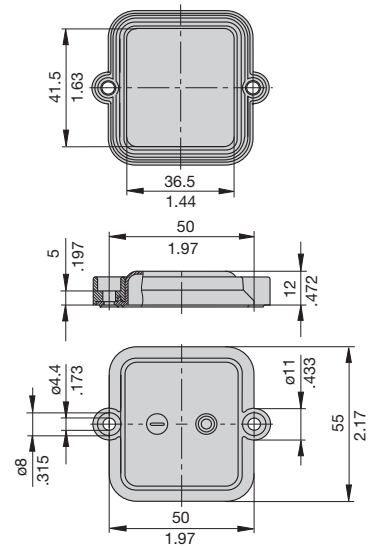

Installation drawing 3130-F1...

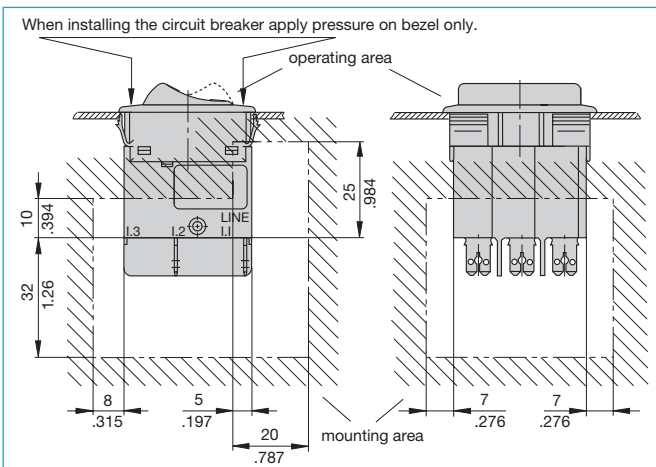

Typical time/current characteristics

Multipole types: all poles symmetrically loaded.
 With single pole overload, thermal tripping will be at approx. $1.54 \times I_N$ with 2-pole devices and at approx. $1.68 \times I_N$ with 3-pole devices.

0.1...2 A

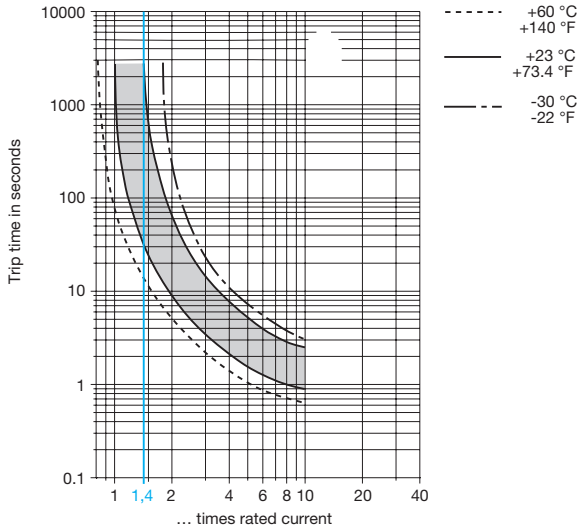

2.5...20 A 1-pole 2.5...16 A 2- and 3-pole

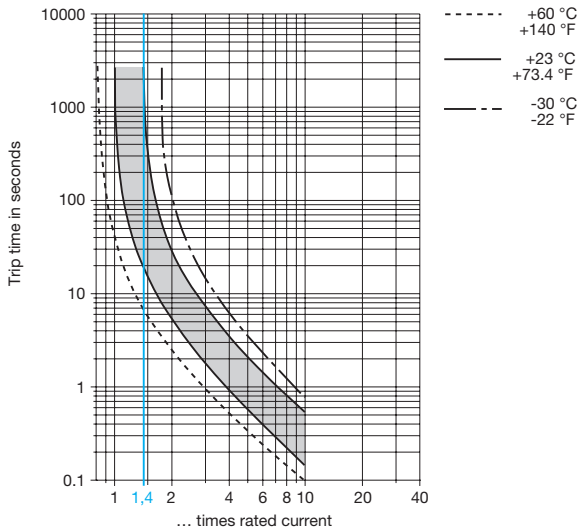

The time/current characteristic curve depends on the ambient temperature prevailing. In order to eliminate nuisance tripping, please multiply the circuit breaker current ratings by the derating factor shown below. See also section Technical information.

Ambient temperature	°F	-22	-4	+14	+32	+73.4	+104	+122	+140
°C	-30	-20	-10	0	+23	+40	+50	+60	
Derating factor	0.8	0.84	0.88	0.92	1	1.08	1.14	1.23	

This is a metric design and millimeter dimensions take precedence ($\frac{\text{mm}}{\text{inch}}$)

All dimensions without tolerances are for reference only. In the interest of improved design, performance and cost effectiveness the right to make changes in these specifications without notice is reserved. Product markings may not be exactly as the ordering codes. Errors and omissions excepted.