

Features

- Surface Mount 4 mm Square / Multiturn Cermet / Industrial / Sealed
- Halogen free** with date code 114
- Sealed to withstand board wash processing
- Pick and place centering design, with flush adjustment
- 4 mm design meets EIA/EIAJ/IPC/VECI SMD standard trimmer footprint
- RoHS compliant* - see [processing information](#) on RoHS compliant surface mount trimmers
- For trimmer applications/processing guidelines, [click here](#)

3214 - 5-Turn Trimpot® Trimming Potentiometer

Electrical Characteristics

Standard Resistance Range 10 ohms to 2 megohms
 (see standard resistance table)
 Resistance Tolerance ±10 % std.
 Absolute Minimum Resistance 1 % or 2.0 ohms (whichever is greater)
 Contact Resistance Variation 3 % or 3 ohms max.
 Resolution Essentially Infinite
 Insulation Resistance 500 vdc.
 100 megohms min.
 Dielectric Strength
 Sea Level 600 vac (1 minute)
 Adjustment Angle5 turns nom.

Environmental Characteristics

Power Rating (300 volts max.)
 85 °C 0.25 watt
 150 °C 0 watt
 Temperature Range -65 °C to +150 °C
 Temperature Coefficient ±100 ppm/°C
 Seal Test 85 °C Fluorinert†/60 seconds
 Humidity MIL-STD 202 Method 106
 TRS ±2 %; IR 10 megohms
 Vibration 20 G TRS±1 %; VRS ±1 %
 Shock 100 G TRS ±1 %; VRS±1 %
 Load Life
@ 85 °C rated power 1,000 hours
 TRS 3 ohms or 3 % (whichever is greater)
 Rotational Cycling 200 cycles
 TRS 3 ohms or 3 % (whichever is greater)
 Thermal Shock 5 cycles
 TRS ±2 %; VRS ±1 %
 Moisture Sensitivity Level 1
 ESD Classification 2

Physical Characteristics

Mechanical Stop Wiper idles
 Torque 180 g-cm max.
 Weight Approximately 0.01 oz.
 Marking Manufacturer's code,
 resistance code and date code
 Solderability Per MIL-STD-202,
 Method 208
 Wiper 50 % (Actual TR) ±10 %
 Flammability UL94V0
 Pushover Strength
 J, G 4.4 lbs.
 W, X 1 lb.
 Adjustment Tool H-91

DIMENSIONS: $\frac{\text{MM}}{\text{(INCHES)}}$

TOLERANCES: ± $\frac{0.25}{(.010)}$ EXCEPT WHERE NOTED

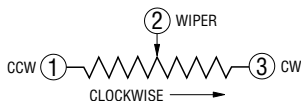

Product Dimensions

3214J Side Adjust

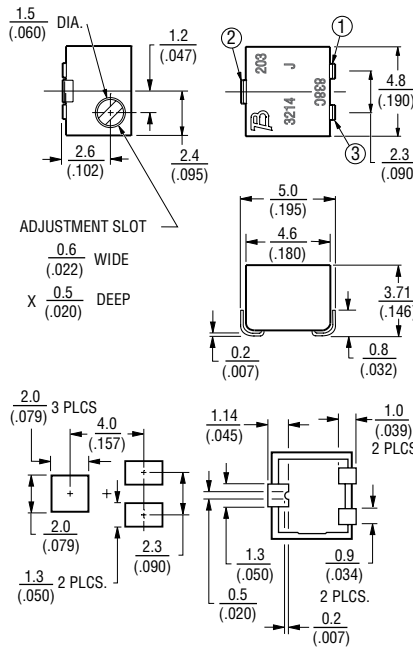

3214G Side Adjust

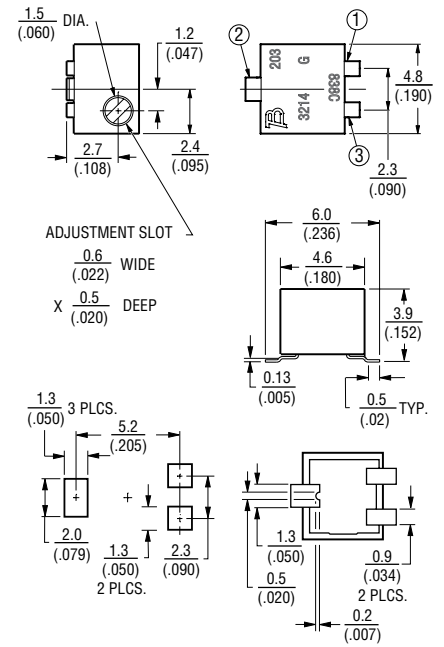

3214W Top Adjust

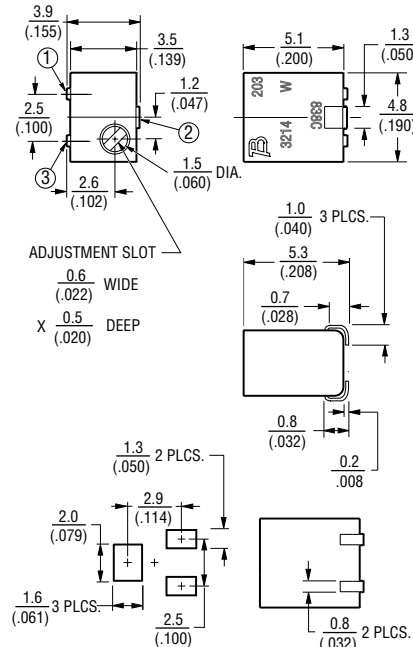

3214X Top Adjust

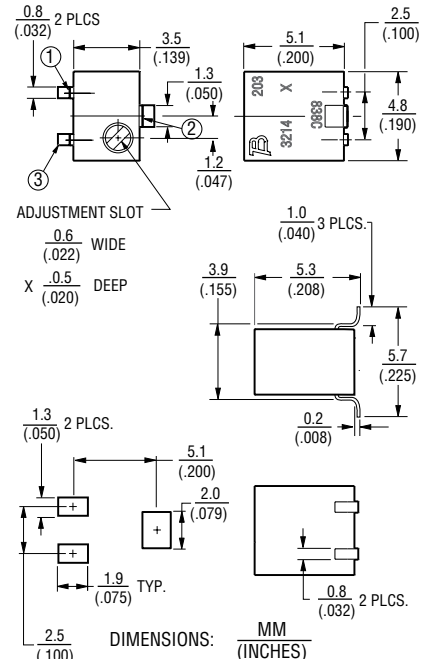

* RoHS Directive 2015/863, Mar. 31, 2015 and Annex
 ** Bourns follows the prevailing definition of "halogen free" in the industry. Bourns considers a product to be "halogen free" if (a) the Bromine (Br) content is 900 ppm or less; (b) the Chlorine (Cl) content is 900 ppm or less; and (c) the total Bromine (Br) and Chlorine (Cl) content is 1500 ppm or less.
 †Fluorinert is a trademark of Bourns, Inc. ††Fluorinert is a registered trademark of 3M Co.
 Specifications are subject to change without notice. Users should verify actual device performance in their specific applications. The products described herein and this document are subject to specific legal disclaimers as set forth on the last page of this document, and at www.bourns.com/docs/legal/disclaimer.pdf.



3214 - 5-Turn Trimpot® Trimming Potentiometer

BOURNS®

Packaging Specifications

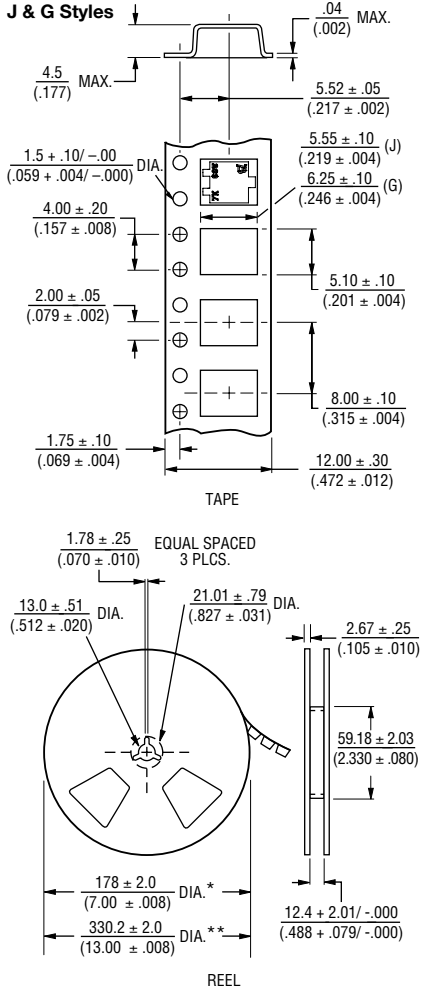

* Embossed Tape Designator "E"
 ** Embossed Tape Designator "G"
 (See How To Order chart for further information.)

Cover tape peel strength: Meets EIA specification 481.

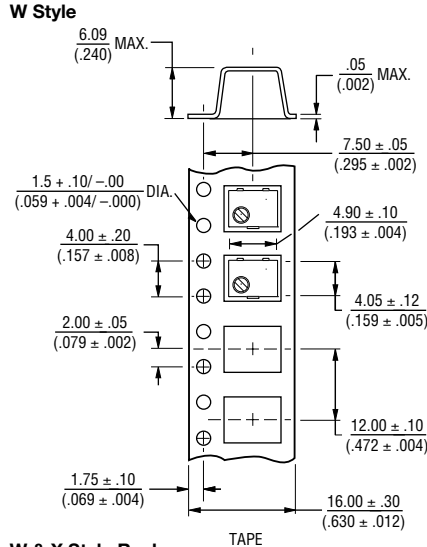

W & X Style Reel

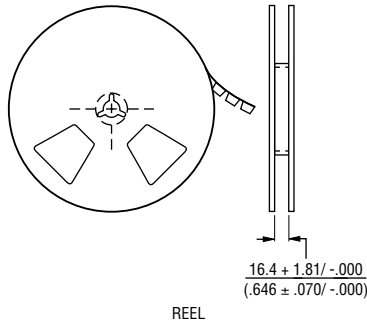

* Embossed Tape Designator "E"
 ** Embossed Tape Designator "G"
 (See How To Order chart for further information.)

Cover tape peel strength: Meets EIA specification 481.

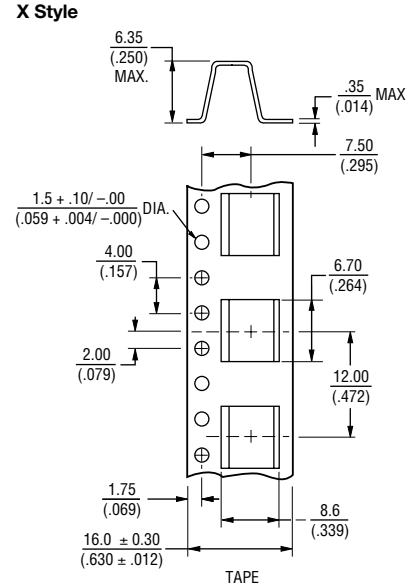

How To Order

Model **3214 J - 1 - 502 E**
 Style _____
 Standard or Modified _____
 Product Indicator
 -1 = IR Reflow (standard)
 †-2 = Wave Solderable
 -FW5 = .070" ± .010" Shaft Extension
 Resistance Code _____

Embossed Tape Designator

E = Style J, G: 500 pcs./7" reel (standard)
 Style W: 250 pcs./7" reel (standard)
 Style X: 200 pcs./7" reel (standard)
 G = Style J, G: 1500 pcs./13" reel (standard)
 Style W: 1000 pcs./13" reel (standard)
 Style X: 850 pcs./13" reel (standard)
 G = Style J, G: 1500 pcs./13" reel (FW5)
 Style W, X: 600 pcs./13" reel (FW5)

Consult factory for other available options.

†-2 has a treated stainless steel shaft

Tape and reel material meets Antistatic ANSI/ESD 5541-2003 packaging standards.

Standard Resistance Table

Resistance (Ohms)	Resistance Code
10	100
20	200
50	500
100	101
200	201
500	501
1,000	102
2,000	202

Resistance (Ohms)	Resistance Code
5,000	502
10,000	103
20,000	203
50,000	503
100,000	104
200,000	204
500,000	504
1,000,000	105
2,000,000	205

Popular distribution values listed in boldface.
 Special resistances available.

Specifications are subject to change without notice. Users should verify actual device performance in their specific applications. The products described herein and this document are subject to specific legal disclaimers as set forth on the last page of this document, and at www.bourns.com/docs/legal/disclaimer.pdf.