

1 Scope

The standard open type transducers provide high sensitivity, wider bandwidth, and excellent durability in wide temperature and humidity ranges and high stability in electrical and mechanical characteristics. Due to its free vibration character the open type transducers are very suitable for continual wave driving, such as Doppler motion detector.

2 Part Number

328ST18M / **328SR18M** Open Type Air Ultrasonic Ceramic Transducer

3 Dimension

As per Figure 1

4 Specification

(rated at temperature $25\pm 3^{\circ}\text{C}$, 45 to 60% RH, unless otherwise noted)

Model Number: 328ST18M			
	Items	Specification	Remarks
4-1	Center Frequency	32.8KHz \pm 1KHz	HP4192A Impedance analyzer
4-2	Sound Pressure Level	117dB (min)	at 32.8KHz; 0dB re 0.0002 μ bar per 10Vrms at 30cm 10Vrms sine wave input detail see attached Figure 2
4-3	Bandwidth	2.0KHz (min)	-6dB
4-4	Capacitance	2600pF	\pm 20%, measured at 1KHz
4-5	Total Beam Angle	45 $^{\circ}$ (TYP.)	-6dB
4-6	Operation Temperature	-30 $^{\circ}\text{C}$ to +70 $^{\circ}\text{C}$	
4-7	Storage Temperature	-40 $^{\circ}\text{C}$ to +80 $^{\circ}\text{C}$	

Model Number: 328SR18M			
	Items	Specification	Remarks
4-8	Center Frequency	32.8KHz \pm 1Hz	HP4192A Impedance analyzer
4-9	Sensitivity	-64dB (min)	at 32.8KHz; 0dB=1Volt/ μ bar detail see attached Figure 3
4-10	Bandwidth	2.0KHz (min)	-6dB
4-11	Capacitance	2600pF	\pm 20%, measured at 1KHz
4-12	Operation Temperature	-30 $^{\circ}\text{C}$ to +70 $^{\circ}\text{C}$	
4-13	Storage Temperature	-40 $^{\circ}\text{C}$ to +80 $^{\circ}\text{C}$	

5 Environmental Characteristics

- 5-1 Overall echo sensitivity shall not change by more than $\pm 3\text{dB}$ in the temperature range of -30°C to 70°C at a relative humidity of $\pm 50\%$
- 5-2 Overall echo sensitivity shall not change by more than $\pm 3\text{dB}$ in the humidity range of 10% to 90% at the temperature of 25°C
- 5-3 Overall echo sensitivity shall be within $\pm 3\text{dB}$ of the specified values after the device is subjected to any or all of the belows
 - 5-3-1 Operation at 90% relative humidity and 40°C for 100 hours, followed by a normalization period of 24 hours at 30% and 25°C
 - 5-3-2 Storage at -40°C to $+80^{\circ}\text{C}$ for 24 hours followed by a normalization period of an hour at 25°C
 - 5-3-3 Vibration at 10 to 55Hz, 1.5mm amplitude. 1 minute sweep. X, Y, Z, 3 each axis for 3 hours.
 - 5-3-4 Shock: After impact of 50G is applied following. X, Y, Z, 3 axis /3 cycle / each direction.

6 Mechanical Characteristics

Lead strength

To pull longitudinally 1.0 kgf min.

To push longitudinally 1.0 kgf min.

7 Warranty

- 7-1 Warranty period is one year after delivery
- 7-2 Defective transducers attributable to manufacturer's responsibility shall be replaced for free, during the warranty period. However, following cases are out of the this replacement.
 - 7-2-1 Unsuitable handling or misuse by user.
 - 7-2-2 Modification or repair by user.
 - 7-2-3 Any other cases not responsible for manufacturer such as natural calamity, accident, etc.

This warranty covers only replacement. Any loss derived from failure or malfunction of the transducer, or cost to replace is excluded from this warranty.

Dimensions: unit mm

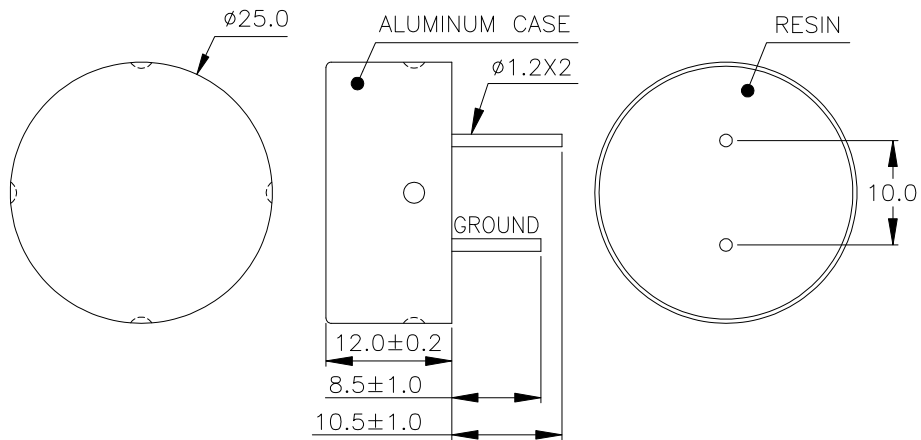

Figure 1

Sound Pressure Level measuring system:

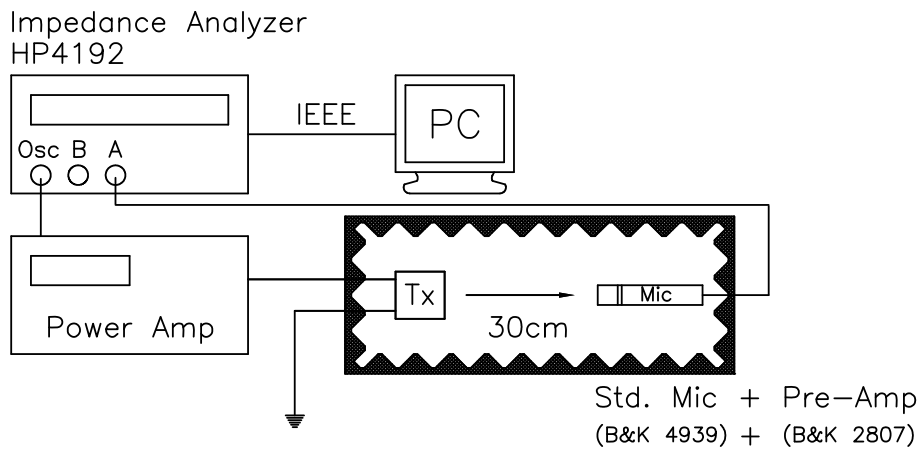

Figure 2

Sensitivity measuring system:

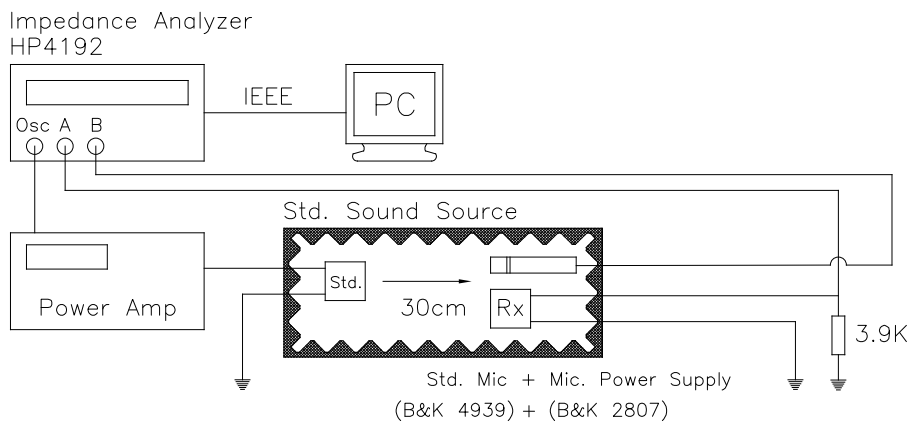

Figure 3