

SMA
NEX10

Adaptor
NEX10 Jack – SMA Plug

32S189-K00N5

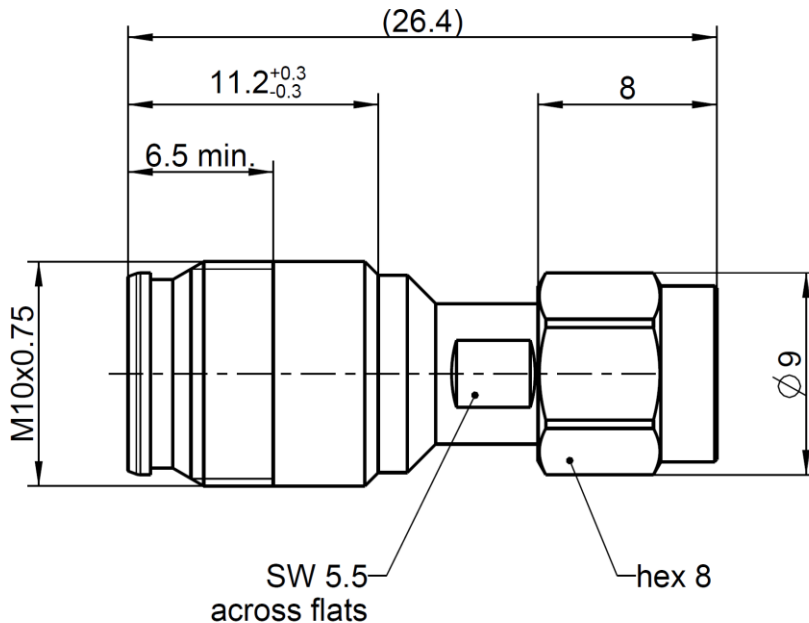

All dimensions are in mm; tolerances according to ISO 2768 m-H

Interface

According to NEX10 side: NEX10®
SMA side: IEC 60169-15, EN 122110, MIL-STD-348A, Fig. 310

Documents

N/A

Material and plating

Connector parts

Center contact SMA side:
Center contact NEX10 side:
Outer contact
Body
Dielectric
Gasket

Material

Brass
CuBe
Brass
Brass
PTFE
Silicone

Plating

AuroDur®, gold plated
AuroDur®, gold plated
White bronze(e.g. Optalloy®)
White bronze(e.g. Optalloy®)

Technical Data Sheet

Rosenberger

SMA
NEX10

Adaptor
NEX10 Jack – SMA Plug

32S189-K00N5

Electrical data

Impedance	50 Ω	
Frequency	DC to 12 GHz	
Return loss	≥ 32 dB @ DC to 4 GHz	
	≥ 30 dB @ 4 GHz to 6 GHz	
	≥ 28 dB @ 6 GHz to 10 GHz	
Insertion loss	≤ 0.05 x √ f [GHz] dB	
Insulation resistance	≥ 5 GΩ	
Center contact resistance	≤ 2.0 mΩ, NEX10 side	≤ 3 mΩ, SMA side
Outer contact resistance	≤ 1.0 mΩ, NEX10 side	≤ 2 mΩ, SMA side
Working voltage	500 V rms	
RF-leakage	≥ 100 dB @ DC to 1 GHz	
Power handling (at 20 °C, sea level, VSWR 1.0)	≤ 200 W @ 2 GHz	

Mechanical data

	NEX10 side	SMA side
Mating cycles	≥ 100	≥ 100
Center contact captivation axial	≥ 25 N	
Recommended torque	1.5 Nm	0.5 Nm

Environmental data

Temperature range	-55 °C to +125 °C operating temperature
Thermal shock	IEC 61169-1 9.4.4
Vibration	IEC 61169-1 9.3.3 and IEC 60068-2-64
Shock	IEC 61169-1 9.3.14
Degree of protection (mated pair)	IEC 60529, IP68 24h / 1m
RoHS	compliant

Tooling

N/A

Suitable cables

N/A

Weight

Weight 9.3 g/pce

While the information has been carefully compiled to the best of our knowledge, nothing is intended as representation or warranty on our part and no statement herein shall be construed as recommendation to infringe existing patents. In the effort to improve our products, we reserve the right to make changes judged to be necessary.

For the installation of the electrotechnical equipment, particular electrotechnical expertise is required.



Draft	Date	Approved	Date	Rev.	Engineering change number	Name	Date
F. Fraunhofer	26.09.17	Chr. Janßen	18.11.20	b00	20-1927	S. Huber-Siegl	18.11.20
Rosenberger Hochfrequenztechnik GmbH & Co. KG P.O.Box 1260 D-84526 Tittmoning Germany www.rosenberger.de						Tel. : +49 8684 18-0 Email : info@rosenberger.de	
						Page 2 / 2	