

TW3972XF

TW3972XF Extended-Filter Triple-Band GNSS Antenna + L-Band

Frequency Coverage: GPS/QZSS-L1/L2/L5, GLONASS-G1/G2/G3, Galileo-E1/E5a/E5b, BeiDou-B1/B2/B2a, NavIC-L5
+L-band correction services

The TW3972XF is a precision-tuned triple-band Accutenna[®] technology antenna providing coverage for triple-band GPS/QZSS-L1/L2/L5, GLONASS-G1/G2/G3, Galileo-E1/E5a/E5b, BeiDou-B1/B2/B2a, NavIC-L5, including the satellite-based augmentation system (SBAS) available in the region of operation [WAAS (North America), EGNOS (Europe), MSAS (Japan), or GAGAN (India)], plus L-Band correction services. It is especially designed for precision triple-frequency positioning.

The radio frequency spectrum has become more congested as new LTE bands are activated and their signals or harmonic frequencies [e.g. 800MHz x 2 = 1600MHz (GLONASS-G1)] can affect GNSS antennas and receivers. In North America, planned Ligado signals at 1525 - 1536 MHz can especially impact GNSS antennas that support space-based L-band correction services (1539 - 1559 MHz). New LTE signals in Europe [Band 32 (1452 - 1496 MHz)] and Japan [Bands 11 and 21 (1476 - 1511 MHz)] have also been observed to interfere with GNSS signals. In addition, Inmarsat satellite communication (uplink: 1626.5 - 1660.5 MHz) can also affect GNSS signals. The new Tallysman XF antennas have been designed to mitigate out-of-band signals and prevent GNSS antenna saturation. Tallysman's custom XF filtering mitigates all existing signals and new Ligado and LTE signals, enabling the antennas and attached GNSS receivers to perform optimally.

Ideal for train control sensors, autonomous vehicle tracking and guidance, precision agriculture, and other applications where precision matters, The TW3972XF provides superior multipath signal rejection, a linear phase response, and tight phase centre variation (PCV).

The TW3972XF features a precision-tuned, twin circular dual-feed, stacked patch element. The signals from the two orthogonal feeds are combined in a hybrid combiner, amplified in a wideband LNA, then band-split for narrow filtering in each band and further amplified prior to recombination at the output. The antenna also has a strong pre-filter to mitigate inter-modulated signal interference from Ligado, LTE and other cellular bands. The TW3972XF offers excellent axial ratio and a tightly grouped phase centre variation.

The TW3972XF meets all requirements of the Association of American Railroads' Electronics Environmental Requirements and System Management Standard (S-9401.V1.0). In addition, it is also compliant with the EN45545-2, EN50121, EN50155, and EN61373 standards.

The TW3972XF is housed in a through-hole mount, weatherproof enclosure for permanent installations. L-bracket (PN 23-0040-0) or pipe mount (PN 23-0065-0) are available. A 100-mm ground plane is recommended for all installations. This antenna is also available in an OEM format: TW3967XF (28 dB) and TW3972EXF (37 dB).



Applications

- Autonomous vehicle tracking and guidance
- Positive Train Control (PTC)
- Positive Train Location (PTL)
- Precision GNSS position
- Precision agriculture
- Triple-frequency RTK and PPP receivers
- Safety & security

Features

- Very low noise preamp (< 2.5 dB typ.)
- Low axial ratio (< 2.0 dB typ.)
- Tight phase centre variation
- High-gain LNA (37 dB typ.)
- Low current (45 mA typ.)
- ESD circuit protection (15 kV)
- Invariant performance from 2.5 to 16 VDC
- IP69K, REACH, RoHS, and S-9401.V1.0 compliant
- EN45545-2, EN50121, EN50155, and EN61373 compliant

Benefits

- Excellent interference mitigation
- Excellent multipath rejection
- Increased system accuracy
- Excellent signal-to-noise ratio

About Tallysman: With global headquarters and manufacturing in Ottawa, Canada, Tallysman is a leading manufacturer of high-precision antennas and components for Global Navigation Satellite System (GNSS) applications. Tallysman's mission is to support the needs of a new generation of positioning systems by delivering unprecedented antenna precision at competitive prices. Learn more at www.tallysman.com

Revision: 1.6

Contact us:
info@tallysman.com
T: +1 613 591-3131

TW3972XF Extended-Filter Triple-Band GNSS Antenna + L-Band

Frequency Coverage:

GPS/QZSS-L1/L2/L5, GLONASS-G1/G2/G3, Galileo-E1/E5a/E5b, BeiDou-B1/B2/B2a, NavIC-L5
+L-band correction services

Antenna

Technology Dual-feed Stacked RHCP ceramic patch

		Gain	Axial Ratio
		dBic typ. at Zenith	dB at Zenith
GNSS			
GPS / QZSS	L1	4.0	< 1.0
	L2	4.0	< 1.0
	L5	-1.5	< 1.5
GLONASS	G1	2.5	< 1.5
	G2	2.5	< 1.5
	G3	2.5	< 1.5
Galileo	E1	4.0	< 1.0
	E5a	-1.5	< 1.5
	E5b	2.5	< 1.5
	E6	-	-
BeiDou	B1	4.0	< 1.0
	B2	2.5	< 1.5
	B2a	-1.5	< 1.5
	B3	-	-
IRNSS / NavIC	L5	-1.5	< 1.5
QZSS	L6	-	-
L-band correction services		3.5	< 1.0
Satellite Communications			
Iridium		-	-
Globalstar		-	-
Other			
Axial Ratio at 10°	-	Efficiency	-
Phase Centre Variation	± 10 mm		

Mechanicals

Mechanical Size	66 mm (dia.) x 21 mm (h.) [100 mm ground plane recommended]
Weight	185 g
Available Connectors	see Ordering Guide
Radome / Enclosure	Radome: EXL9330, Base: Zamak White Metal
Mount	Through-hole

Environmental

Operating Temperature	-70 °C to 85 °C
Storage Temperature	-70 °C to 95 °C
Mechanical Vibration	MIL-STD-810D Method 514.4 and 514.5
Shock and Drop	MIL-STD-810G Method 516.6
Salt Fog	MIL-STD-810F Method 509.4
Low Pressure - Altitude	-
IP Rating (housing)	IP69K
Compliance	IPC-A-610, FCC, RED / CE Mark, RoHS, REACH, S-9401.V1.0, EN45545-2, EN50121, EN50155, EN61373

Warranty:

Parts and Labour **3-year standard warranty**

Low Noise Amplifier (LNA) - Measured at 3.0 VDC and 25°C

Frequency Bandwidth	Out-of-Band Rejection
Lower Band	1160 - 1255 MHz ≥ 70 dB @ ≤ 1050 MHz ≥ 65 dB @ ≤ 1125 MHz ≥ 70 dB @ ≥ 1350 MHz
L-band corrections services	1539 - 1559 MHz ≥ 65 dB @ ≤ 1500 MHz ≥ 45 dB @ ≤ 1525 MHz ≥ 30 dB @ ≥ 1626 MHz ≥ 65 dB @ ≥ 1650 MHz
Upper Band	1559 - 1606 MHz ≥ 65 dB @ ≤ 1500 MHz ≥ 45 dB @ ≤ 1525 MHz ≥ 30 dB @ ≥ 1626 MHz ≥ 65 dB @ ≥ 1650 MHz

Architecture	Pre-filter → LNA stage 1 → filter → LNA stage 2
Gain	37 dB typ. 35 dB min.
Noise Figure	2.5 dB typ. @ 25 °C
VSWR	< 1.5:1 typ. 1.8:1 max.
Supply Voltage Range	2.5 to 16 VDC nominal, up to 50mV p-p ripple
Supply Current	45 mA typ. @ 25 °C
ESD Circuit Protection	15 kV air discharge
P 1dB Output	5.5 dBm typ.
Group Delay Variation	12 ns @ (L1+G1) 7 ns @ (L5+L2+G2)
Group Delay	

Mechanical Diagram

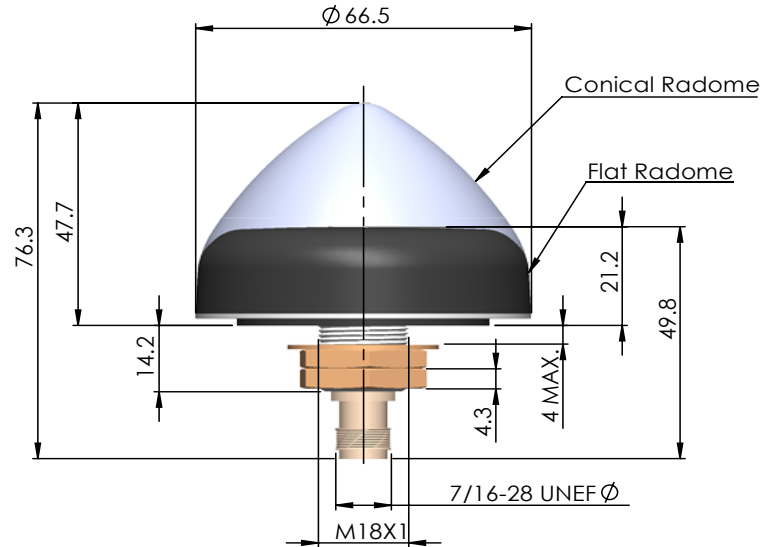

Ordering Information

Part Number **33-3972XF-xx-yy-zzzz**

where xx = connector type, yy = shape and colour of radome, and zzzz = cable length in mm

Please refer to our **Ordering Guide** to review available radomes and connectors at:
<https://www.tallysman.com/resource/tallysman-ordering-guide/>