

SYMBOL DEFINITION				TOTAL NO OF INSPECTIONS REQUIRED	
□	A DIMENSION WITHOUT AN INSPECTION REPORT SYMBOL DOES NOT REQUIRE INSPECTION. IT MAY BE CONTROLLED ON THE INDIVIDUAL COMPONENT DRAWING.	12	10		
				LAST NO. USED	
				10	

DATE	STG	REV	N/P	CHG	ZONE	REVISION HISTORY		AUTH	DR	APV	REV
						NO MISSING SYMBOL NUMBER	NO MISSING SYMBOL NUMBER				
29.JL.05	R	01	-	-	-	15459045 - MOVED TO TAXI; ALL PARTS - RELEASED		270573	AKJ	AKJ	RC
04.N005	R	02	-	-	-	ALL PARTS - ADDED TYPE 101		273978	MM	MM	RC
12.JL.06	R	03	-	-	-	ALL PARTS - UPDATED PDM ATTRIBUTES		282292	MM	MM	RC
28A0U6	R	04	-	-	-	15429045 - ADDED 13549070 RESISTOR & REMOVED 15455931 TERM/RESISTOR ASM 13534887 - RESISTOR WAS 13534629; 13534888 - RESISTOR WAS 13534630; 13534889 - RESISTOR WAS 13534631; 13534890 - RESISTOR WAS 13534632; 13534891 - RESISTOR WAS 13534633; 13534892 - RESISTOR WAS 13534634; 13534893 - RESISTOR WAS 13534635; 13534894 - RESISTOR WAS 13534636; 13534895 - RESISTOR WAS 13534637; ALL PARTS - REMOVED TERM/RESISTOR ASM HEADER FROM THE CHART		283575	EES	EES	GR
20SE06	R	05	-	-	-	ALL PARTS - UPDATED PDM ATTRIBUTES		284867	JTZ	FRG	REB
11.N07	R	06	-	-	-	ALL PARTS - REVISED TERMINAL GRAPHICS TO LATEST REVISION		401644	RH	RH	GR
10SE08	R	07	-	-	-	ALL PARTS - ADDED SLEEVE 13662530 TO ASM		405877	JS	JS	KDM
17SE10	R	08	-	-	-	ALL PARTS - SLEEVE P/N 13816192 WAS 13662530		411972	AGM	JVM	JCO
27MY11	R	09	-	-	-	13853078 & 13853079 - RELEASED		414404	FPE	ROC	FPE
20.JL.11	R	10	-	-	-	ALL PARTS - SLEEVE WAS 13816192		414858	HRS	HRS	VMR
29.JL.11	R	11	-	-	-	ALL PARTS - SLEEVE WAS 13662530		414977	HRS	HRS	OAF
24OC11	R	12	-	-	-	13923432 & 13924569 - RELEASED		415734	AJP	JAA	DAB
07NO11	R	13	-	-	-	13923432 - REVISED		416077	DAB	PTB	DAB
03FE12	R	14	-	-	-	13924569 - REVISED		416975	EQH	EQH	EQH
22.JA.13	R	15	-	-	-	15510071 - RELEASED; 13923432 & 13853078 - UPDATED PART AVAILABILITY		421178	JTV	JTV	EDA
28MR13	R	16	-	-	-	15510071 - UPDATED PART AVAILABILITY		421939	EDA	EDA	EDA
09SE14	R	17	-	-	-	33183322, 33183323 - RELEASED		427519	AHG	MEA	MEA
03SE15	R	18	-	-	-	33284011 - RELEASED 13924569 - WAS TYPE 103		430755	AHY	AHY	JFF
03AP18	R	19	-	-	-	35199153 - RELEASED		439413	GDH	JAA	LMV
19.NI18	R	20	-	-	-	35199153 - UPDATED PART AVAILABILITY		440190	JGO	JAA	LMV
21MY19	R	21	-	-	-	35351504 - RELEASED		443326	AHG	AHG	DS

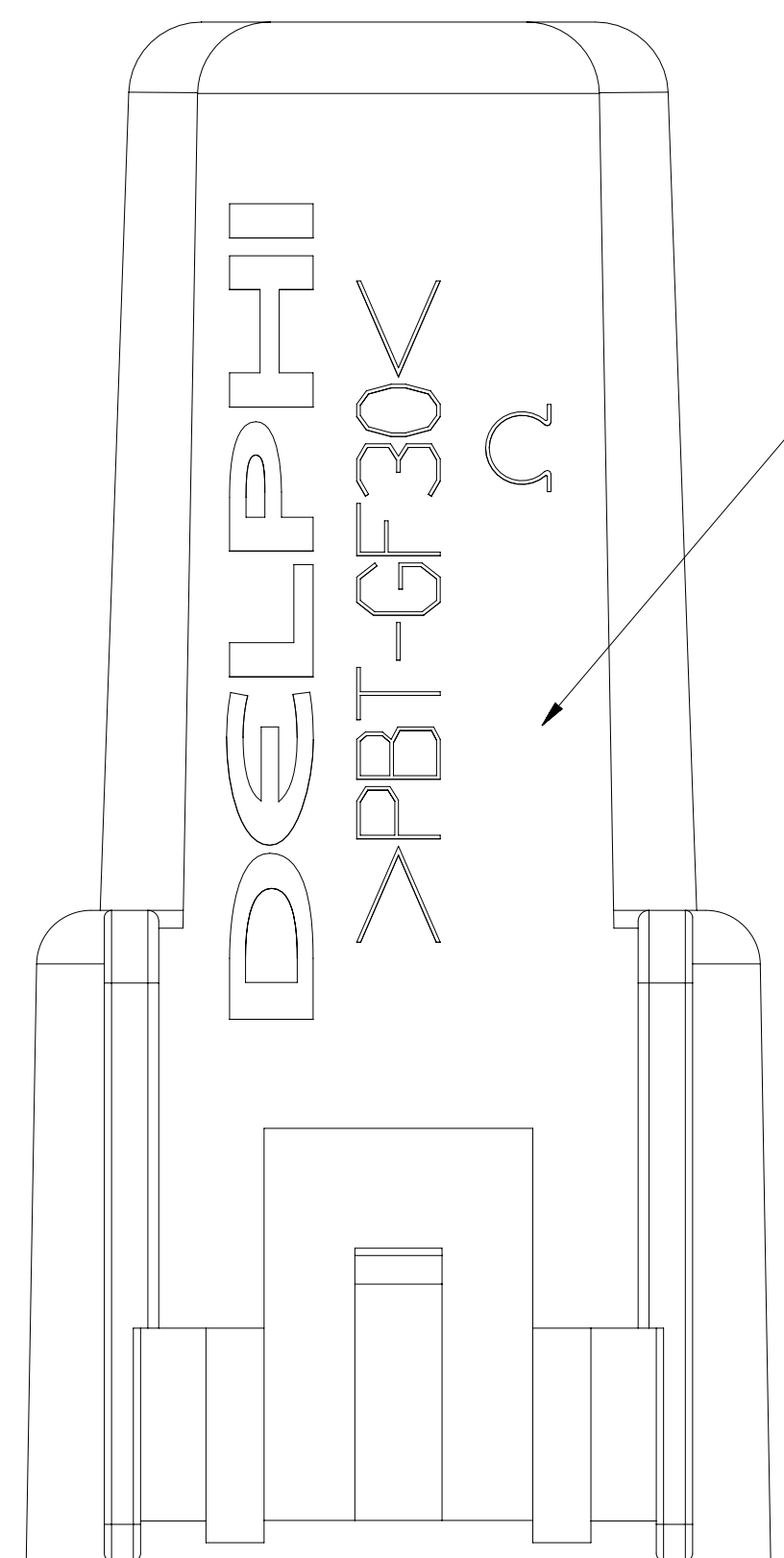

THIS AREA TO BE FREE FOR OHMS RESISTANCE VALUE

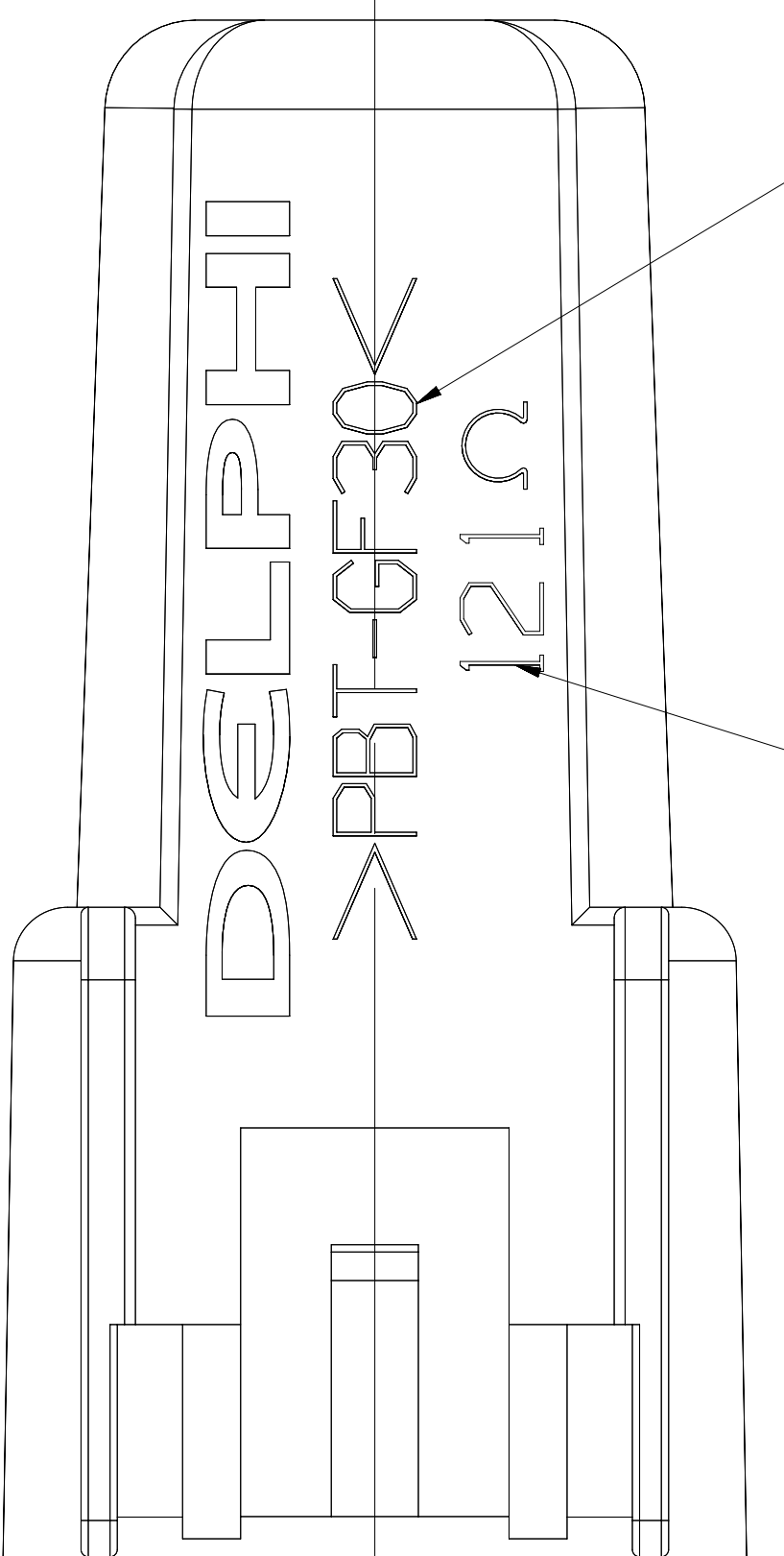

MATERIAL RECYCLING CODE OPTIONAL

SEE CHART FOR RESISTANCE VALUE

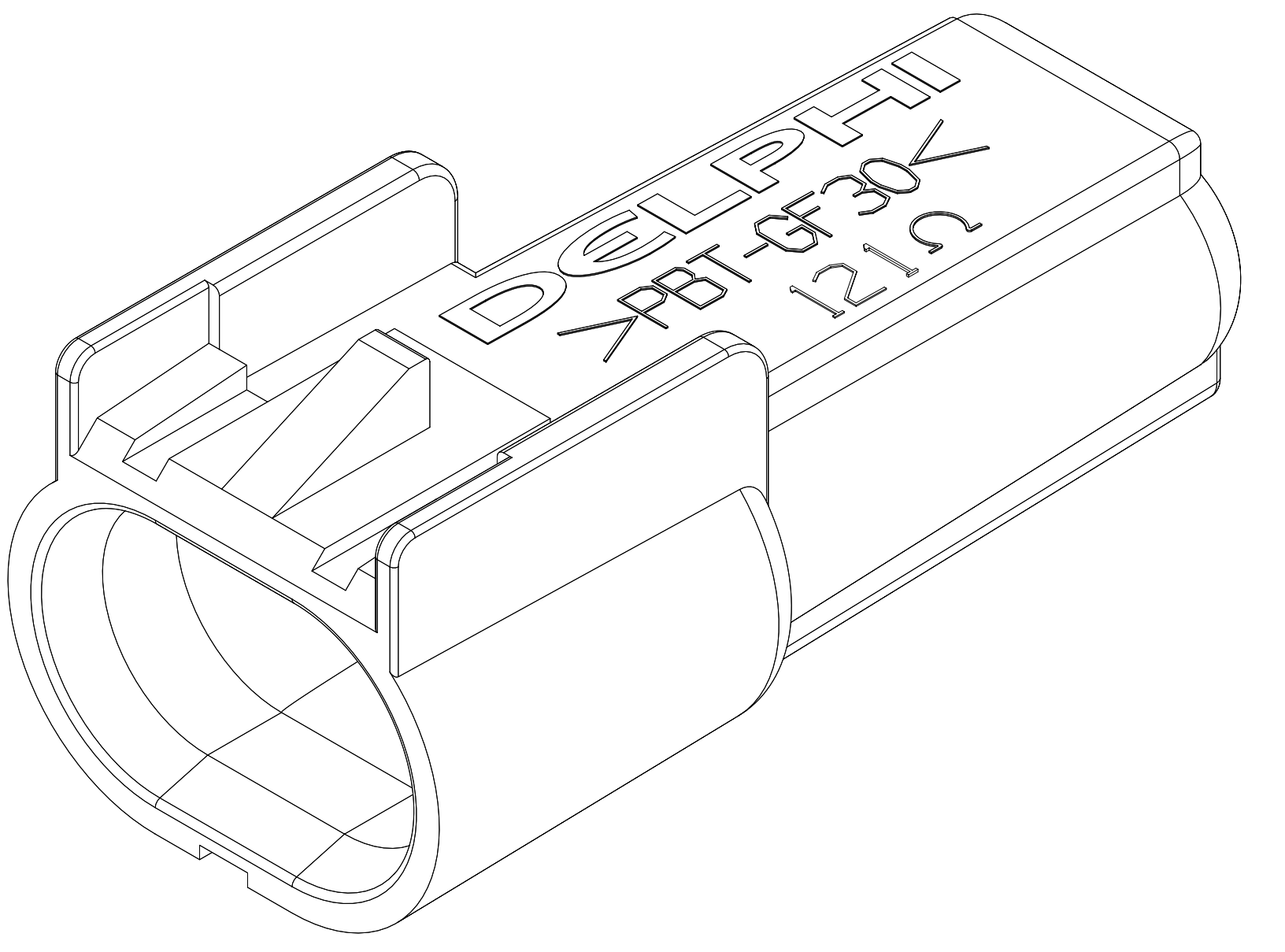

TYPE 102  
SAME AS TYPE 101 EXCEPT AS SHOWN

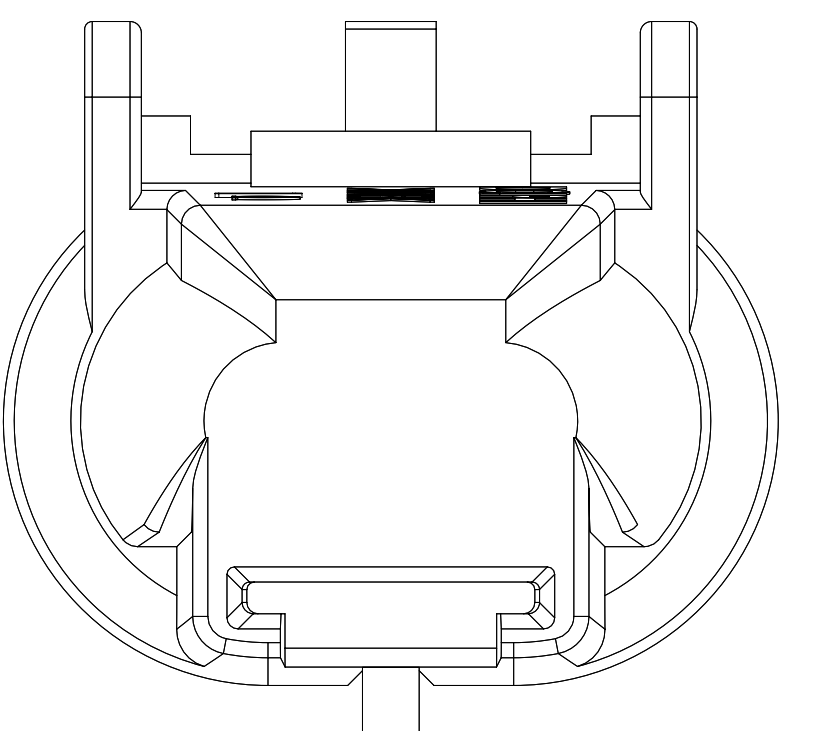
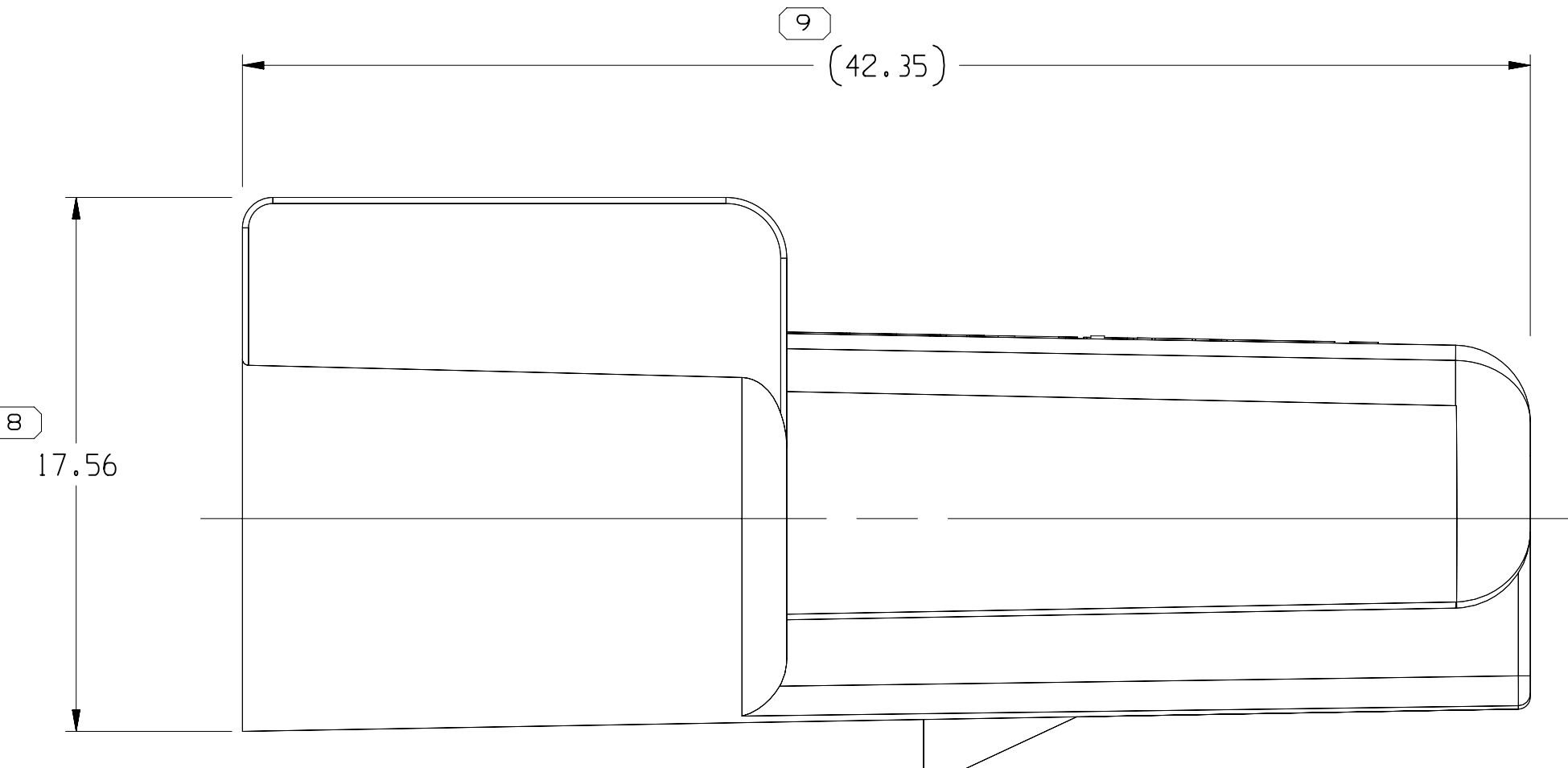
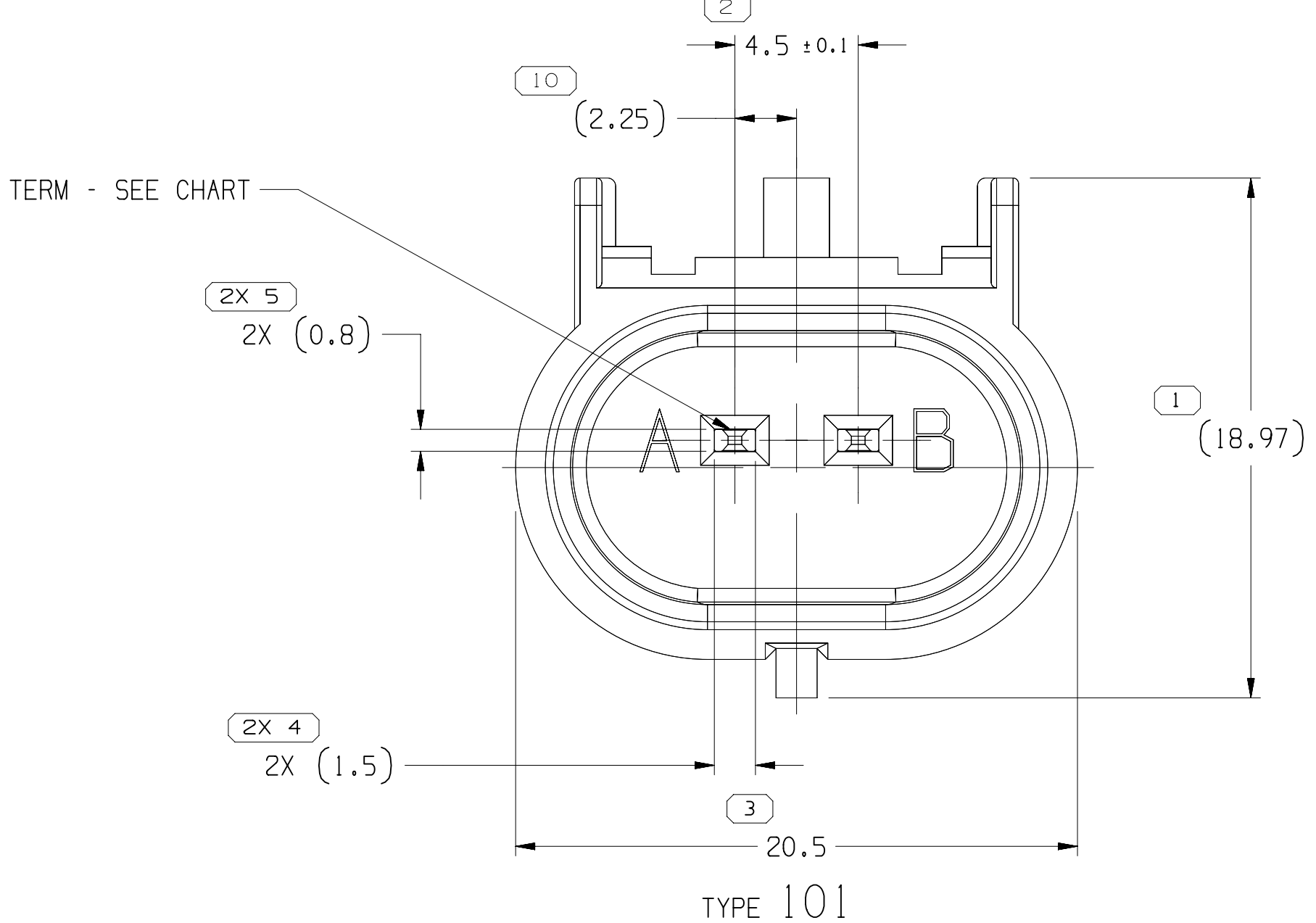

NOTES

- UNLESS OTHERWISE SPECIFIED AND/OR INDICATED:  
DIMENSIONS ARE TO FACE OF VIEW SHOWN AND AUTOMATICALLY ROUNDED BY COMPUTER FOR INSPECTION. (SEE MATH MODEL FOR PRECISE DIMENSIONS.) FOR ALL OTHER DIMENSIONS NOT SHOWN BUT REQUIRED FOR TOOL BUILD, SEE MATH MODEL FOR PRECISE TOOL PATH DATA.
- REFERENCE MATING COMPONENTS OR EQUIVALENT:  
CONNECTOR 13510085  
TERMINAL 15326426. FEMALE TERMINAL MUST HAVE GOLD PLATED TERMINAL CONTACT AREA.
- MATERIAL RECYCLING CODE PER ISO 11469. (2.31X10.11) CHARACTERS AS SHOWN TO BE LOCATED ON ANY EXTERIOR SURFACE.
- CORPORATE BRAND TO BE APPLIED TO PRODUCT DESIGN PER THE LATEST REVISION OF ESD S1085201.
- THIS PRODUCT IS NOT CATEGORIZED AS AN APPEARANCE ITEM, MINOR IMPERFECTIONS INCLUDING, BUT NOT LIMITED TO, FLOW MARKS, COLOR BLEMISHES, GATE VESTIGES, AND SOFT FLASH THAT DO NOT AFFECT THE FIT, FORM, OR FUNCTION OF THE PART ARE PERMISSIBLE PER DMP-4.7-C5-01.

PART NO	REV	N/P	TYPE	TERMINAL	RESISTOR	SLEEVE (2 PLCS)	RESISTANCE VALUE (OHMS ± 1%)	RESISTANCE VALUE (OHMS ± 5%)	MATERIAL SPECIFICATION AND COLOR	VOLUME CM <sup>3</sup>
35351504	01	-	102	15455930	13589068	13816192	7320	-	POLYESTER COMPOUND GRAY	6.182
35199153	01	AA	102	15455930	35199148	13816192	499	-	POLYESTER COMPOUND BLACK	6.182
33284011	01	-	102	15455930	33277834	13816192	39	-	POLYESTER COMPOUND GRAY	6.182
33183323	01	AA	102	15455930	33183321	13816192	-	1200	POLYESTER COMPOUND BLACK	5.859
33183322	01	AA	102	15455930	33183320	13816192	-	2700	POLYESTER COMPOUND BLACK	5.859
15510071	01	AB	102	15455930	15510135	13816192	2700	-	POLYESTER COMPOUND BLACK	5.859
13924569	01	AC	102	15455930	13921531	13816192	18	-	POLYESTER COMPOUND BLACK	5.859
13923432	02	AB	102	15455930	13923431	13816192	8	-	POLYESTER COMPOUND BLACK	5.859
13853079	01	AC	102	15455930	13853076	13816192	39	-	POLYESTER COMPOUND GRAY	5.859
13853078	01	AD	102	15455930	13853075	13816192	3,000	-	POLYESTER COMPOUND BLUE	5.859
13534895	04	AE	102	15455930	13589069	13816192	12,700	-	POLYESTER COMPOUND BLACK	5.859
13534894	04	AE	102	15455930	13589068	13816192	7,320	-	POLYESTER COMPOUND BLACK	5.859
13534893	04	AE	102	15455930	13589067	13816192	3160	-	POLYESTER COMPOUND BLACK	5.859
13534892	04	AE	102	15455930	13589066	13816192	1820	-	POLYESTER COMPOUND BLACK	5.859
13534891	04	AE	102	15455930	13589065	13816192	1150	-	POLYESTER COMPOUND BLACK	5.859
13534890	04	AE	102	15455930	13589064	13816192	715	-	POLYESTER COMPOUND BLACK	5.859
13534889	04	AE	102	15455930	13589063	13816192	453	-	POLYESTER COMPOUND BLACK	5.859
13534888	04	AE	102	15455930	13589062	13816192	255	-	POLYESTER COMPOUND BLACK	5.859
13534887	04	AE	102	15455930	13589061	13816192	115	-	POLYESTER COMPOUND BLACK	5.862
15429045	04	AE	101	15455930	13589070	13816192	121	-	POLYESTER COMPOUND BLACK	5.846

DIMENS (ONAL RANGE (MM))		CHART ET	
FROM	> 0	> 30	> 100
TO	> 20	> 70	> 200
TOLERANCE UNLESS OTHERWISE SPECIFIED		TOLERANCE UNLESS OTHERWISE SPECIFIED	
±0.15   ±0.2   ±0.3   ±0.4   ±0.5   ±0.6   ±0.8   ±1   ±1.2		±1   ±1.2	
ANGULAR TOLERANCE 12°			

**• APTIV •**

CONNECTION SYSTEMS  
WARREN, OH  
COPYRIGHT 2005 APTIV, ALL RIGHTS RESERVED.

THIS DRAWING IS THE PROPERTY OF APTIV AND CONTAINS APTIV CONFIDENTIAL INFORMATION. THE REPRODUCTION, DISTRIBUTION AND UTILIZATION OF THIS DOCUMENT OR ITS RELATED CAD DATA, AS WELL AS COMMUNICATION OF ANY CONTENT TO OTHERS, WITHOUT EXPRESS AUTHORIZATION, IS PROHIBITED.

DR	DATE
ANAND JAGANATHAN	29.JL.05
ANAND JAGANATHAN	29.JL.05
RANDY CVELBAR	29.JL.05
APV/D	
APV/D	
APV/D	
APV/D	
SUBSTANCES OF CONCERN AND RECYCLED CONTENT PER APTIV 10949001	

MATERIAL SPEC CHART

DRAWING NAME:  
TAXI ASM CONN 2 M GT 150 SLD RESISTOR

DRAWING NUMBER:  
**13534897**

SIZE: A0  
SCALE: 3:1  
FRAME NO: 1 OF 1  
SHEET NO: 1 OF 1  
STG: REV: N/P: 1 21

THIRD ANGLE PROJECTION			DO NOT SCALE USE MATH DATA	
ALL DIMENSIONS ARE IN MILLIMETERS		REFERENCE		

13534897\_19 1:13/0514