

Features

- Surface mount and through-hole versions
- 12 mm Square / Dustproof
- One million rotational cycles
- Thin profile
- RoHS compliant*
- AEC-Q200 compliant

Applications

- Volume control on audio equipment
- Motion controllers
- Dishwasher control systems

3382 - 12 mm Rotary Position Sensor

Additional Information

Click these links for more information:



Electrical Characteristics

Standard Resistance Range	2.5K to 100K ohms
Resistance Tolerance	±30 % std.
Independent Linearity ⁽¹⁾	±2 %
Resolution	Essentially infinite
Insulation Resistance @ 500 VDC	100 megohms min.
Dielectric Strength	
Sea Level	500 VAC
70,000 Feet	350 VAC
Adjustment Angle	330 ° nom.

Environmental Characteristics

Power Rating (16 volts max.)	
50 °C	0.05 watt
120 °C	0 watt
Operating Temperature Range	-40 °C to +120 °C
Temperature Coefficient	±500 ppm/°C
Humidity	TRS ±20 %
Shock	20 G TRS ±10 %; VRS ±10 %
Load Life @ 50 °C Rated Power	TRS +10/-20 %
Rotational Life	1,000,000 cycles TRS ±20 %
Thermal Shock	5 cycles TRS ±20 %; VRS ±10 %
Moisture Sensitivity Level	1
ESD Classification (HBM)	N/A

Physical Characteristics

Mechanical Angle	Continuous rotation
Torque	30 gf-cm max.
Weight	Approximately 0.0321 g
Marking	Resistance code and date code
Standard Packaging	
G Style	1000 pcs./13" reel
H Style	50 pcs./tube
IP Rating	IP40

(1) See Independent Linearity, page 3.

Product Dimensions

3382G

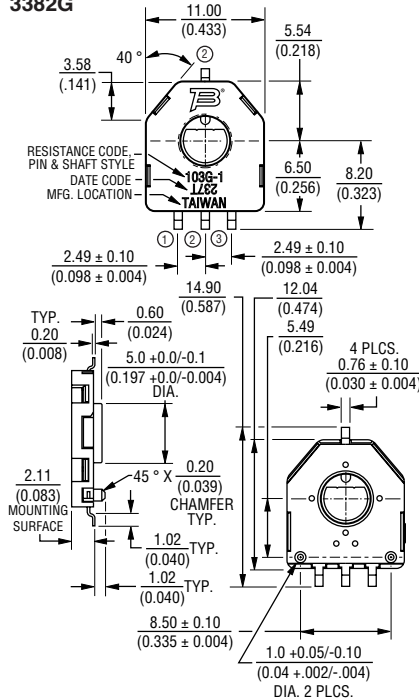

Recommended Land Pattern

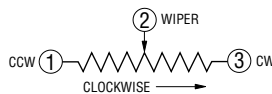
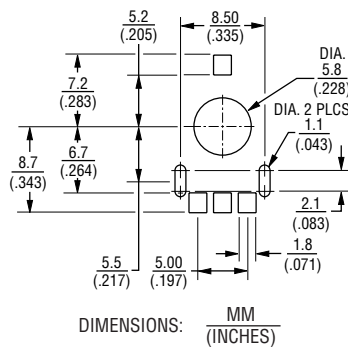

3382H

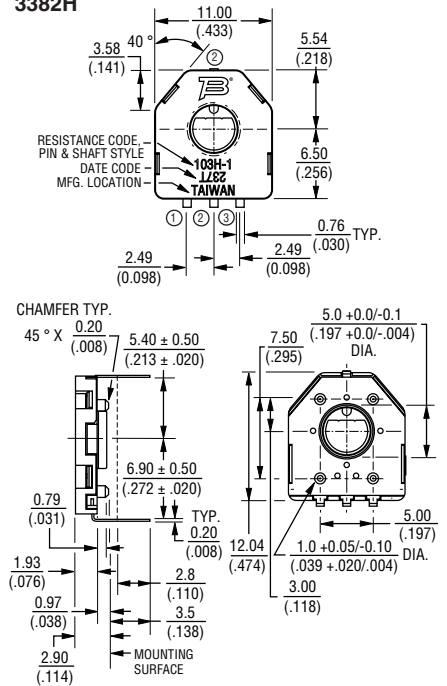

Recommended Land Patterns

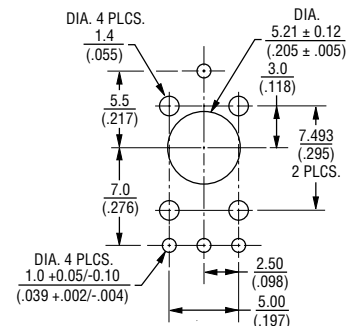
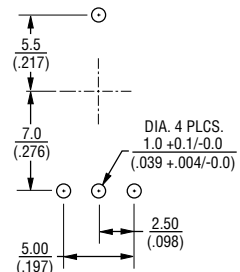

TOLERANCES: ±0.30 UNLESS OTHERWISE NOTED
±(0.12)



WARNING Cancer and Reproductive Harm - www.P65Warnings.ca.gov

*RoHS Directive 2015/863, Mar 31, 2015 and Annex.

Specifications are subject to change without notice.

Users should verify actual device performance in their specific applications.

The products described herein and this document are subject to specific legal disclaimers as set forth on the last page of this document, and at www.bourns.com/docs/legal/disclaimer.pdf.

3382 - 12 mm Rotary Position Sensor

BOURNS®

Rotor Dimensions

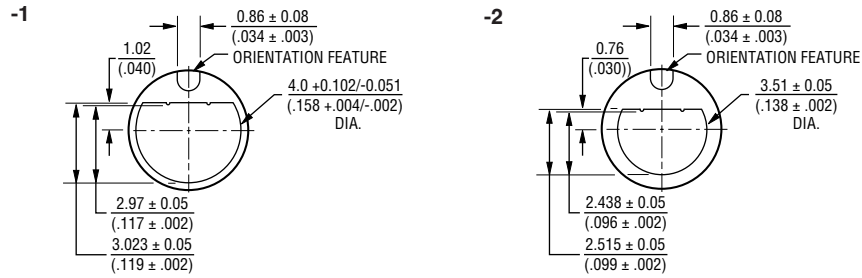

Processing Information

Process Description	Materials	Temperature	Time Interval
1. Apply solder paste to test board (8 - 10 mil thick)	<ul style="list-style-type: none"> Sn/Ag/Cu Alloy water soluble or no clean solder paste Single sided epoxy glass (G10) (UL approved) PC board approx. 4x4x.06 in. 	Room temperature	
2. Place test units onto board	6 units/board		
3. Ramp up	Convection oven		$2.5 \text{ }^\circ\text{C} \pm 0.5 \text{ }^\circ\text{/second}$
4. Preheat		$150 \text{ }^\circ\text{C}$ to $190 \text{ }^\circ\text{C}$	90 ± 30 seconds
5. Time above liquidus		$220 \text{ }^\circ\text{C}$	60-90 seconds
6. Peak temperature			$260 \text{ }^\circ\text{C} +0 \text{ }^\circ\text{-}5 \text{ }^\circ$ 10-20 sec. within $5 \text{ }^\circ\text{C}$ of peak
7. Ramp down		Room temperature	$3 \text{ }^\circ\text{C} \pm 0.5 \text{ }^\circ\text{C/second}$

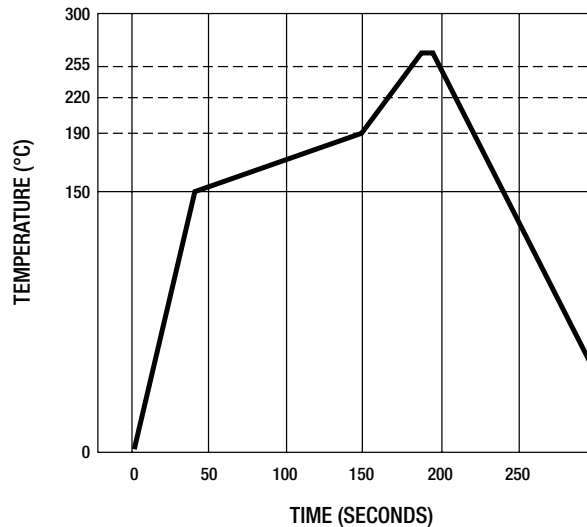

Specifications are subject to change without notice.

Users should verify actual device performance in their specific applications.

The products described herein and this document are subject to specific legal disclaimers as set forth on the last page of this document, and at www.bourns.com/docs/legal/disclaimer.pdf.

3382 - 12 mm Rotary Position Sensor

BOURNS®

Independent Linearity

Independent linearity is the maximum permissible deviation of the actual output curve from a reference line. The slope and position of this reference line are chosen to minimize deviations over all or a portion of the actual electrical travel. The reference line is placed for best straight-line fit through the actual output curve. Please reference the illustration below.

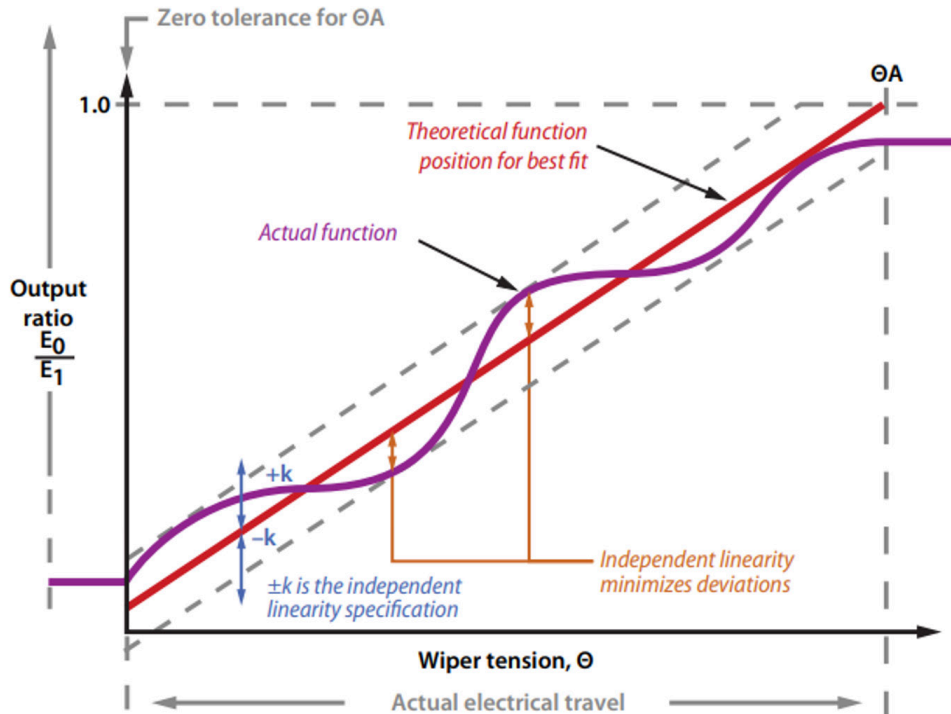

How To Order

Model _____ **3382 G - 1 - 103 G**

Style _____
 G = SMD with 8.5 mm Locator Pin Spacing
 H = Through-hole with 5 mm x 7.5 mm Locator Pin Spacing

Standard Product Indicator _____
 -1 = 4 mm Shaft Diameter
 -2 = 3.5 mm Shaft Diameter

Resistance Code _____

Packaging Designator _____
 G = 1000 pcs./13" Reel (G Style)
 Blank = 50 pcs./Tube (H Style)

Standard Resistance Table

Resistance (Ohms)	Resistance Code
2,500	252
5,000	502
10,000	103
20,000	203
25,000	253
50,000	503
100,000	104

3382 - 12 mm Rotary Position Sensor

BOURNS®

Packaging Specifications

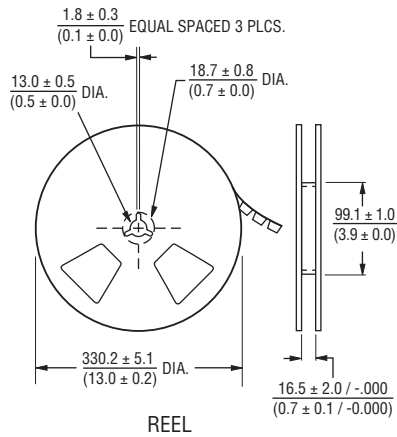
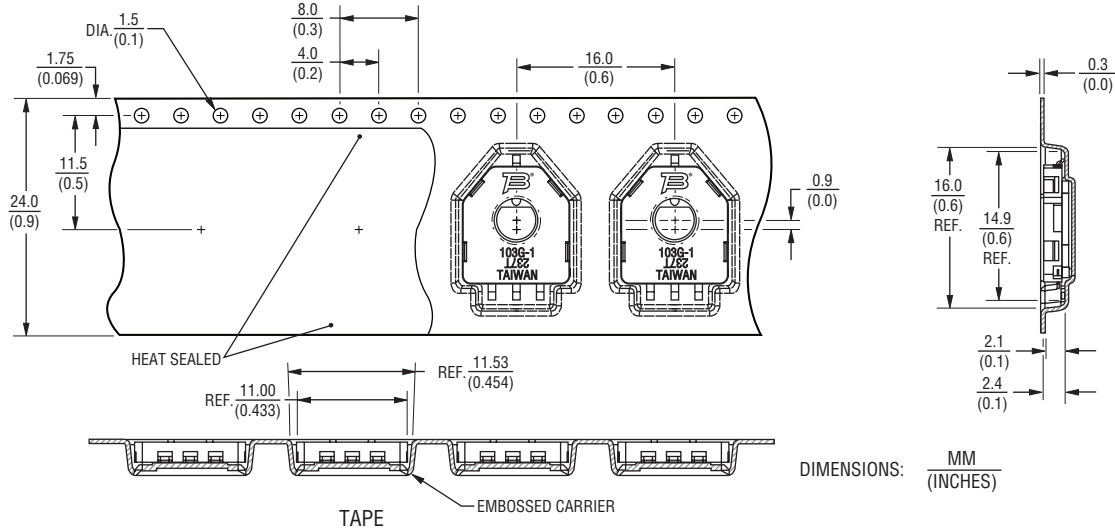

BOURNS®

Asia-Pacific: Tel: +886-2 2562-4117 • Email: asiacus@bourns.com

EMEA: Tel: +36 88 885 877 • Email: eurocus@bourns.com

The Americas: Tel: +1-951 781-5500 • Email: americus@bourns.com

www.bourns.com

REV. 10/23

Specifications are subject to change without notice.

Users should verify actual device performance in their specific applications.

The products described herein and this document are subject to specific legal disclaimers as set forth on the last page of this document, and at www.bourns.com/docs/legal/disclaimer.pdf.