



Features

- Bushing mount
- Optional ± 0.05 linearity option
- Excellent wiper stability
- High stop strength
- Sealable
- RoHS compliant*

3400 - Precision Potentiometer

Electrical Characteristics¹

Standard Resistance Range.....	100 to 500 K ohms
Total Resistance Tolerance.....	$\pm 3\%$
Independent Linearity.....	$\pm 0.15\%$
Effective Electrical Angle.....	$3600^\circ +4^\circ, -0^\circ$
Absolute Minimum Resistance.....	1 ohm or 0.15 % maximum (whichever is greater)
Noise.....	100 ohms ENR maximum
Dielectric Withstanding Voltage.....	MIL-STD-202, Method 301
Sea Level.....	1,000 VAC minimum
80,000 Feet.....	300 VAC minimum
Power Rating (Voltage Limited By Power Dissipation, or 1,000 VAC, Whichever Is Less).....	(40 °C) 5 watts (125 °C) 0 watt
Insulation Resistance (500 VDC).....	1,000 megohms minimum
Resolution.....	See recommended part number

Environmental Characteristics¹

Operating Temperature Range.....	+1 °C to +125 °C
Storage Temperature Range.....	-65 °C to +125 °C
Temperature Coefficient Over Storage Temperature Range ²	± 20 ppm/°C maximum/unit
Vibration.....	10 G
Wiper Bounce.....	0.1 millisecond maximum
Total Resistance Shift.....	$\pm 2\%$ maximum
Voltage Ratio Shift.....	$\pm 0.1\%$ maximum
Shock.....	50 G
Wiper Bounce.....	0.1 millisecond maximum
Total Resistance Shift.....	$\pm 2\%$ maximum
Voltage Ratio Shift.....	$\pm 0.1\%$ maximum
Load Life.....	1,000 hours, 5 watts
Total Resistance Shift.....	$\pm 2\%$ maximum
Rotational Life (No Load).....	2,000,000 shaft revolutions ²
Total Resistance Shift.....	$\pm 5\%$ maximum
Moisture Resistance (MIL-STD-202, Method 103, Condition B)	
Total Resistance Shift.....	$\pm 2\%$ maximum
IP Rating.....	IP 40

Mechanical Characteristics¹

Stop Strength.....	53 N-cm (75 oz.-in.) min.
Mechanical Angle.....	$3600^\circ +4^\circ, -0^\circ$
Torque (Starting & Running).....	0.35 N-cm (0.5 oz.-in.) max.
Mounting.....	170-200 N-cm (15-18 lb.-in.)
Shaft Runout.....	0.08 mm (0.003 in.) T.I.R.
Lateral Runout.....	0.13 mm (0.005 in.) T.I.R.
Shaft End Play.....	0.25 mm (0.010 in.) T.I.R.
Shaft Radial Play.....	0.08 mm (0.003 in.) T.I.R.
Pilot Diameter Runout.....	0.08 mm (0.003 in.) T.I.R.
Backlash.....	1.0 ° maximum
Weight.....	Approximately 114 gm
Terminals.....	Gold-plated solder lugs
Soldering Condition	
Manual Soldering.....	96.5Sn/3.0Ag/0.5Cu solid wire or no-clean rosin cored wire; 370 °C (700 °F) max. for 3 seconds
Wave Soldering.....	96.5Sn/3.0Ag/0.5Cu solder with no-clean flux; 260 °C (500 °F) max. for 5 seconds
Wash processes.....	Not recommended
Marking.....	Manufacturer's name and part number, resistance value and tolerance, linearity tolerance, wiring diagram, and date code.
Ganging (Multiple Section Pots.).....	2 cups maximum
Hardware.....	One lockwasher (H-37-2) and one mounting nut (H-38-2) is shipped with each potentiometer.

- 1 At room ambient: +25 °C nominal and 50 % relative humidity nominal, except as noted.
- 2 Consult manufacturer for complete specification details for resistances below 500 ohms and above 100K ohms.



WARNING Cancer and Reproductive Harm - www.P65Warnings.ca.gov

*RoHS Directive 2015/863, Mar 31, 2015 and Annex.

Specifications are subject to change without notice.

Users should verify actual device performance in their specific applications.

The products described herein and this document are subject to specific legal disclaimers as set forth on the last page of this document, and at www.bourns.com/docs/legal/disclaimer.pdf.

Product Dimensions

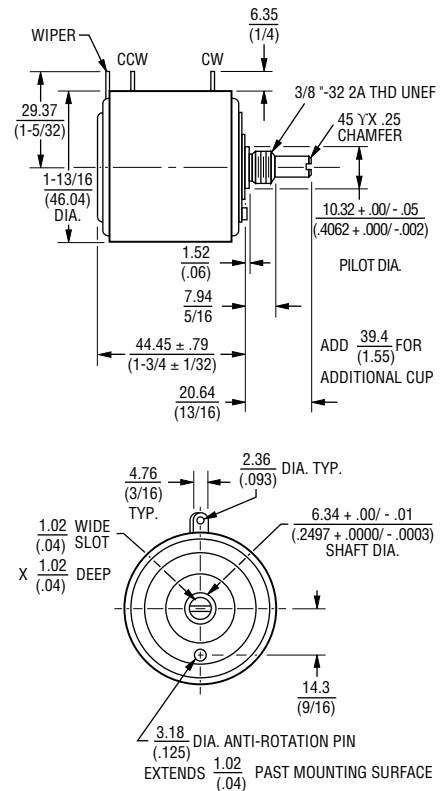

RECOMMENDED PANEL LAYOUT

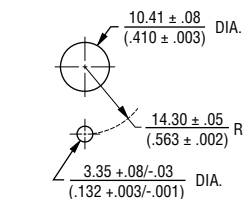

RECOMMENDED PCB THICKNESS: $\frac{2.46}{(0.097)}$
MOUNTING TORQUE: 15-18 LB.-IN.

TOLERANCES: EXCEPT WHERE NOTED

DECIMALS: $XX \pm \frac{.25}{(0.010)}$, $XXX \pm \frac{.13}{(0.005)}$

FRACTIONS: $\pm 1/64$

DIMENSIONS: $\frac{MM}{(IN.)}$

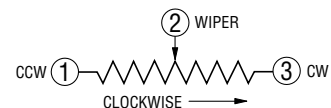

3400 - Precision Potentiometer

BOURNS®

Recommended Part Numbers

Part Number	Resistance (Ω)	Resolution (%)
3400S-1-102L	1,000	.020
3400S-1-502L	5,000	.013
3400S-1-103L	10,000	.010

BOLDFACE LISTINGS ARE IN STOCK AND READILY AVAILABLE THROUGH DISTRIBUTION.

FOR OTHER OPTIONS CONSULT FACTORY.

ROHS IDENTIFIER:
L = COMPLIANT

Panel Thickness Dimensions

(For Bushing Mount Only)

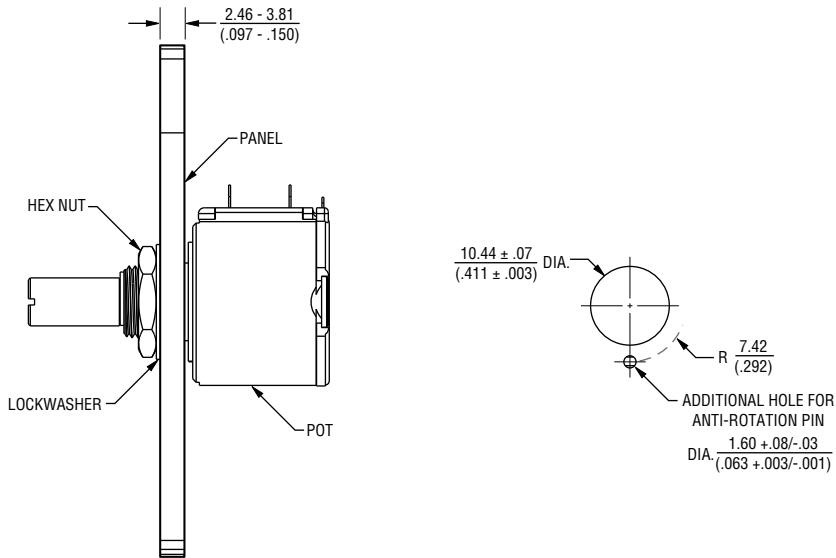

Anti-rotation pin hole is shown at six o'clock position for reference only. The actual location is determined by the customer's application. Refer to the front view of the potentiometer to see the location of the optional A/R pin.

Panel thickness and hole diameters are recommended for best fit. However, customers may adjust the dimensions to suit their specific application.

BOURNS®

Asia-Pacific: Tel: +886-2 2562-4117 • Email: asiacus@bourns.com

EMEA: Tel: +36 88 885 877 • Email: eurocus@bourns.com

The Americas: Tel: +1-951 781-5500 • Email: americus@bourns.com

www.bourns.com

REV. 10/19

Specifications are subject to change without notice.

Users should verify actual device performance in their specific applications.

The products described herein and this document are subject to specific legal disclaimers as set forth on the last page of this document, and at www.bourns.com/docs/legal/disclaimer.pdf.