

THIS DOCUMENT IS THE PROPERTY OF KEYSTONE ELECTRONICS CORP. AND SHALL NOT BE REPRODUCED, DISTRIBUTED OR USED AS A BASIS FOR MANUFACTURE WITHOUT PRIOR WRITTEN PERMISSION FROM KEYSTONE ELECTRONICS CORP.

ACTUAL SIZE

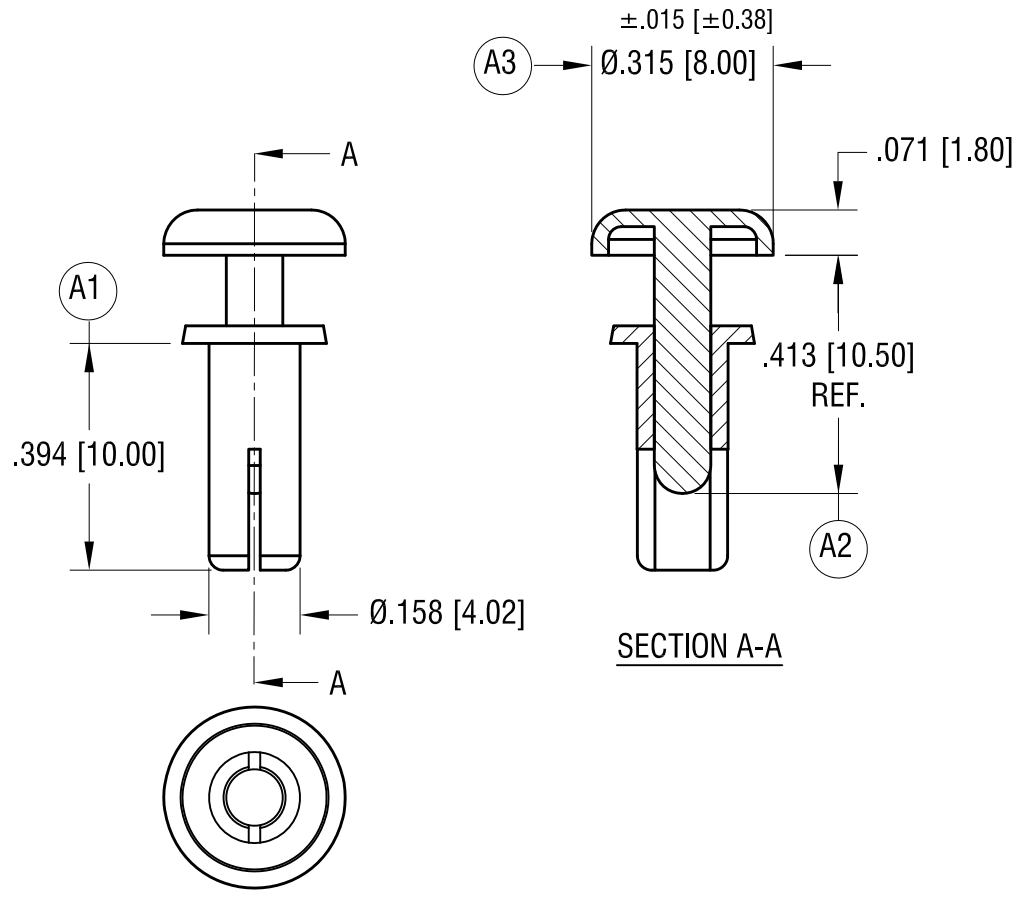
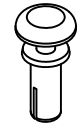

NOTES:

1. RECOMMENDED MOUNTING HOLE:
.163 [4.14] DIA.
2. CHASSIS THICKNESS:
.295 [7.50] TO .335 [8.50]

(A1) WAS .390, (A2) WAS .413 ± .010

(A3) WAS .315 ± .010

8.27.21 CHANGE AS PER ECN 21-099

DATE	DESCRIPTION	REV.
		A

KEYSTONE ELECTRONICS CORP.			
www.keyelco.com • NEW HYDE PARK, NY 11040 • Tel (516) 328-7500			
PART NAME		SNAP RIVET	
MATERIAL			
NYLON 6/6 UL 94V-2 (BLACK COLOR)			
FINISH		DRN BY	DATE
NONE		BOONE	9.29.06
		APP'D	SCALE
		RH	3X
TOLERANCES	INCH [MM]	CODE	DWG NO.
DECIMAL	± .010 [± 0.25]	C	3450
ANGULAR	± 1°		
UNLESS OTHERWISE SPECIFIED			