

*RoHS COMPLIANT



BOURNS®

Features

- Wirewound and Hybritron® elements
- High rotational life
- Optional 0.15 % linearity
- Optional A/R lug
- RoHS compliant*
- Suitable for use under side load
- Designed for HMI and MMI applications
- Dual gang option
- Servo mount option

3548 - 5-Turn Precision Potentiometer

Electrical Characteristics ¹	Wirewound Element	Hybritron® Element
Standard Resistance Range.....	500 to 50K ohms.....	1K to 10K ohms
Total Resistance Tolerance.....	±3 %.....	±10 %
Independent Linearity.....	±0.25 %.....	±0.25 %
Independent Linearity (Maximum Practical).....	±0.15 %.....	±0.15 %
Effective Electrical Angle.....	1800 ° +10 °, -0 °.....	1800 ° +10 °, -0 °
Absolute Minimum Resistance/End Voltage.....	1 ohm or 0.1 % maximum.....	0.4 % maximum
	(whichever is greater)	
Noise/Output Smoothness.....	100 ohms maximum.....	0.15 % maximum
Max. Wiper Current @ 5K ohms.....	20 mA.....	10 mA
Dielectric Withstanding Voltage (MIL-STD-202, Method 301)		
Sea Level.....	1,000 VAC minimum.....	1,000 VAC minimum
Insulation Resistance (500 VDC).....	1,000 megohms minimum.....	1,000 megohms minimum
Resolution.....	See How to Order chart.....	Essentially infinite
Power Rating (Voltage Limited By Power Dissipation)		
+70 °C.....	1.5 watts.....	1.5 watts
+125 °C.....	0 watt.....	0 watt

Environmental Characteristics ¹	Wirewound Element	Hybritron® Element
Operating Temperature Range		
Dynamic.....	-40 °C to +125 °C.....	-40 °C to +125 °C
Static.....	-55 °C to +125 °C.....	-55 °C to +125 °C
Temperature Coefficient (Over Static Temperature Range).....	±50 ppm/°C.....	±100 ppm/°C
Temperature Cycling (5 Cycles Over Static Temperature Range).....	±2 % TR shift max.....	±4 % TR shift max.
Vibration (15 Gs, 10 Hz to 2 kHz)		
Wiper Bounce.....	0.1 ms max.....	0.1 ms max.
Shock (100 Gs, 6 ms sawtooth)		
Wiper Bounce.....	0.1 ms max.....	0.1 ms max.
Load Life (1,000 hours @ 70 °C).....	±2 % TR shift max.....	±5 % TR shift max.
Rotational Life		
No Load.....	1,000,000 shaft revolutions.....	2,500,000 shaft revolutions
Powered (MIL-PRF-12934).....	1,000,000 shaft revolutions.....	2,500,000 shaft revolutions
Moisture Resistance (Mil-Std-202, Method 103).....	±2 % TR shift max.....	±5 % TR shift max.
IP Rating.....	IP 50.....	IP 50

Mechanical Characteristics ¹	Wirewound Element	Hybritron® Element
Mechanical Angle.....		1800 ° +10 °, -0 °
Backlash.....		1.0 ° max.
Stop Strength.....		53 N-cm (75 oz-in.) min.
Torque		
Starting.....		0.5 N-cm (0.7 oz-in.) max.
Running.....		0.5 N-cm (0.7 oz-in.) max.
Clutch.....		1.0 to 4.2 N-cm (1.5 to 6.0 oz-in.)
Mounting.....		170-200 N-cm (15-18 in.-lb.) max.
Shaft Runout T.I.R.....		0.08 mm (0.003 in.)
Lateral Runout T.I.R.....		0.13 mm (0.005 in.)
Shaft End Play T.I.R.....		0.15 mm (0.006 in.)
Pilot Radial Play T.I.R.....		0.08 mm (0.003 in.)
Pilot Diameter Runout T.I.R.....		0.08 mm (0.003 in.)
Weight		
Single.....		19 gm (0.67 oz.) typ.
Dual.....		35 gm. (1.23 oz.) typ.
Shaft Side Load (Max. Allowable)		
Nickel Plated Brass Shaft w/Brass Bushing.....		50 gmf (1.7 ozf)
Stainless Steel Shaft w/Bronze Bushing.....		250 gmf (8.8 ozf)
Terminals.....		Gold-plated solder lugs
Soldering Condition		
Manual Soldering.....	96.5Sn/3.0Ag/0.5Cu solid wire or no-clean rosin cored wire, 370 °C (700 °F) max. for 3 seconds	
Wave Soldering.....	96.5Sn/3.0Ag/0.5Cu solder with no-clean flux, 260 °C (500 °F) max. for 5 seconds	
Wash processes.....		Not recommended
Mounting Hardware.....	One lockwasher and one mounting nut is shipped with each potentiometer	
Recommended Panel Thickness (Bushing Mount).....		2.46-3.81 mm (0.097-0.150 in.)
Marking.....	Manufacturer's symbol, model number, product code and date code	
Standard Packaging.....	Plastic trays (5 pcs./tray)	

¹At room ambient: +25 °C nominal and 50 % relative humidity nominal, except as noted.
For other options, please consult factory.



WARNING
Cancer and Reproductive Harm
www.P65Warnings.ca.gov

*RoHS Directive 2015/863, Mar 31, 2015 and Annex.

Specifications are subject to change without notice. Users should verify actual device performance in their specific applications. The products described herein and this document are subject to specific legal disclaimers as set forth on the last page of this document, and at www.bourns.com/docs/legal/disclaimer.pdf

3548 - 5-Turn Precision Potentiometer

BOURNS®

Product Dimensions

Single Gang, Bushing Mount

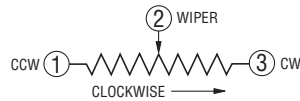
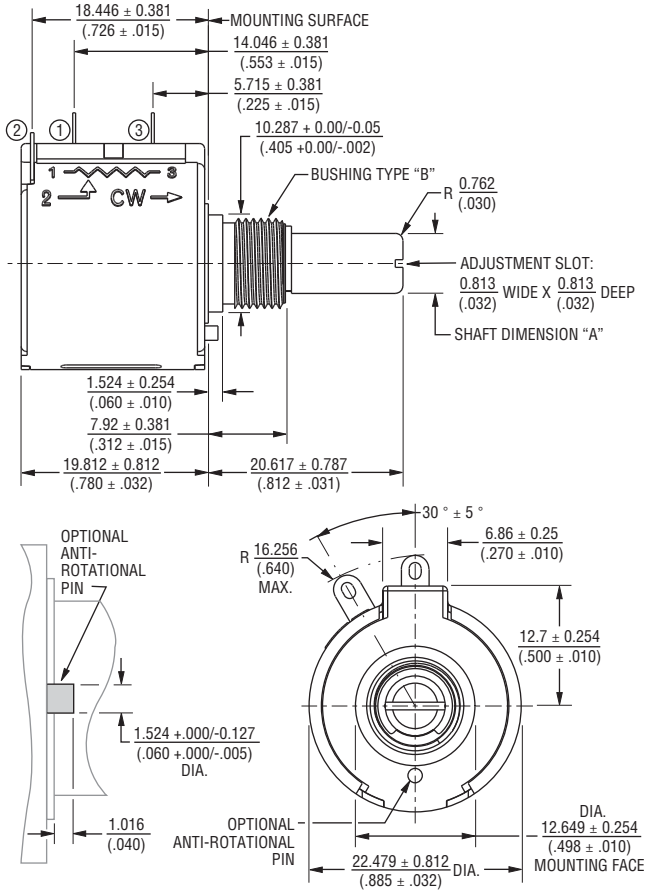

TOLERANCES: EXCEPT WHERE NOTED
 DECIMALS: .XX ± (.02) .XXX ± (.005) .XXXX ± (.0005)
 DIMENSIONS: $\frac{MM}{(IN)}$

Bushing Selection Code	Shaft Dimension "A"	Shaft Material	Bushing Type "B"	Bushing Material
A	6.34 +0/-0.022 (0.2497 +0/-0.0009)	Nickel Plated Brass	3/8" 32-UNEF- 2A THD.	Brass
B	6.00 +0/-0.022 (0.2362 +0/-0.0009)	Nickel Plated Brass	M9 X 0.75-8g	Brass
C	6.34 +0/-0.007 (0.2497 +0/-0.0003)	Stainless Steel	3/8" 32-UNEF- 2A THD.	Bronze
D	6.00 +0/-0.007 (0.2362 +0/-0.0003)	Stainless Steel	M9 X 0.75-8g	Bronze
G	6.34 +0/-0.007 (0.2497 +0/-0.0003)	Stainless Steel	3/8" 32-UNEF- 2A THD.	Bronze
H	6.00 +0/-0.007 (0.2362 +0/-0.0003)	Stainless Steel	M9 X 0.75-8g	Bronze

Dual Gang, Bushing Mount

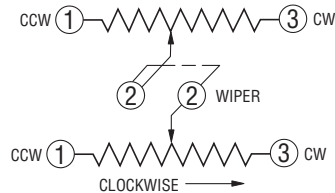
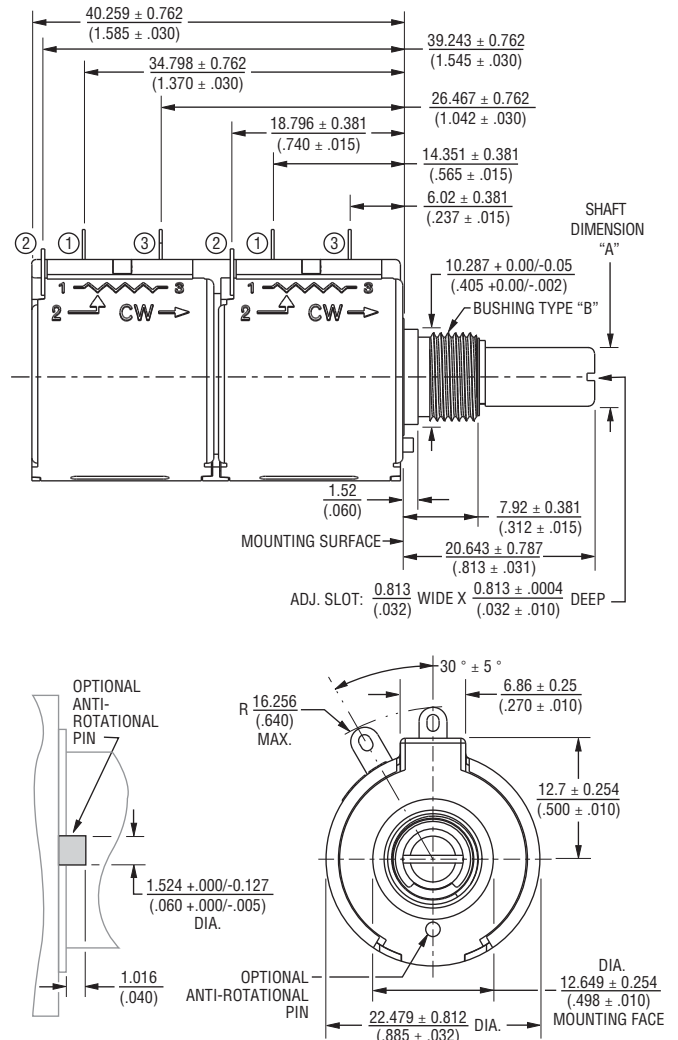

Specifications are subject to change without notice.
 Users should verify actual device performance in their specific applications.
 The products described herein and this document are subject to specific legal disclaimers as set forth on the last page of this document, and at www.bourns.com/docs/legal/disclaimer.pdf.

3548 - 5-Turn Precision Potentiometer

BOURNS®

Product Dimensions

Single Gang, Servo Mount

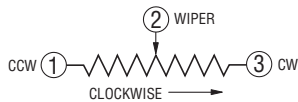
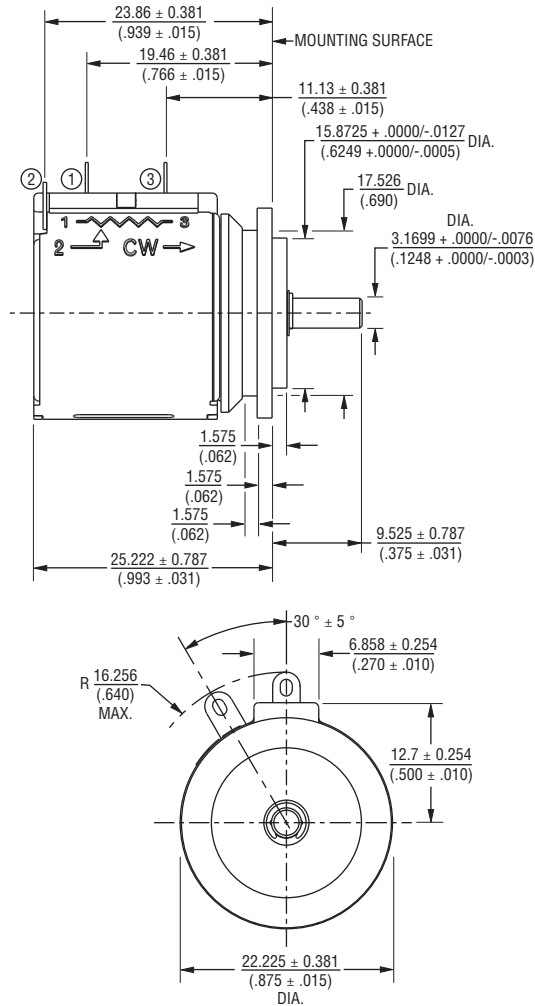

TOLERANCES: EXCEPT WHERE NOTED
 DECIMALS: .XX ± (.02) .XXX ± (.005) .XXXX ± (.0005)
 DIMENSIONS: $\frac{MM}{(IN)}$

Dual Gang, Servo Mount

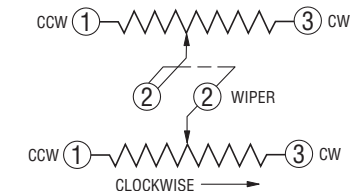
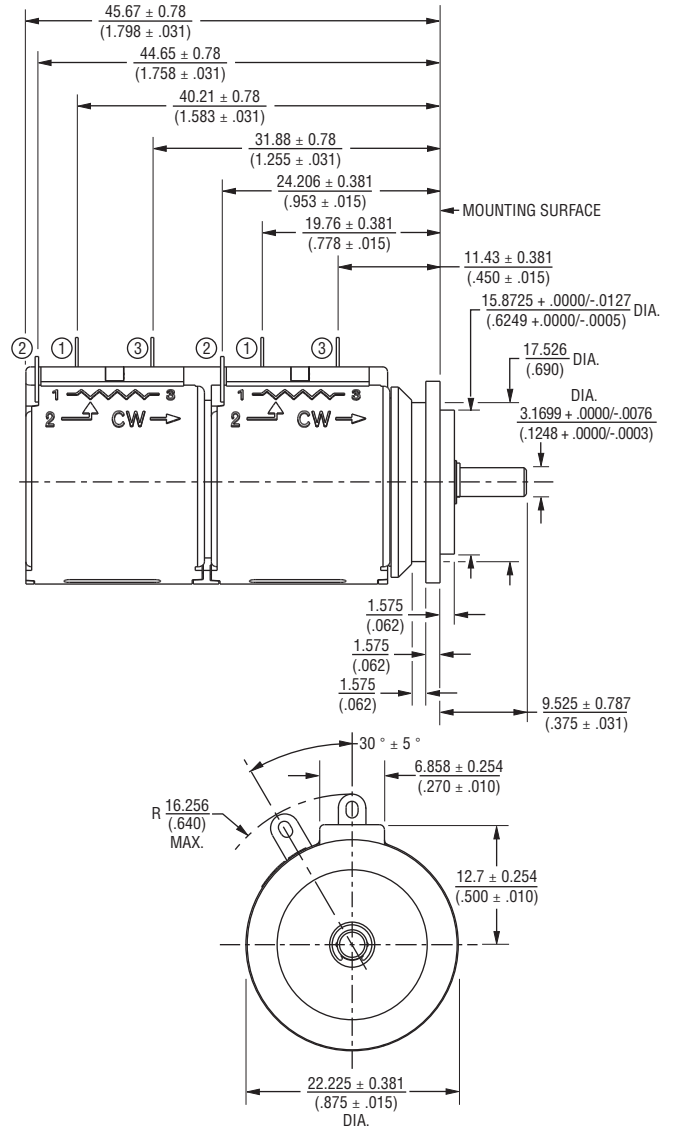

Specifications are subject to change without notice.
 Users should verify actual device performance in their specific applications.
 The products described herein and this document are subject to specific legal
 disclaimers as set forth on the last page of this document, and at
www.bourns.com/docs/legal/disclaimer.pdf.

3548 - 5-Turn Precision Potentiometer

BOURNS®

Panel Thickness Dimensions

(For Bushing Mount Only)

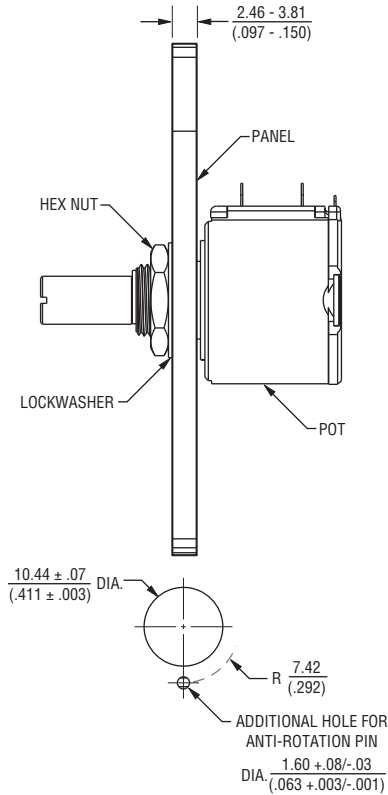

Anti-rotation pin hole is shown at six o'clock position for reference only. The actual location is determined by the customer's application. Refer to the front view of the potentiometer to see the location of the optional A/R pin.

Panel thickness and hole diameters are recommended for best fit. However, customers may adjust the dimensions to suit their specific application.

DIMENSIONS: $\frac{\text{MM}}{\text{(INCHES)}}$ TOLERANCES: $\pm \frac{0.127}{(.005)}$

How To Order

3 5 4 8 S - 2 A A - 1 0 3 / 1 0 3 A

MODEL DESIGNATOR	
Code	Description
3548	5-Turn

ELEMENT TYPE	
Code	Description
H	Hybritron®
S	Wirewound

NO. OF SECTIONS	
Code	Description
1	Single
2	Dual

ANTI-ROTATION LUG	
Code	Description
A	None
B	180°

* Anti-rotation lug is not available for servo mount versions.

INDEPENDENT LINEARITY		
Code	Description	
A	0.25 %	
B	0.15 %	

RESISTANCE**		
Code	Element Type	Resolution (%)
102 (1K ohms)	Hybritron®	—
502 (5K ohms)	Hybritron®	—
103 (10K ohms)	Hybritron®	—
201 (200 ohms)	Wirewound	0.069
501 (500 ohms)	Wirewound	0.054
102 (1K ohms)	Wirewound	0.043
202 (2K ohms)	Wirewound	0.044
502 (5K ohms)	Wirewound	0.038
103 (10K ohms)	Wirewound	0.029
203 (20K ohms)	Wirewound	0.023
503 (50K ohms)	Wirewound	0.017

** For Single gang, use only first three digits.
For Dual gang, use six digits separated by a "/".

BUSHING MOUNT						
Code	Shaft FMS	Shaft Dia.	Shaft Material	Bushing Dia.	Bushing Material	Slip Clutch
A	13/16"	1/4"	Nickel Plated Brass	3/8"	Brass	N/A
B	20.6 mm	6 mm	Nickel Plated Brass	9 mm	Brass	N/A
C	13/16"	1/4"	Stainless Steel	3/8"	Bronze	N/A
D	20.6 mm	6 mm	Stainless Steel	9 mm	Bronze	N/A
G	13/16"	1/4"	Stainless Steel	3/8"	Bronze	Yes***
H	20.6 mm	6 mm	Stainless Steel	9 mm	Bronze	Yes***

SERVO MOUNT			
Code	Shaft FMS	Shaft Dia.	Shaft Material
E	3/8"	1/8"	Stainless Steel

*** Not available in dual gang version.

BOURNS®

Asia-Pacific: Tel: +886-2 2562-4117 • Email: asiacus@bourns.com

EMEA: Tel: +36 88 885 877 • Email: eurocus@bourns.com

The Americas: Tel: +1-951 781-5500 • Email: americus@bourns.com

www.bourns.com

REV. 10/19

"Hybritron" is a registered trademark of Bourns, Inc. Specifications are subject to change without notice.

Users should verify actual device performance in their specific applications.

The products described herein and this document are subject to specific legal disclaimers as set forth on the last page of this document, and at www.bourns.com/docs/legal/disclaimer.pdf.